



WIPPERMANN

Main Catalogue 2015

Industrial Chains, Sprockets and Accessories



Product information

Simplex roller chains according to ISO 606 (European type)10

Duplex roller chains according to ISO 606 (European type)11

Triplex roller chains according to ISO 606 (European type)12

Simplex roller chains according to ISO 606 (American type)13

Duplex roller chains according to ISO 606 (American type)14

Triplex roller chains according to ISO 606 (American type)15

Side bow chains16

Roller chains type series GL (straight plates)17

POM-Clips18

POM-Clips with top surface TPU20

Special heavy duty chains22

Power chains22

Hollow pin chains23

BIATHLON

Roller chains according to ISO 60624

BIATHLON KS

Roller chains according to ISO 60626

TRIATHLON HT

Roller chains according to ISO 60628

TRIATHLON KS

Roller chains according to ISO 60630

MARATHON.....32

Roller chains according to ISO 60634

Roller chains type series GL (straight plates)36

Double pitch roller chains according to ISO 127537

Accumulator chains38

Roller chains stainless steel

MARATHON stainless steel40

Roller chains according to ISO 60640

Simplex roller chains (stainless steel)42

Main dimensions according to ISO 60642

Duplex roller chains (stainless steel)43

Main dimensions according to ISO 60643

Triplex roller chains (stainless steel)44

Main dimensions according to ISO 60644

Simplex roller chains (works-standard) / Agricultural roller chains according to ISO 48745

Double pitch roller chains according to ISO 127546

Bush chains47

Roller chains with attachments

Roller chains with single hole bent attachments48

Roller chains with single hole straight attachments and extended pins49

Roller chains with two-hole bent and straight attachments50

Roller chains (stainless steel) as attachment chains51

Roller chains with single hole attachments and inside thread52

Roller chains with two-hole attachments and inside thread53

Double pitch roller chains with single hole bent attachments54

Double pitch roller chains with single hole straight attachments and extended pins55

Roller chains with extended pins on one side/both sides56

Combination connecting links57

Pusher dog58

Special top plate conveyor chain59

Accumulator chains

Accumulator chains60

Axial profile of sprockets for accumulator chains62

Chain guide for accumulator chains62

AFS-Clips63

ATC chains64

Leaf chains

Leaf chains type series LL according to DIN ISO 434768

Leaf chains according to works-standard69

Leaf chains heavy duty design U according to works-standard69

Leaf chains Plate end links and connecting pins70



Leaf chains type series BL according to DIN ISO 4347	71
according to series LH	71
Inverted tooth chains with bushings (60° flank angle)	72
Inverted tooth (silent) chains	73
Inverted tooth (silent) chains type series HD	74
Inverted tooth (silent) chains type series HP	75
Additional product rang	76
Chain breakers / Chain pullers	77
Sprockets	
Sprockets for roller chains according to ISO 606	78
Sprockets (stainless steel) grade 1.4301, for simplex roller chains	86
Sprockets for accumulator chains	87
Sprockets for hollow pin chains 01650	87
Sprockets with integrated ball bearing	87
Sprockets with lantern gear toothing	88
Plate sprockets for simplex roller chains according to ISO 606	89
Chain couplings	92
Sprockets (made to specifications)	93
Groove sizes	93
Axial profile of sprockets for roller chains	94
Calculation of sprocket diameters	95
Toothing check	95
Values for "n" and cot α	96
Sprockets – PCD d_0 and tip circle diameter d_k	97
for roller chains according to ISO 606 and works-standard	97
Accessories	
ETP bushings for shaft-to-hub connections	100
Automatic chain drive tensioning SPANN-BOX® and SPANN-BOY®	102

Technical information

How to order or enquire about sprockets	106
Mounting of chain drives	107
Faulty mounting	107
Lubrication	108
Various types of steel link chains	112
Advantages of roller chain drives	114
Formulas, designations and units	115
Pre-selection of leaf chains	116
Pre-selection of roller chain drives	118
Power diagram for roller chains according to ISO 606 (European type) / according to DIN ISO 10823	120
Power diagram for roller chains according to ISO 606 (American type) / according to DIN ISO 10823	121
Power diagram for roller chains according to ISO 606 (American type, reinforced) / according to DIN ISO 10823	122
Calculation of chain length X	123
Calculation of shaft distance a	124
Determination of chain length L	125
Worked example	126
Construction of chain drives	127
Chain drive configurations with jockey sprockets	128
Maintenance of chain drives	129
Shortening and extending of roller chains	130
How to order or enquire about roller chains	131
How to order or enquire about special chains	132
Request form chain drives	133
Troubleshooting guide for chain drives	134
Chain numbers	135
Representations/service centre Germany	139
Representations Europe	140
Index	142

This catalogue replaces all previous editions.

Chain types, which are no longer manufactured due to rationalisation, may still be available or may be manufactured again, if a sufficient quantity is ordered. We reserve the right to alter non-standard chains or cease their production without prior notice.

Illustrations merely serve for exemplification and are by no means binding for the final design. Permissible length deviations according to ISO. For dimensions without stated tolerances DIN ISO 2768 c applies. All information subject to errors and alterations. Any liability for misprints excluded.

All rights reserved. No part of this catalogue may be reproduced without prior written permission.



Your success is our motivation – for over 120 years now

Reliability and consistently excellent quality. These are the standards we have been applying in the production of industrial chains and sprockets for over 120 years. Our extensive technological know-how, great innovative strength and long-standing expertise gained in countless projects in a large variety of industries have put us in a position to offer our customers an extremely wide range of reliable standard chains as well as innovative, customized drive solutions.

Our international customers' requirements for industrial chains are becoming more and more complex: high fatigue strength, high-temperature application and freedom from maintenance, to name but a few. Maximum performance and optimum efficiency in increasingly demanding applications are the challenges we are successfully taking up in international competition.

Variety is our standard

We offer a broad range of extremely reliable standard chains and sprockets. Whether roller chains with and without attachments, leaf chains or our extensive offer of various special chains – there is barely a manufacturer with a comparable product variety. What's more, we develop and produce tailor-made chain systems for every application on the basis of our modular product system.

In order to be able to offer the perfect drive, conveyor or hoisting solution, we create individual requirement profiles for our customers' applications. The advantage: this enables us to determine the right solution for almost every industry and any field of application. In doing so, our claim to the entire product range from standard to high end always remains the same – finding the perfect solution for our customers' success in the field of drive technology.

And our definition of service even goes one step further: via WIPPERMANN Direct, we supply our customers with the products from our comprehensive standard range within 48 hours.



Unique materials, special heat treatment and high-quality functional coatings – we develop the perfect chain solution rapidly and economically from a variety of own components.



Innovation is our tradition

120 years of experience in the development and production of chains and sprockets have equipped us with the highest engineering and manufacturing expertise. We are committed to continuously promoting the new and further development of our drive components, among others with regard to optimum fatigue strength, wear resistance and corrosion resistance. Due to the growing demands placed upon the efficiency of drive solutions, the maintenance expense must be steadily reduced. We have identified this trend at an early stage and focused on the development of low-maintenance and maintenance-free chains. For our MARATHON and TRIATHLON chains, the Suedwestfalen Chamber of Industry and Commerce has distinguished us as

qualitative leader for maintenance- and lubricant-free high-performance roller chains with an extremely long lifetime.

And we also preserve the heritage of our company founder, Wilhelm Wippermann: we continue the production of high-quality bike and motorbike components with our Connex by WIPPERMANN range which started in 1893. To this end, we use technologies from the industrial chain segment in a targeted manner and in this vein, have also globally established the Connex traditional brand as a provider of high-performance bike chains. Professional cyclists from all over the world value the reliability of our chains and put their trust in our solutions to meet any challenge.



Company founder
Wilhelm Wippermann sen.
*1858 †1929



Extensive know-how and advice for the perfect solution

Our aim is to provide the optimum solution for all applications. The result: complete sprocket-chain systems with perfectly matching components that provide optimum functionality of our customers' drive systems.

We are constantly looking for the perfect solution for difficult applications – often on the basis of our customers' individual requirement profiles. For the development of tailor-made solutions, we consistently take into account the sprocket as it has a significant influence on the lifetime of the chain. The precision of the sprocket geometry and the surface of the material must be finely tuned to the chain. In this vein, we have developed chain systems with matching sprockets which reliably withstand even the highest loads.

Perfect engineering

From the production of the individual components made of high-grade steel strips up to the final installation of the chains – the entire production is based at our headquarters in Hagen. This has equipped us with comprehensive manufacturing expertise over the years. The result: we design the majority of our plants ourselves.

We implement special requirements for our machinery ourselves or in cooperation with plant manufacturers. This consistent transfer of know-how enables us to achieve a maximum degree of perfection – and optimum results for our customers.

Sound application advice

In addition to our product and manufacturing know-how, we have also built up comprehensive expertise in the varied fields of applications of our chains. This has put us in a position to consider parameters in the planning phase which will only become relevant in the application but have a significant impact on the chains and sprockets. A lot of our customers value our competent application advice as a central element of their orders and involve us in the development of their systems and products already at an early stage. This enables us to provide our customers with optimum solutions which comply with – or even exceed – all their specifications and wishes.



For our future, we put our stakes on people, the environment and technology.

For us, the perfect solution is one which complies with our corporate philosophy of “People – Environment – Technology”. This guiding principle ensures that we always focus on sustainability. WIPPERMANN shows continuous SPIRIT through its entrepreneurial responsibility towards employees and the environment, which leads to future-orientated solutions.

As a family-run business, we focus on long-term perspectives, with future generations in mind. We therefore attach great importance to training and qualification opportunities as well as a comprehensive occupational health and safety management. Indeed, we have been well and truly exceeding legal standards since the 1970s.

We also leverage our technical know-how for the protection of the environment. The installation of energy recovery plants, for instance, enables us to heat the entire office building through the use of the waste heat generated by our manufacturing furnaces. Thanks to this and many other energy saving measures, we were able to reduce the company’s energy consumption by 70 percent.

We consider products optimal if they comply with both our strict quality and environmental standards and the high expectations of our customers. A profound know-how across all production steps, from the raw materials to the elaborate manufacturing processes through to application planning is paramount to our success.



Research and development



Our research activities are dedicated to developing products for future requirements and to open up new fields of applications in which the use of our chains has not been efficient thus far.

Product engineering



We develop complete sprocket-chain systems with perfectly matching components that provide optimum functionality of our customers’ drive systems.

Manufacturing engineering



We offer a manufacturing depth that is unparalleled in the industry and thus adapt a large proportion of our machinery to our special requirements.

Application advice



We can draw on a wealth of experience regarding our customers’ varied fields of application and provide our customers with advice for the development of their systems and products already at an early stage.



Quality made by WIPPERMANN

All over the world, our customers from the automotive, food, packaging and many other industries appreciate the high quality of our products and services. The proved WIPPERMANN quality can only be achieved through highest precision in our production and precisely tuned manufacturing processes.

The foundation of our top-quality products is already laid with the selection of our raw material suppliers. We choose partners who share our high quality standards. The raw materials are exclusively sourced from Western European countries, including a large number of regional suppliers. The geographical proximity to our suppliers ensures short transport routes and thus low emissions in the logistics chain – and enables us to inspect and control the quality assurance processes in order to achieve top quality. At our traditional location in Hagen, we exclusively manufacture our products with highly qualified experts and in a manufacturing depth that is unparalleled in the industry. This

makes us the only manufacturer of industrial chains and sprockets to have its products consistently made in Germany. A comprehensive sales network of subsidiary companies, sales agents and dealers ensure the availability of our products worldwide, quickly, and with unfailing reliability.

A holistic service rounds off our high quality standards: in addition to the fast response to customer queries and the competent application advice, we also convince our customers through long-term support, e.g. during installation, maintenance and repair of their systems.



We want to know it all

Chains are technically sophisticated products which must fulfill highest demands over long periods of time. Each link in the chain is responsible for the functionality of the whole system. This is why we continuously evaluate the results of our work by taking samples from every batch and testing them for various parameters. With our state-of-the-art digital measuring systems, we test the properties of the individual chain plates for instance: the systems measure the hardness value of the link plates at more than 10,000 spots and provide information on the load-bearing capacity. This delivers an extremely accurate determination of the hardness profile of highly resistant components.

What's more, our research activities are targeted on finding solutions for future applications. One key objective is to combine previously incompatible product properties, such as freedom from maintenance and an extremely long lifetime life under high loads, by using innovative materials and manufacturing processes. In the context of our research activities, we have established development partnerships with leading institutes and manufacturers of special primary products. This enables us to create technical innovations which surprise our customers – and open up new fields of application for our customers in which chains could not be used for technical or economic reasons thus far.



Premium chains and sprockets made in Germany

WIPPERMANN supplies customers worldwide. Therefore, we have subsidiaries in Europe, Africa and South America, in Russia and in Turkey. WIPPERMANN is also well-positioned in Germany: seven branch offices as well as 15 main distributors contribute to our company's success.

For the most varied applications of discerning customers, e.g.

- Agricultural machinery
- Assembly plants
- Car wash systems
- Container carriers
- Conveyors
- Food packaging plants
- Galvanizing plants
- High rack warehouse technology
- Laundry machines
- Lift trucks and hoisting
- Packaging machines
- Painting plants
- Plants for the pharmaceutical industry
- Production plants for the electrical industry
- Solar cleaning plants
- Warehouse and packaging plants
- Water-management facilities

Can't find your application? Please feel free to contact us! We will develop the perfect solution together with you.

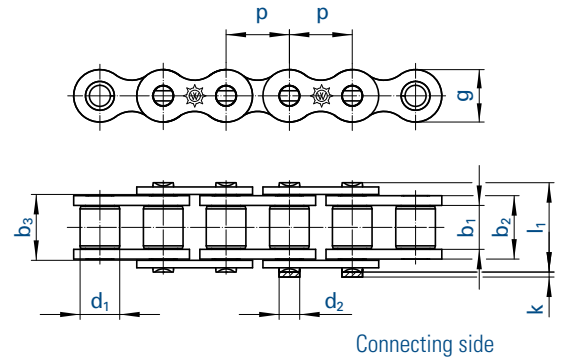

Chain		Pitch	Inner width	Inner link width	Outer plate width	Roller Ø	Pin Ø	Plate height	Projection over connecting link	Width over pin	Bearing area	Breaking load ISO	Breaking load	Weight	Connecting links		
ISO	p	b ₁ min.	b ₂ max.	b ₃ min.	d ₁ max.	d ₂ max.	g max.	k max.	l ₁ max.	f	F _B min.	F _B min.	q ≈	No.			
No.	Ind.	No.	mm	inch	mm	mm	mm	mm	mm	mm	cm ²	kN	kN	kg/m	No.		
440		03	5,000	-	2,50	4,15	4,25	3,20	1,49	4,1	2,5	7,4	0,06	2,2	2,2	0,08	11,15
445		04	6,000	-	2,80	4,10	4,20	4,00	1,85	5,0	2,9	7,4	0,08	3,0	3,0	0,15	11,15
450		05 B-1	8,000	-	3,00	4,77	4,90	5,00	2,31	7,1	3,1	8,6	0,11	5,0	5,5	0,18	11,15
453		-	9,525	3/8	3,30	5,45	5,58	6,00	2,78	9,0	3,1	9,6	0,15	8,0	8,2	0,26	11,15
454		-	9,525	3/8	3,94	6,70	6,83	6,35	3,28	9,0	3,3	11,6	0,22	9,0	9,4	0,36	11,12,15
455	¹	06 B-1	9,525	3/8	5,72	8,53	8,66	6,35	3,28	8,2	3,3	13,5	0,28	9,0	9,6	0,41	11,12,15
331		081	12,700	1/2	3,30	5,80	5,93	7,75	3,66	9,9	1,5	10,2	0,21	8,2	9,1	0,28	11,12,15
332		-	12,700	1/2	4,88	7,20	7,33	7,75	3,66	9,9	1,5	11,2	0,26	8,2	9,1	0,33	11,12,15
17		083	12,700	1/2	4,88	7,90	8,03	7,75	4,09	10,3	1,5	12,9	0,32	12,0	13,2	0,42	11,12,15
385		-	12,700	1/2	6,40	9,78	9,91	7,75	3,97	11,5	3,9	15,4	0,38	16,0	17,1	0,50	11,12,15
461		-	12,700	1/2	6,40	9,93	10,06	8,51	4,45	11,8	3,9	15,8	0,44	18,0	18,6	0,66	11,12,15
462		08 B-1	12,700	1/2	7,75	11,30	11,43	8,51	4,45	11,8	3,9	17,0	0,50	18,0	18,6	0,70	11,12,15
500		-	15,875	5/8	6,48	10,08	10,21	10,16	5,08	14,7	4,1	16,4	0,51	22,4	27,5	0,78	11,12,15
501		10 B-1	15,875	5/8	9,65	13,28	13,41	10,16	5,08	14,7	4,1	19,6	0,67	22,4	27,0	0,91	11,12,15
513		12 B-1	19,050	3/4	11,68	15,62	15,75	12,07	5,72	16,1	4,6	22,7	0,89	29,0	31,0	1,18	11,12,15
548		16 B-1	25,400	1	17,02	25,40	25,60	15,88	8,28	21,0	5,4	36,1	2,10	60,0	72,0	2,68	11,111,12
552		-	30,000	-	17,02	25,40	25,60	15,88	8,28	21,0	5,4	36,1	2,10	60,0	72,0	2,50	11,111,12
563		20 B-1	31,750	1 1/4	19,56	29,00	29,20	19,05	10,19	26,4	6,1	43,2	2,96	95,0	105,0	3,50	11,111,12
596		24 B-1	38,100	1 1/2	25,40	37,90	38,20	25,40	14,63	33,4	6,6	53,4	5,54	160,0	180,0	6,80	111,12
613		28 B-1	44,450	1 3/4	30,99	46,50	46,80	27,94	15,90	37,0	7,4	65,1	7,39	200,0	230,0	8,50	111,12
652		32 B-1	50,800	2	30,99	45,50	45,80	29,21	17,81	42,2	7,9	67,4	8,10	250,0	276,0	10,50	111,12
671		40 B-1	63,500	2 1/2	38,10	55,70	56,00	39,37	22,89	52,9	10,0	82,6	12,75	355,0	405,0	16,40	111,12
679		48 B-1	76,200	3	45,72	70,50	71,00	48,26	29,24	63,8	10,0	99,1	20,61	560,0	630,0	25,00	111

Electrogalvanised or nickel-plated chains on request. In this case chains may only have 80 % of the tensile strength.

¹ with straight side plates

For details on orders and enquiries see page 131. Standard sprockets as of page 78.
Information on the selection of chain sizes and drives as of page 118.

Connecting links: According to ISO (...)



No. 4 (B)
Inner link

No. 7 (A)
Outer link
(to be riveted)

No. 11 (E)
Spring clip
connecting link

No. 111 (S)
Connecting link
with cottered pin

No. 12 (L)
Single
cranked link

No. 15 (C)
Double
cranked link

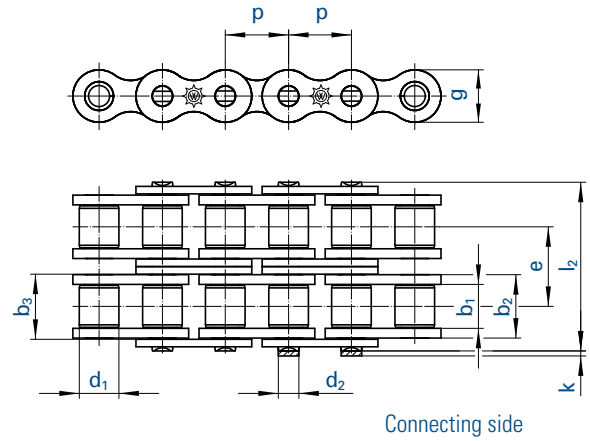

Chain		Pitch	Inner width	Inner link width	Outer plate width	Roller Ø	Pin Ø	Transverse pitch	Plate height	Projection over connecting link	Width over pin	Bearing area	Breaking load ISO	Breaking load	Weight	Connecting links		
No.	Ind.	ISO	p	b ₁ min.	b ₂ max.	b ₃ min.	d ₁ max.	d ₂ max.	e	g max.	k max.	l ₂ max.	f	F _B min.	F _B min.	q ≈	No.	
		No.	mm	inch	mm	mm	mm	mm	mm	mm	mm	mm	cm ²	kN	kN	kg/m	No.	
D 445		-	6,000	-	2,80	4,10	4,25	4,00	1,85	5,50	5,0	2,9	13,3	0,14	5,0	5,0	0,23	11,15
D 450		05 B-2	8,000	-	3,00	4,77	4,90	5,00	2,31	5,64	7,1	3,1	14,3	0,22	7,8	8,2	0,36	11,15
D 455	¹	06 B-2	9,525	3/8	5,72	8,53	8,66	6,35	3,28	10,24	8,2	3,3	23,8	0,56	16,9	17,4	0,86	11,12,15
D 462		08 B-2	12,700	1/2	7,75	11,30	11,43	8,51	4,45	13,92	11,8	3,9	31,0	1,01	32,0	37,0	1,36	11,12,15
D 501		10 B-2	15,875	5/8	9,65	13,28	13,41	10,16	5,08	16,59	14,7	4,1	36,2	1,34	44,5	54,0	1,82	11,12,15
D 513		12 B-2	19,050	3/4	11,68	15,62	15,75	12,07	5,72	19,46	16,1	4,6	42,2	1,79	57,8	63,0	2,38	11,12,15
D 548		16 B-2	25,400	1	17,02	25,40	25,60	15,88	8,28	31,88	21,0	5,4	68,0	4,21	106,0	140,0	5,30	11,111,12
D 563		20 B-2	31,750	1 1/4	19,56	29,00	29,20	19,05	10,19	36,45	26,4	6,1	79,0	5,91	170,0	210,0	7,30	11,111,12
D 596		24 B-2	38,100	1 1/2	25,40	37,90	38,20	25,40	14,63	48,36	33,4	6,6	101,0	11,09	280,0	360,0	13,40	111,12
D 613		28 B-2	44,450	1 3/4	30,99	46,50	46,80	27,94	15,90	59,56	37,0	7,4	124,0	14,79	360,0	443,0	16,60	111,12
D 652		32 B-2	50,800	2	30,99	45,50	45,80	29,21	17,81	58,55	42,2	7,9	126,0	16,21	450,0	530,0	21,00	111,12
D 671		40 B-2	63,500	2 1/2	38,10	55,70	56,00	39,37	22,89	72,29	52,9	10,0	154,0	25,50	630,0	806,0	32,60	111,12
D 679		48 B-2	76,200	3	45,72	70,50	71,00	48,26	29,24	91,21	63,8	10,0	190,0	41,23	1000,0	1100,0	50,00	111

Electrogalvanised or nickel-plated chains on request. In this case chains may only have 80 % of the tensile strength.

¹ with straight side plates

For details on orders and enquiries see page 131. Standard sprockets as of page 78. Information on the selection of chain sizes and drives as of page 118.

Connecting links: According to ISO (...)



No. 4 (B)
Inner link



No. 7 (A)
Outer link
(to be riveted)



No. 11 (E)
Spring clip
connecting link



No. 111 (S)
Connecting link
with cottered pin



No. 12 (L)
Single
cranked link



No. 15 (C)
Double
cranked link

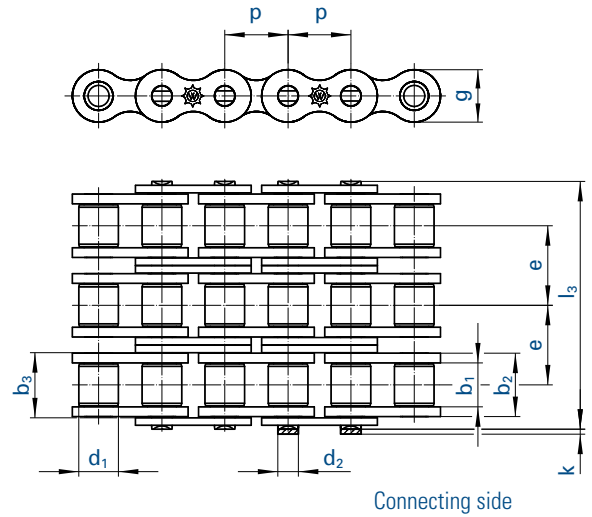

Chain		Pitch	Inner width	Inner link width	Outer plate width	Roller Ø	Pin Ø	Transverse pitch	Plate height	Projection over connecting link	Width over pin	Bearing area	Breaking load ISO	Breaking load	Weight	Connecting links		
	ISO	p	b ₁ min.	b ₂ max.	b ₃ min.	d ₁ max.	d ₂ max.	e	g max.	k max.	l ₃ max.	f	F _B min.	F _B min.	q ≈	No.		
No.	Ind.	No.	mm	inch	mm	mm	mm	mm	mm	mm	mm	cm ²	kN	kN	kg/m	No.		
T 450		05 B-3	8,000		3,00	4,77	4,90	5,00	2,31	5,64	7,1	3,1	19,9	0,33	11,1	11,1	0,54	11,15
T 455	¹	06 B-3	9,525	$\frac{3}{8}$	5,72	8,53	8,66	6,35	3,28	10,24	8,2	3,3	34,0	0,81	24,9	24,9	1,18	11,12,15
T 462		08 B-3	12,700	$\frac{1}{2}$	7,75	11,30	11,43	8,51	4,45	13,92	11,8	3,9	44,9	1,51	47,5	56,0	2,01	11,12,15
T 501		10 B-3	15,875	$\frac{5}{8}$	9,65	13,28	13,41	10,16	5,08	16,59	14,7	4,1	52,8	2,02	66,7	80,0	2,70	11,12,15
T 513		12 B-3	19,050	$\frac{3}{4}$	11,68	15,62	15,75	12,07	5,72	19,46	16,1	4,6	61,7	2,68	86,7	94,0	3,12	11,12,15
T 548		16 B-3	25,400	1	17,02	25,40	25,60	15,88	8,28	31,88	21,0	5,4	99,9	6,31	160,0	211,0	7,50	11,111,12
T 563		20 B-3	31,750	1 $\frac{1}{4}$	19,56	29,00	29,20	19,05	10,19	36,45	26,4	6,1	116,0	8,87	250,0	300,0	10,60	11,111,12
T 596		24 B-3	38,100	1 $\frac{1}{2}$	25,40	37,90	38,20	25,40	14,63	48,36	33,4	6,6	150,0	16,63	425,0	523,0	20,00	111,12
T 613		28 B-3	44,450	1 $\frac{3}{4}$	30,99	46,50	46,80	27,94	15,90	59,56	37,0	7,4	184,0	22,18	530,0	660,0	25,00	111,12
T 652		32 B-3	50,800	2	30,99	45,50	45,80	29,21	17,81	58,55	42,2	7,9	184,0	24,31	670,0	800,0	32,00	111,12
T 671		40 B-3	63,500	2 $\frac{1}{2}$	38,10	55,70	56,00	39,37	22,89	72,29	52,9	10,0	227,0	38,25	950,0	1140,0	48,70	111,12
T 679		48 B-3	76,200	3	45,72	70,50	71,00	48,26	29,24	91,21	63,8	10,0	281,0	61,84	1500,0	1720,0	75,00	111

Electrogalvanised or nickel-plated chains on request. In this case chains may only have 80 % of the tensile strength.

¹ with straight side plates

For details on orders and enquiries see page 131. Standard sprockets as of page 78. Information on the selection of chain sizes and drives as of page 118.

Connecting links: According to ISO (...)



No. 4 (B)
Inner link



No. 7 (A)
Outer link
(to be riveted)



No. 11 (E)
Spring clip
connecting link



No. 111 (S)
Connecting link
with cottered pin



No. 12 (L)
Single
cranked link



No. 15 (C)
Double
cranked link

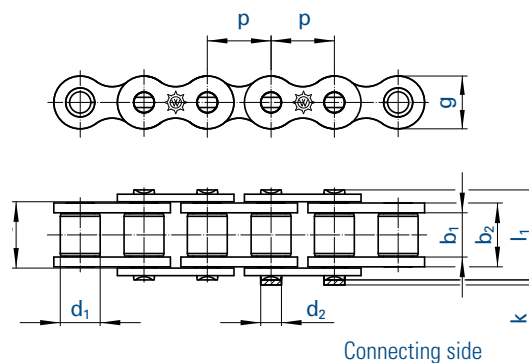
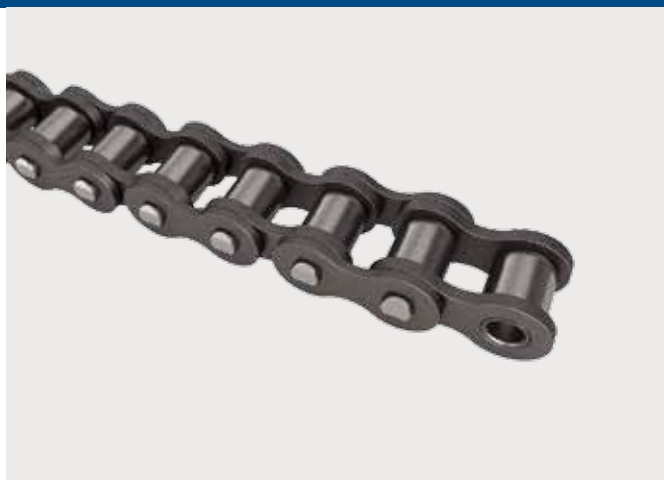

Chain		Pitch	Inner width	Inner link width	Outer plate width	Roller Ø	Pin Ø	Plate height	Projection over connecting link	Width over pin	Bearing area	Breaking load ISO	Breaking load	Weight	Connecting links		
	ISO	p	b ₁ min.	b ₂ max.	b ₃ min.	d ₁ max.	d ₂ max.	g max.	k max.	l ₁ max.	f	F _B min.	F _B min.	q ≈	No.		
No.	Ind.	No.	mm	inch	mm	mm	mm	mm	mm	mm	cm ²	kN	kN	kg/m	No.		
25	²	04 C-1	6,350	¼	3,18	4,80	4,85	3,30	2,31	6,0	2,5	9,0	0,11	3,5	3,5	0,13	11,15
35	²	06 C-1	9,525	⅜	4,68	7,47	7,52	5,08	3,58	9,1	3,3	13,2	0,27	7,9	10,2	0,35	11,12,15
40		08 A-1	12,700	½	7,85	11,15	11,28	7,95	3,96	12,0	3,9	17,8	0,44	14,1	16,5	0,60	11,12,15
50		10 A-1	15,875	⅝	9,40	13,80	13,93	10,16	5,08	15,0	4,1	21,8	0,70	22,2	30,0	1,01	11,12,15
60	⁹	12 A-1	19,050	¾	12,57	17,70	17,85	11,91	5,94	18,0	4,6	26,9	1,05	31,8	40,0	1,58	11,111,12,15
80	⁹	16 A-1	25,400	1	15,75	22,50	22,70	15,88	7,92	24,1	5,4	33,5	1,78	56,7	69,0	2,36	11,111,12
100	⁹	20 A-1	31,750	1 ¼	18,90	27,40	27,60	19,05	9,53	30,1	6,1	41,1	2,61	88,5	92,5	3,80	111,12
120	⁹	24 A-1	38,100	1 ½	25,22	35,30	35,60	22,23	11,10	36,2	6,6	50,8	3,92	127,0	139,0	5,40	111,12
140	⁹	28 A-1	44,450	1 ¾	25,22	37,00	37,30	25,40	12,70	42,2	7,4	54,9	4,70	172,4	178,5	7,30	111,12
160	⁹	32 A-1	50,800	2	31,55	45,00	45,30	28,58	14,27	48,2	7,9	65,5	6,42	226,8	231,0	9,90	111,12
200	⁹	40 A-1	63,500	2 ½	37,85	54,70	55,00	39,68	19,84	60,3	10,0	80,3	10,85	353,8	387,0	16,50	111,12

Heavy duty design with reinforced side plates and enlarged bearing areas

50 H		-	15,875	⅝	9,40	14,60	14,73	10,16	5,08	15,0	4,1	23,4	0,75	22,2	32,0	1,18	11
60 H	⁹	-	19,050	¾	12,57	19,45	19,60	11,91	5,94	18,0	4,6	28,9	1,16	31,8	42,0	1,94	11
80 H	⁹	-	25,400	1	15,75	24,28	24,48	15,88	7,92	24,1	5,4	37,0	1,92	56,7	72,0	3,04	111
100 H	⁹	-	31,750	1 ¼	18,90	29,10	29,30	19,05	9,53	30,1	6,1	44,0	2,77	88,5	96,0	4,25	111
120 H	⁹	-	38,100	1 ½	25,22	37,00	37,30	22,23	11,10	36,2	6,6	54,0	4,13	127,0	141,0	6,40	111
140 H	⁹	-	44,450	1 ¾	25,22	38,70	39,00	25,40	12,70	42,2	7,4	58,0	4,94	172,4	180,0	8,30	111
160 H	⁹	-	50,800	2	31,55	46,90	47,20	28,58	14,27	48,2	7,9	68,0	6,70	226,8	233,0	11,50	111
200 H	⁹	-	63,500	2 ½	37,85	57,60	57,90	39,68	19,84	60,3	10,0	84,0	11,60	353,8	400,0	20,00	111

Electrogalvanised or nickel-plated chains on request. In this case chains may only have 80 % of the tensile strength.

² without rollers ⁹ dismantlable designs (with cottered/split pins) on request

For details on orders and enquiries see page 131. Standard sprockets as of page 78.
Information on the selection of chain sizes and drives as of page 118.

Connecting links: According to ISO (...)



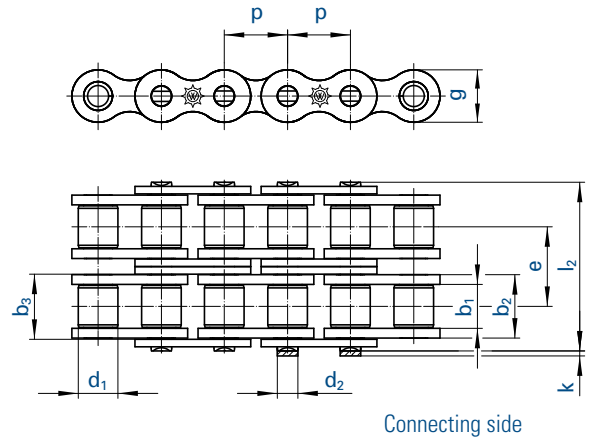

Chain		Pitch	Inner width	Inner link width	Outer plate width	Roller Ø	Pin Ø	Transverse pitch	Plate height	Projection over connecting link	Width over pin	Bearing area	Breaking load ISO	Breaking load	Weight	Connecting links		
No.	Ind.	ISO	p		b ₁ min.	b ₂ max.	b ₃ min.	d ₁ max.	d ₂ max.	e	g max.	k max.	l ₂ max.	f	F _B min.	F _B min.	q ≈	No.
		No.	mm	inch	mm	mm	mm	mm	mm	mm	mm	mm	mm	mm	cm ²	kN	kN	kg/m
35-2	²	06 C-2	9,525	3/8	4,68	7,47	7,52	5,08	3,58	10,13	9,0	3,3	23,4	0,53	15,8	17,0	0,70	11,12,15
40-2		08 A-2	12,700	1/2	7,85	11,15	11,28	7,95	3,96	14,38	12,0	3,9	32,3	0,88	28,2	29,7	1,20	11,12,15
50-2		10 A-2	15,875	5/8	9,40	13,80	13,93	10,16	5,08	18,11	15,0	4,1	39,9	1,40	44,4	62,0	1,78	11,12,15
60-2	⁹	12 A-2	19,050	3/4	12,57	17,70	17,85	11,91	5,94	22,78	18,0	4,6	49,8	2,10	63,6	76,0	3,15	11,111,12,15
80-2	⁹	16 A-2	25,400	1	15,75	22,50	22,70	15,88	7,92	29,29	24,1	5,4	62,7	3,56	113,4	135,0	4,90	11,111,12,15
100-2	⁹	20 A-2	31,750	1 1/4	18,90	27,40	27,60	19,05	9,53	35,76	30,1	6,1	77,0	5,22	177,0	205,0	7,60	111,12
120-2	⁹	24 A-2	38,100	1 1/2	25,22	35,30	35,60	22,23	11,10	45,44	36,2	6,6	96,3	7,84	254,0	290,0	10,80	111,12
140-2	⁹	28 A-2	44,450	1 3/4	25,22	37,00	37,30	25,40	12,70	48,87	42,2	7,4	103,0	9,40	344,8	357,0	14,30	111,12
160-2	⁹	32 A-2	50,800	2	31,55	45,00	45,30	28,58	14,27	58,55	48,2	7,9	124,0	12,84	453,6	455,0	19,40	111,12
200-2	⁹	40 A-2	63,500	2 1/2	37,85	54,70	55,00	39,68	19,84	71,55	60,3	10,0	151,0	21,70	707,6	730,0	33,00	111,12

Electrogalvanised or nickel-plated chains on request. In this case chains may only have 80 % of the tensile strength.

² without rollers ⁹ dismountable designs (with cottered/split pins) on request

For details on orders and enquiries see page 131. Sprockets on request.
Information on the selection of chain sizes and drives as of page 118.

Connecting links: According to ISO (...)



No. 4 (B)
Inner link



No. 7 (A)
Outer link
(to be riveted)



No. 11 (E)
Spring clip
connecting link



No. 111 (S)
Connecting link
with cottered pin



No. 12 (L)
Single
cranked link



No. 15 (C)
Double
cranked link

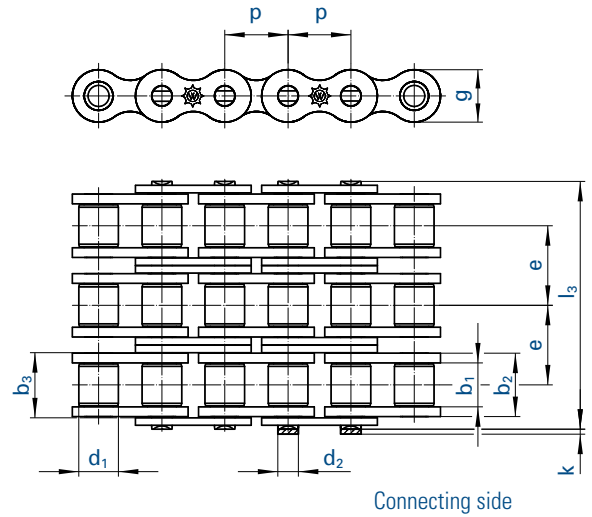
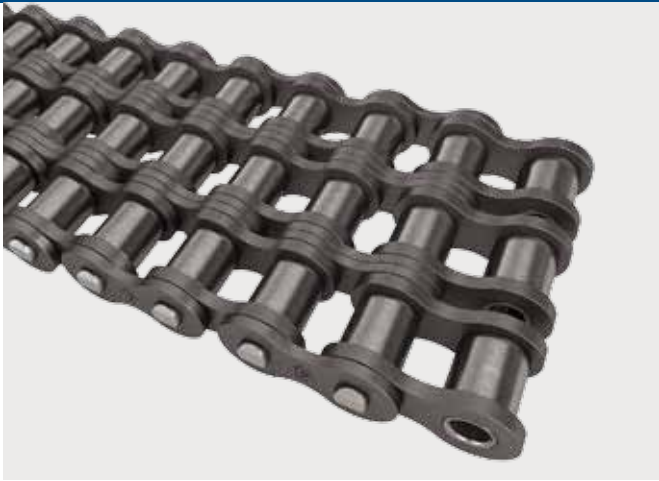

Connecting side

Chain		Pitch	Inner width	Inner link width	Outer plate width	Roller Ø	Pin Ø	Transverse pitch	Plate height	Projection over connecting link	Width over pin	Bearing area	Breaking load ISO	Breaking load	Weight	Connecting links		
No.	Ind.	ISO	p		b ₁ min.	b ₂ max.	b ₃ min.	d ₁ max.	d ₂ max.	e	g max.	k max.	l ₃ max.	f	F _B min.	F _B min.	q ≈	No.
		No.	mm	inch	mm	mm	mm	mm	mm	mm	mm	mm	mm	mm	cm ²	kN	kN	kg/m
35-3	²	06 C-3	9,525	3/8	4,68	7,47	7,52	5,08	3,58	10,13	9,0	3,3	33,5	0,80	23,7	25,5	1,05	11,12,15
40-3		08 A-3	12,700	1/2	7,85	11,15	11,28	7,95	3,96	14,38	12,0	3,9	46,7	1,32	42,3	41,2	1,80	11,12,15
50-3		10 A-3	15,875	5/8	9,40	13,80	13,93	10,16	5,08	18,11	15,0	4,1	57,9	2,10	66,6	88,0	3,02	11,12,15
60-3	⁹	12 A-3	19,050	3/4	12,57	17,70	17,85	11,91	5,94	22,78	18,0	4,6	72,6	3,15	95,4	105,0	4,70	11,11,12,15
80-3	⁹	16 A-3	25,400	1	15,75	22,50	22,70	15,88	7,92	29,29	24,1	5,4	91,7	5,35	170,1	193,0	7,50	11,11,12,15
100-3	⁹	20 A-3	31,750	1 1/4	18,90	27,40	27,60	19,05	9,53	35,76	30,1	6,1	113,0	7,83	265,5	305,0	11,20	111,12
120-3	⁹	24 A-3	38,100	1 1/2	25,22	35,30	35,60	22,23	11,10	45,44	36,2	6,6	141,0	11,76	381,0	410,0	16,10	111,12
140-3	⁹	28 A-3	44,450	1 3/4	25,22	37,00	37,30	25,40	12,70	48,87	42,2	7,4	152,0	14,10	517,2	520,0	21,40	111,12
160-3	⁹	32 A-3	50,800	2	31,55	45,00	45,30	28,58	14,27	58,55	48,2	7,9	182,0	19,26	680,4	685,0	29,10	111,12
200-3	⁹	40 A-3	63,500	2 1/2	37,85	54,70	55,00	39,68	19,84	71,55	60,3	10,0	223,0	32,56	1061,4	1095,0	50,00	111,12

Electrogalvanised or nickel-plated chains on request. In this case chains may only have 80 % of the tensile strength.

² without rollers ⁹ dismantlable designs (with cottered/split pins) on request

For details on orders and enquiries see page 131. Sprockets on request.
Information on the selection of chain sizes and drives as of page 118.

Connecting links: According to ISO (...)



No. 4 (B)
Inner link



No. 7 (A)
Outer link
(to be riveted)



No. 11 (E)
Spring clip
connecting link



No. 111 (S)
Connecting link
with cottered pin



No. 12 (L)
Single
cranked link



No. 15 (C)
Double
cranked link

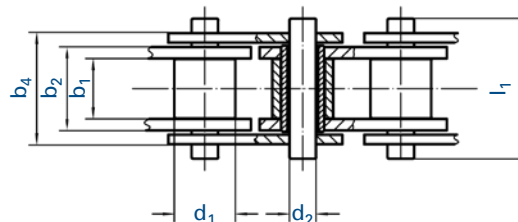
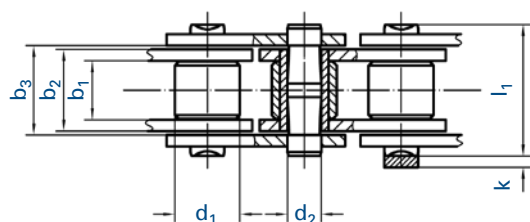
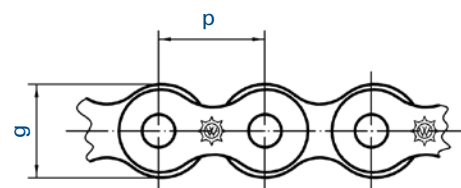
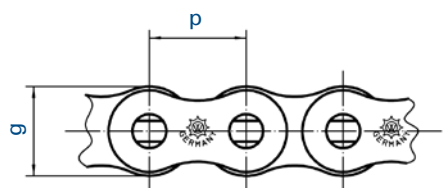
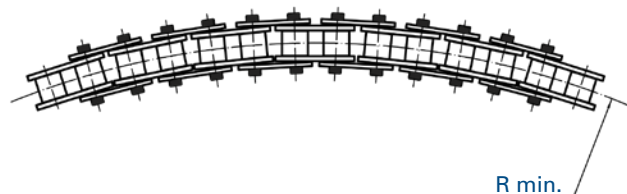

Main dimensions according to ISO 606 (European type)

Chain		Pitch	Inner width	Inner link width	Outer plate width	Roller Ø	Pin Ø	Plate height	Projection over connecting link	Width over pin	Bearing area	Breaking load	Smallest possible side bow radius
⚙️		p	b ₁ min.	b ₂ max.	b ₃ min.	d ₁ max.	d ₂ max.	g max.	k max.	l ₁ max.	f	F _B min.	r min.
No.	Ind.	mm	mm	mm	mm	mm	mm	mm	mm	mm	cm ²	kN	mm
462 SB		12,700	7,75	11,30	11,70	8,51	4,45	11,80	3,90	17,20	0,08	18,0	300
501 SB		15,875	9,65	13,28	13,70	10,16	5,08	14,70	4,10	19,60	0,09	22,4	400
513 SB		19,050	11,68	15,62	16,10	12,07	5,72	16,10	4,60	22,70	0,12	29,0	450
548 SB		25,400	17,02	25,40	27,20	15,88	8,28	21,00	5,40	37,40	0,21	60,0	500

Main dimensions according to ISO 606 (American type)

Chain		Pitch	Inner width	Inner link width	Outer plate width	Roller Ø	Pin Ø	Plate height	Projection over connecting link	Width over pin	Bearing area	Breaking load	Smallest possible side bow radius
⚙️		p	b ₁ min.	b ₂ max.	b ₃ min.	d ₁ max.	d ₂ max.	g max.	k max.	l ₁ max.	f	F _B min.	r min.
No.	Ind.	mm	mm	mm	mm	mm	mm	mm	mm	mm	cm ²	kN	mm
ASA 40		12,70	7,85	11,15	14,40	7,95	3,45	12,00		18,20	0,38	10,5	250
ASA 40 RF		12,70	7,85	11,15	14,40	7,95	3,45	12,00		18,20	0,38	6,3	250
ASA 61	¹	19,05	13,00	17,70	22,70	11,91	5,08	15,90		29,10	0,89	28,0	400
ASA 61 RF	¹	19,05	13,00	17,70	22,70	11,91	5,08	15,90		29,10	0,89	15,0	400

¹ with straight inner plate



Simplex chains

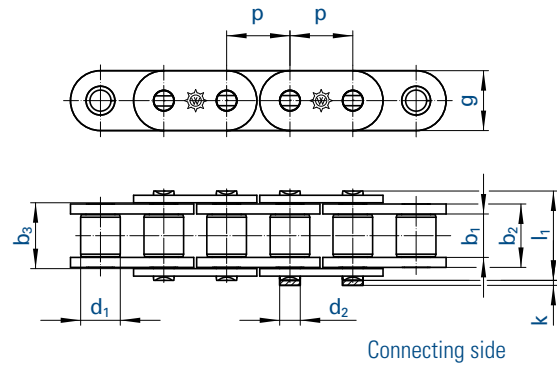

Connecting side

Triplex chains

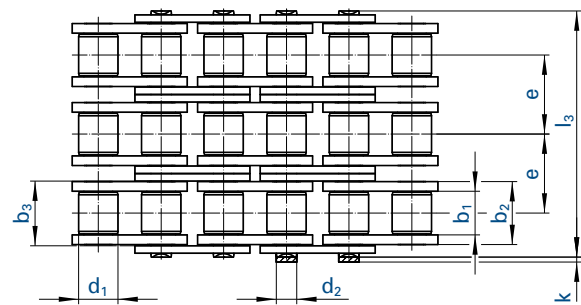

Connecting side

Duplex chains

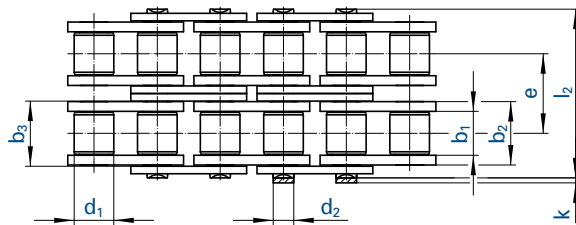

Connecting side

Chain		Pitch		Inner width	Inner link width	Outer plate width	Roller Ø	Pin Ø	Transverse pitch	Plate height	Projection over connecting link	Width over pin	Bearing area	Breaking load ISO	Breaking load	Weight	Connecting links
		p		b ₁ min.	b ₂ max.	b ₃ min.	d ₁ max.	d ₂ max.	e	g max.	k max.	l max.	f	F _B min.	F _B min.	q ≈	No.
No.	Ind.	mm	inch	mm	mm	mm	mm	mm	mm	mm	mm	mm	cm ²	kN	kN	kg/m	No.
455 GL		9,525	3/8	5,72	8,53	8,66	6,35	3,28	-	8,2	3,3	13,5	0,28	9,0	9,6	0,41	4,7,11,12,15
462 GL		12,700	1/2	7,75	11,30	11,43	8,51	4,45	-	11,5	3,9	17,0	0,50	18,0	18,6	0,78	4,7,11,12
501 GL		15,875	5/8	9,65	13,28	13,41	10,16	5,08	-	14,2	4,1	19,6	0,67	22,4	27,0	1,03	4,7,11
513 GL		19,050	3/4	11,68	15,62	15,75	12,07	5,72	-	15,5	4,6	22,7	0,89	29,0	31,0	1,29	4,7,11,12
60 GL		19,050	3/4	12,57	17,70	17,85	11,91	5,94	-	18,0	4,6	26,9	1,05	31,8	41,0	1,58	4,7,11
60 HGL		19,050	3/4	12,57	19,45	19,60	11,91	5,94	-	18,0	4,6	28,9	1,16	31,8	41,0	1,94	4,7,11
548 GL		25,400	1	17,02	25,40	25,60	15,88	8,28	-	24,0	5,4	36,1	2,10	60,0	72,0	3,29	4,7,11
548 GLS		25,400	1	17,02	25,40	25,60	15,88	8,28	-	21,0	5,4	36,1	2,10	60,0	72,0	2,90	4,7,11,12
563 GL		31,750	1 1/4	19,56	29,00	29,20	19,05	10,19	-	26,4	6,1	43,2	2,95	95,0	105,0	4,13	4,7,11,12
596 GL		38,100	1 1/2	25,40	37,90	38,20	25,4	14,63	-	33,4	6,6	53,4	5,54	160,0	180,0	7,34	4,7,11,12
455 GL-2		9,525	3/8	5,72	8,53	8,66	6,35	3,28	10,24	8,2	3,3	23,8	0,56	16,9	17,4	0,86	4,7,11,12,15
462 GL-2		12,700	1/2	7,75	11,30	11,43	8,51	4,45	13,92	11,5	3,9	31,0	1,01	32,0	37,0	1,50	4,7,11,12
501 GL-2		15,875	5/8	9,65	13,28	13,41	10,16	5,08	16,59	14,2	4,1	36,2	1,34	44,5	54,0	2,00	4,7,11
513 GL-2		19,050	3/4	11,68	15,62	15,75	12,07	5,72	19,46	15,5	4,6	42,2	1,79	57,8	63,0	2,62	4,7,11,12
60 GL-2		19,050	3/4	12,57	17,70	17,85	11,91	5,94	22,78	18,0	4,6	49,8	2,10	63,6	76,0	3,08	4,7,11
548 GL-2		25,400	1	17,02	25,40	25,60	15,88	8,28	31,88	24,0	5,4	68,0	4,21	106,0	140,0	6,59	4,7,11
548 GLS-2		25,400	1	17,02	25,40	25,60	15,88	8,28	31,88	21,0	5,4	68,0	4,21	106,0	140,0	5,85	4,7,11
563 GL-2		31,750	1 1/4	19,56	29,00	29,20	19,05	10,19	36,45	26,4	6,1	79,0	5,91	170,0	210,0	8,03	4,7,11,12
596 GL-2		38,100	1 1/2	25,40	37,92	38,20	25,4	14,63	48,36	33,4	6,6	101,0	11,09	280,0	360,0	14,47	4,7,11,12
455 GL-3		9,525	3/8	5,72	8,53	8,66	6,35	3,28	10,24	8,2	3,3	34,0	0,81	24,9	24,9	1,30	4,7,11,12,15
462 GL-3		12,700	1/2	7,75	11,30	11,43	8,51	4,45	13,92	11,5	3,9	44,9	1,51	47,5	56,0	2,21	4,7,11,12
501 GL-3		15,875	5/8	9,65	13,28	13,41	10,16	5,08	16,59	14,2	4,1	52,8	2,02	66,7	80,0	2,97	4,7,11
513 GL-3		19,050	3/4	11,68	15,62	15,75	12,07	5,72	19,46	15,5	4,6	61,7	2,68	86,7	94,0	3,43	4,7,11,12
60 GL-3		19,050	3/4	12,57	17,70	17,85	11,91	5,94	22,78	18,0	4,6	72,6	3,15	95,4	105,0	4,58	4,7,11
548 GL-3		25,400	1	17,02	25,40	25,60	15,88	8,28	31,88	24,0	5,4	99,9	6,31	160,0	211,0	9,88	4,7,11
548 GLS-3		25,400	1	17,02	25,40	25,60	15,88	8,28	31,88	21,0	5,4	99,9	6,31	160,0	211,0	8,50	4,7,11
563 GL-3		31,750	1 1/4	19,56	29,00	29,20	19,05	10,19	36,45	26,4	6,1	116,0	8,87	250,0	300,0	11,66	4,7,11,12
596 GL-3		38,100	1 1/2	25,40	37,90	38,20	25,40	14,63	48,36	33,4	6,6	150,0	16,63	425,0	523,0	22,00	4,7,11,12

Electrogalvanised or nickel-plated chains on request. In this case chains may only have 80 % of the tensile strength.

For details on orders and enquiries see page 131. Standard sprockets as of page 78.
Information on the selection of chain sizes and drives as of page 118.



POM-Clips

The best protection for sensitive goods

These clips are suitable for mounting on roller chains (type series GL) and prevent the direct contact between the chain and the items to be transported. Furthermore, they enlarge the contact surface and they are therefore able to guarantee a particularly safe conveyance process.

The special design of the plastic clips also prevents a possible tilting in the deflections of the chain conveyor. In order to strengthen the clip fixing even more and thus increase safety, WIPPERMANN recommends the use of unriveted roller chains.

Technical features

- Stiff and durable thermoplastic
- Impact resistant
- Wear resistant
- Friction coefficient $\mu = 0,15 \dots 0,3$ (against steel)
- Max. sustained temperature 80°C
- Food approved
- Alkali-proof
- Hot-water-proof
- Not resistant against strong acids (pH < 4)
- Insoluble in many solvents, fuel and mineral oil
- Low bulking

Roller chains (Type GL) with POM-Clip

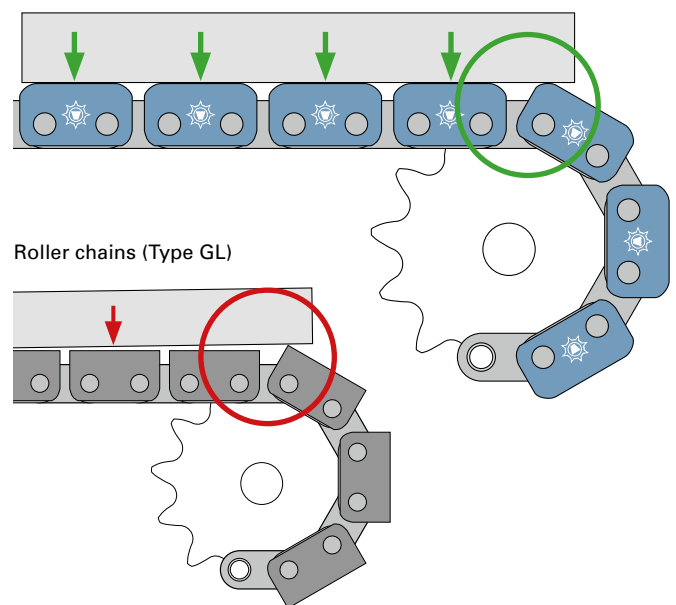

Benefits for application

- For simplex and duplex roller chains
- Protect sensitive goods from damage by the chain
- Wear resistant and durable POM
- No edge pressure at transfer points (see picture)
- High load capacity per clip
- Black clips for connecting links (mounting without spring clip)

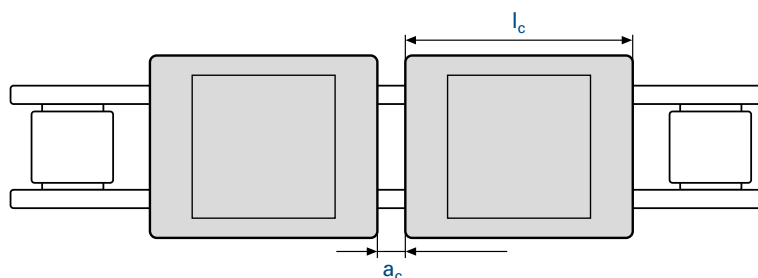
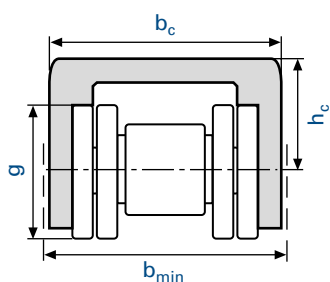

Chain			Plate height						max. vertical load per clip
⚙		ISO	g	a _c	b _c	b _{min}	h _c	l _c	
No.	Ind.	No.	mm	mm	mm	mm	mm	mm	kg
462 GL		08 B-1	11,5	3,50	19,7	22,0	9,3	21,9	70
D 462 GL		08 B-2	11,5	3,50	33,7	36,0	9,3	21,9	140
501 GL		10 B-1	14,2	1,55	22,6	25,0	12,5	30,2	90
D 501 GL		10 B-2	14,2	1,55	39,3	42,0	12,5	30,2	180
513 GL		12 B-1	15,5	3,90	25,4	28,0	13,2	34,2	110
D 513 GL		12 B-2	15,5	3,90	45,3	48,0	13,2	34,2	220
548 GLS		16 B-1	21,0	5,10	40,5	45,0	18,5	45,7	140
548 GL		Werksnorm	24,0	5,10	40,5	45,0	18,5	45,7	140
563 GL		20 B-1	26,5	10,40	47,0	50,0	23,2	53,4	180

Assembly of the clips at room temperature (> 15°C)

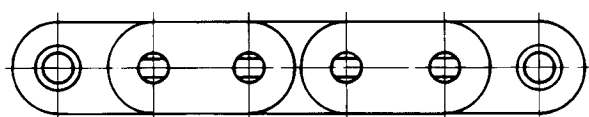

Correct chain for plastic clips
(Type series GL, preferably unriveted)

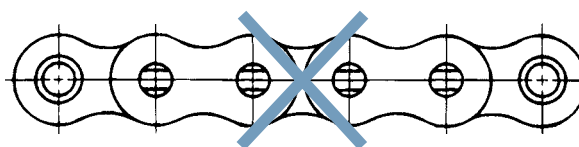

Wrong chain for plastic clips



Fixing by pin extensions, chains preferably unriveted

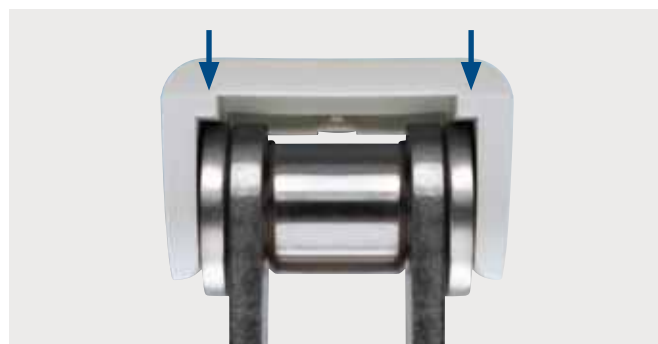

Top surface of the straight plates bear the load

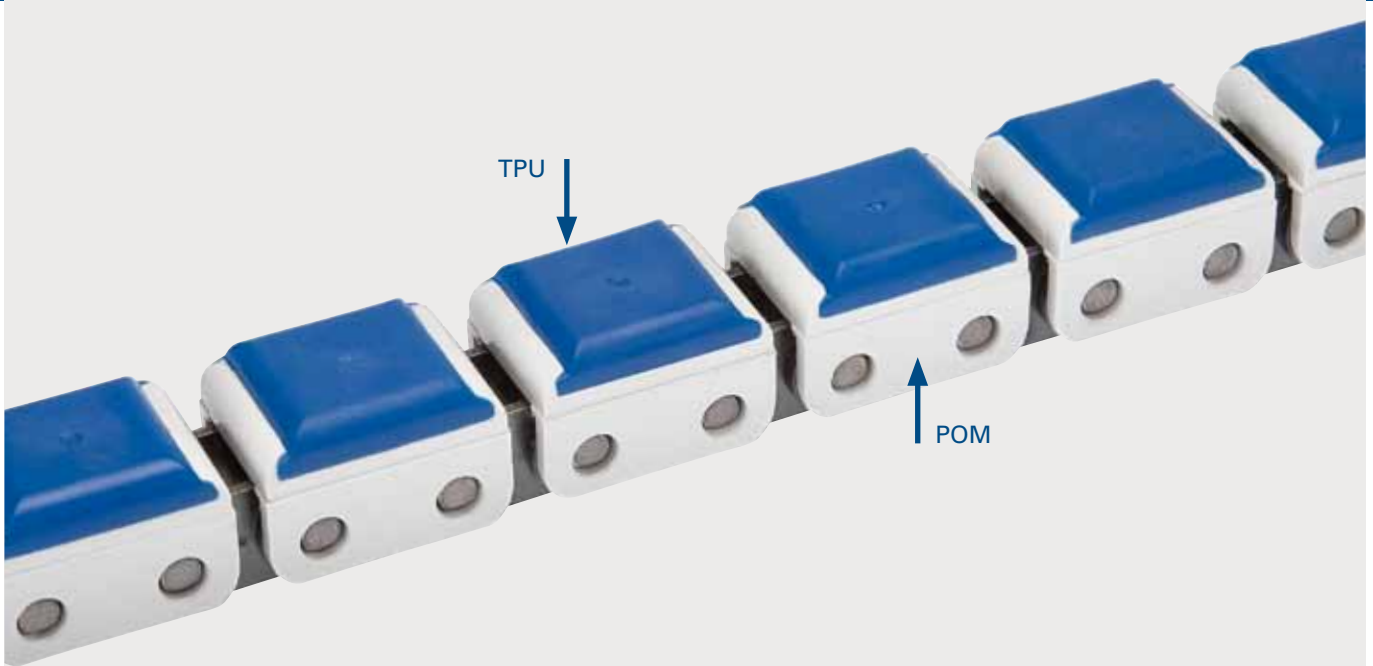

POM-Clips with elastomer

Slip-free conveyance process

For the conveyance of particularly delicate goods as well as for goods that slip easily, WIPPERMANN offers plastic clips with an overlay made of thermo-plastic elastomer (TPU) with a hardness of approximately 85 Shore A.

These clips significantly increase the adhesion friction coefficient between the conveyed item and the clip, and they can therefore ensure an absolutely slip-free conveyance process. On customers' request, hardness grades between 50 Shore A and 90 Shore A can be supplied.

Technical features

- POM-Clip: stiff, durable, impact resistant
- TPU-top: 85 Shore A
- Perfect junction between POM-Clip and TPU-top
- High friction, high abrasion resistance
- Max. sustained temperature 80°C
- Resistant against most oils and greases
- Low danger of hydrolysis

Benefits for application

- For chain 462GL, 513GL, 548GLS including MARATHON and Stainless Steel
- Basic clip POM, top surface TPU (85 Shore A)
- Protect sensitive goods from damage by the chain
- No edge pressure at transfer points (see picture)
- High coefficient of friction between clip and conveyed good
- High load capacity
- Mounting of connecting links with POM-clip and without spring clip

Roller chain (type GL) with POM clip including TPU overlay

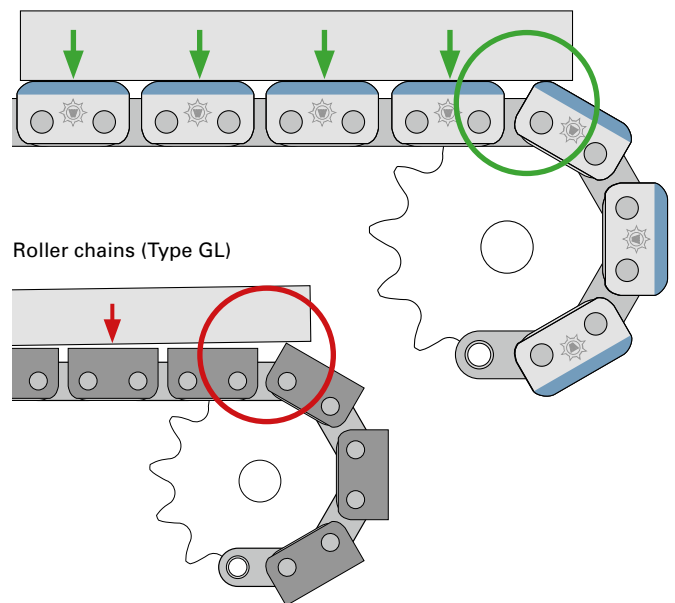

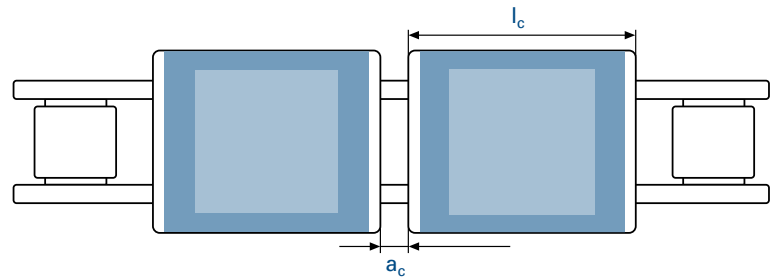
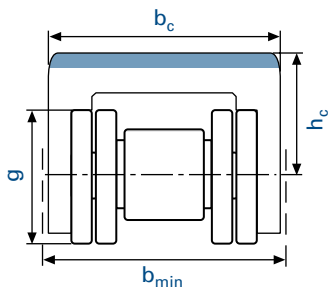

Chain			Plate height						max. vertical load per clip
⚙		ISO	g	a _c	b _c	b _{min}	h _c	l _c	kg
No.	Ind.	No.	mm	mm	mm	mm	mm	mm	
462 GL		08 B-1	11,5	3,4	19,5	22,0	13,0	21,9	70
513 GL		12 B-1	15,5	3,9	25,4	28,0	20,0	34,2	110
548 GLS		16 B-1	21,0	5,1	40,5	45,0	21,5	45,7	140

Assembly of the clips at room temperature (> 15°C)

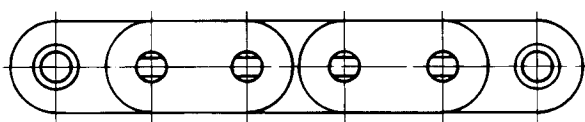

Correct chain for plastic clips
(Type series GL, preferably unriveted)

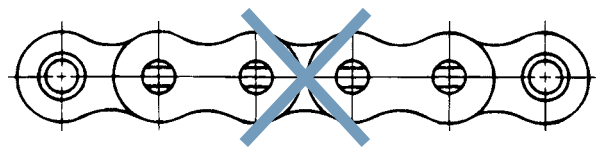

Wrong chain for plastic clips



Fixing by pin extension, preferably chains unriveted or with extended pins

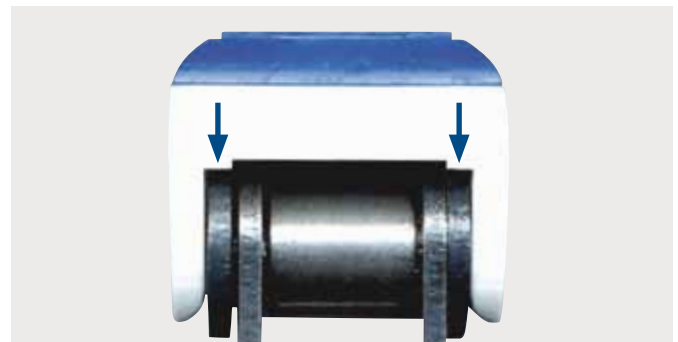

Top surfaces of the straight plates bear the load



Simplex chains

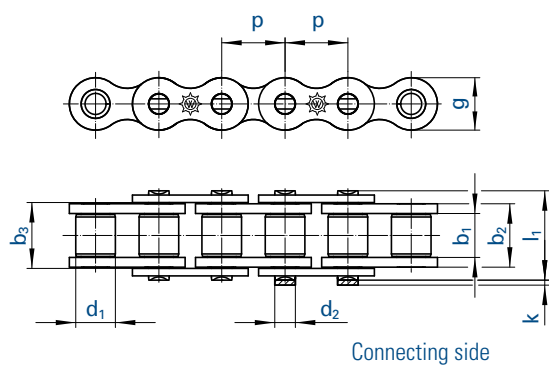

Simplex chains (Type GL)

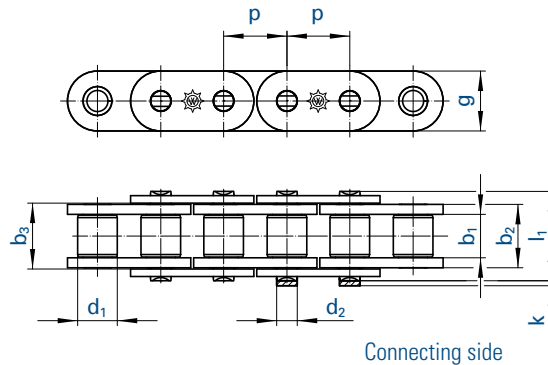

Duplex chains

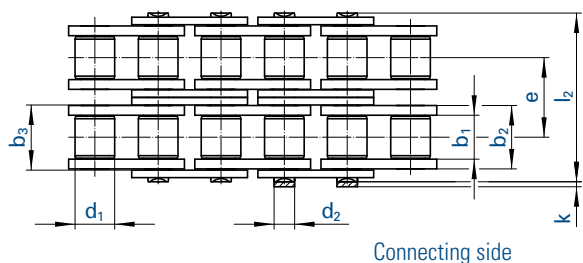

Triplex chains

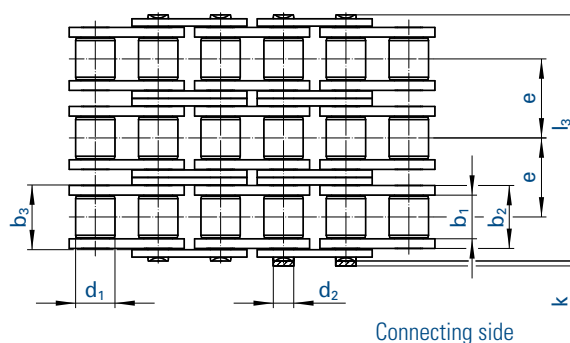

Chain		Pitch		Inner width	Inner link width	Outer plate width	Roller Ø	Pin Ø	Transverse pitch	Plate height	Projection over connecting link	Width over pin	Bearing area	Breaking load	Weight	Connecting links
⚙️		p		b ₁ min.	b ₂ max.	b ₃ min.	d ₁ max.	d ₂ max.	e	g max.	k max.	l max.	f	F _B min.	q ≈	
No.	Ind.	mm	inch	mm	mm	mm	mm	mm	mm	mm	mm	mm	cm ²	kN	kg/m	No.
548 GLX	¹	25,400	1	17,02	25,40	25,60	15,88	8,28	-	24,0	5,4	36,1	2,10	85,0	3,29	4,7,11,111
D548 GLX	¹	25,400	1	17,02	25,40	25,60	15,88	8,28	31,88	24,0	5,4	68,0	4,21	170,0	6,59	4,7,11,111
T548 GLX	¹	25,400	1	17,02	25,40	25,60	15,88	8,28	31,88	24,0	5,4	99,9	6,31	270,0	8,50	4,7,11,111
563 GLX	¹	31,750	1 ¼	19,56	29,00	29,20	19,05	10,19	-	26,4	6,1	43,2	2,95	123,0	4,13	4,7,11,111
D563 GLX	¹	31,750	1 ¼	19,56	29,00	29,20	19,05	10,19	36,45	26,4	6,1	79,0	5,91	240,0	8,03	4,7,11,111
T563 GLX	¹	31,750	1 ¼	19,56	29,00	29,20	19,05	10,19	36,45	26,4	6,1	116,0	8,87	350,0	11,66	4,7,11,111
596 R		38,100	1 ½	25,40	37,90	38,20	25,40	13,50	-	36,0	6,6	53,4	5,12	200,0	7,10	4,7,111
596 SX		38,100	1 ½	25,40	39,90	40,20	25,40	14,63	-	36,0	6,6	56,5	5,84	235,0	8,20	4,7,111
50 HX	¹⁴	15,875	5/8	9,40	14,60	14,73	10,16	5,08	-	15,0	4,1	23,4	0,75	33,4	1,18	4,7,11
60 HX	¹⁴	19,050	3/4	12,57	19,45	19,60	11,91	5,94	-	18,0	4,6	28,9	1,16	50,0	1,94	4,7,11
80 HX	¹⁴	25,400	1	15,75	24,28	24,49	15,88	7,92	-	24,1	5,4	37,0	1,92	75,6	3,04	4,7,111
100 HX	¹⁴	31,750	1 ¼	18,90	29,10	29,30	19,05	9,53	-	30,1	6,1	44,0	2,77	113,4	4,25	4,7,111

¹ with straight side plates ¹⁴ Type series HX with reinforced plates and pins made of quenched and tempered steel

For details on orders and enquiries see page 131. Sprockets on request.

Connecting links: According to ISO (...)



No. 4 (B)
Inner link



No. 7 (A)
Outer link
(to be riveted)



No. 11 (E)
Spring clip
connecting link



No. 111 (S)
Connecting link
with cottered pin

Type 1

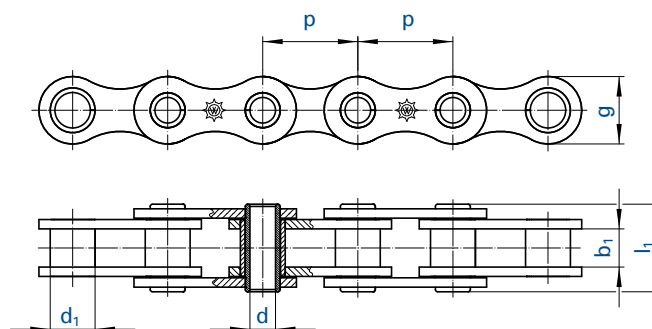

Type 2

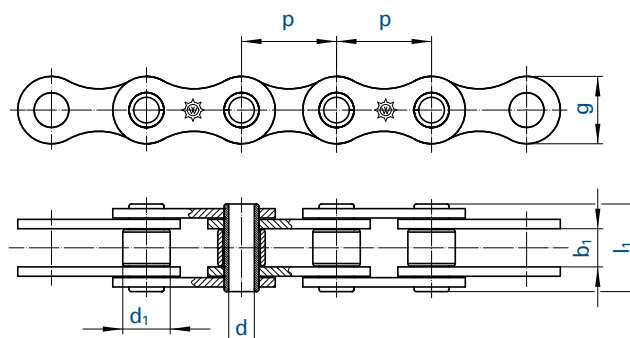

Type 3

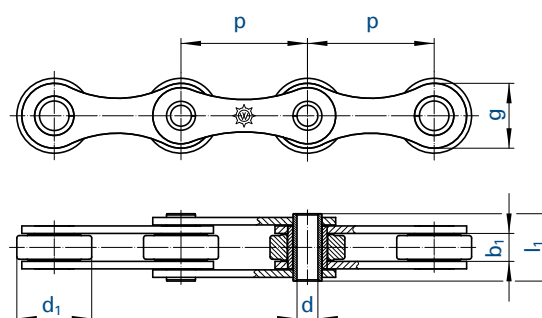

Chain		Pitch		Inner width	Roller (Bushing) Ø	Hollow pin		Plate height	Type	Bearing area	Breaking load	Weight
⚙		p		b ₁	d ₁	Bore Ø	Width	g		f	F _B	q
No.	Ind.	mm	inch	min.	max.	d +0,1	l ₁	max.		cm ²	kN min.	kg/m ≈
01105		12,700	1/2	3,30	7,75	4,2	10,2	10,5	2	0,14	10,0	0,34
01462		12,700	1/2	7,75	8,51	4,0	17,0	12,2	1	0,68	10,0	0,65
01463		12,700	1/2	9,50	8,51	4,0	19,0	11,8	2	0,20	14,0	0,68
01500		15,875	5/8	6,50	10,16	5,0	17,0	14,7	2	0,28	15,0	0,74
01501		15,875	5/8	9,50	10,16	5,0	20,0	14,7	2	0,28	15,0	0,83
01513		19,050	3/4	11,70	12,07	5,0	22,5	16,1	2	0,30	25,0	1,07
01589		38,100	1 1/2	15,20	18,00	10,2	34,5	28,0	1	2,28	45,0	2,62
01598	^{1,3}	50,000	-	15,00	26,00	14,4	35,6	40,0	1	4,20	100,0	4,10
01650	^{4,5}	50,800	2	11,00	30,00	8,2	27,0	26,0	3	1,94	50,0	2,15
01650RF	^{4,5,6}	50,800	2	11,00	30,00	8,2	27,0	26,0	3	1,94	32,0	2,15

Electrogalvanised or nickel-plated chains on request. In this case chains may only have 80 % of the tensile strength.

¹ with straight side plates ³ also supplied with small rollers 32 mm Ø (Type 3) ⁴ also with plastic rollers ⁵ support rollers ⁶ made of stainless and acid resistant steel W.-No. 1.4301

For details on orders and enquiries see page 131. Sprockets on request.
Information on the selection of chain sizes and drives as of page 118.

Hollow pin chains are to be connected by means of outer links (pin links). For the chains No. 01597 and No. 01598 straight connecting links with Seeger circlip ring can be supplied.

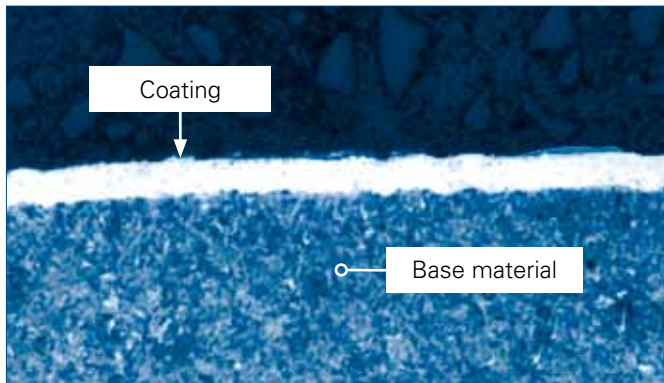

Cross-section polish of coated chain pin

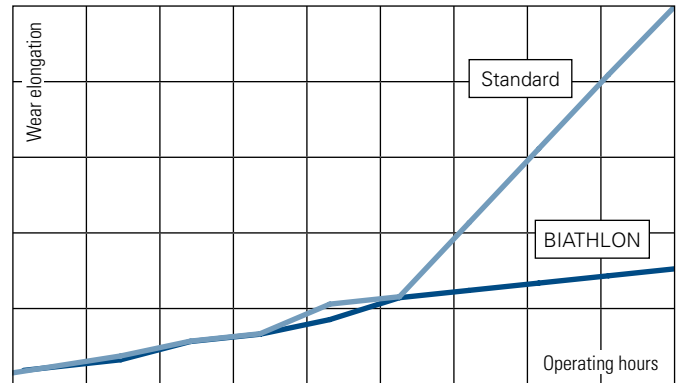

Wear diagram

BIATHLON

Roller chain (type GL) with POM clip including TPU overlay

Range of application

The high-performance chain BIATHLON shows its advantages wherever the use of standard roller chains is not economical due to difficult maintenance conditions.

The special coating of chain pins and rollers allows for excellent dry-running operation characteristics and thus makes this chain particularly resistant against phases without sufficient relubrication. The extended wear life increases the availability of machines and equipment.

The BIATHLON chain can also be supplied in a corrosion-protected design (see page 26).

Coating

The special surface coating of the BIATHLON chain guarantees a high resistance against abrasive and adhesive wear even in case of poor lubrication. Thus fretting will be avoided to a large extent. Due to special finishing treatment procedures the surface has an optimal ductility despite its hardness.

The coating process features a reproducible layer thickness as well as an extraordinary outline constancy and an even layer thickness on the chain components.

Technical features

- Coated chain pins
- Coated rollers
- Special long-term lubricants

Benefits for application

- Particularly efficient
- Dry-running operation characteristics in case of deficient lubrication
- Corrosion-protection on request



Simplex chains

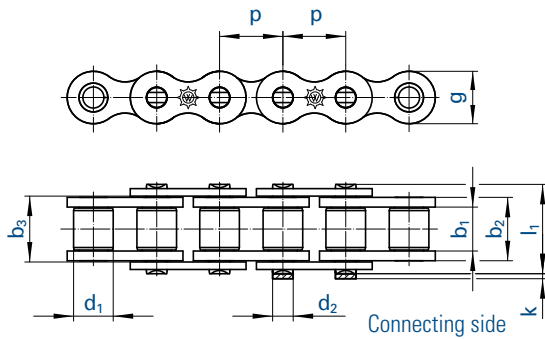

Simplex chains (type series GL)

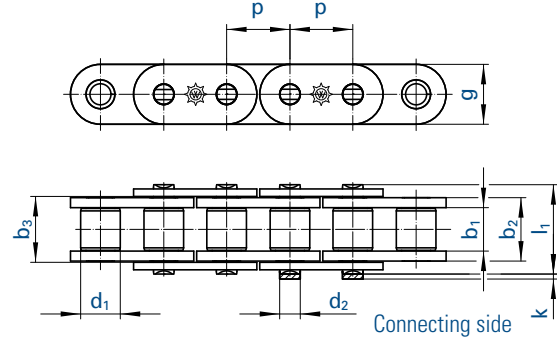

Duplex chains

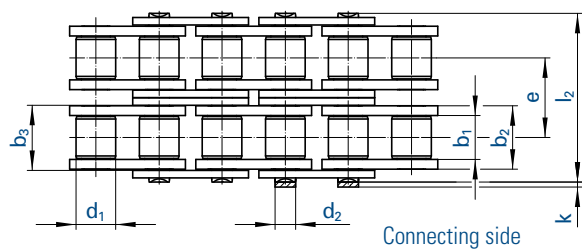

Triplex chains

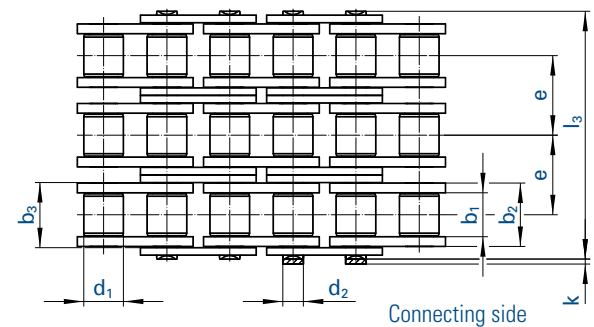

Chain according to ISO 606		Pitch		Inner width	Inner link width	Outer plate width	Roller Ø	Pin Ø	Transverse pitch	Plate height	Projection over connecting link	Width over pin	Bearing area	Breaking load	Weight	Connecting links
⚙		p		b ₁ min.	b ₂ max.	b ₃ min.	d ₁ max.	d ₂ max.	e	g max.	k max.	l max.	f	F _B min.	q ≈	No.
No.	Ind.	mm	inch	mm	mm	mm	mm	mm	mm	mm	mm	mm	cm ²	kN	kg/m	No.
08 B-1 BI		12,700	1/2	7,75	11,30	11,43	8,51	4,45	-	11,8	3,9	17,0	0,50	18,6	0,70	11,12,15
10 B-1 BI		15,875	5/8	9,65	13,28	13,41	10,16	5,08	-	14,7	4,1	19,6	0,67	27,0	0,91	11,12,15
12 B-1 BI		19,050	3/4	11,68	15,62	15,75	12,07	5,72	-	16,1	4,6	22,7	0,89	31,0	1,18	11,12,15
16 B-1 BI		25,400	1	17,02	25,40	25,60	15,88	8,28	-	21,0	5,4	36,1	2,10	72,0	2,68	11,111,12
20 B-1 BI		31,750	1 1/4	19,56	29,00	29,20	19,05	10,19	-	26,4	6,1	43,2	2,96	105,0	3,50	111,12
24 B-1 BI		38,100	1 1/2	25,40	37,90	38,20	25,40	14,63	-	33,4	6,6	53,4	5,54	180,0	6,80	111,12
08 B-2 BI		12,700	1/2	7,75	11,30	11,43	8,51	4,45	13,92	11,8	3,9	31,0	1,01	37,0	1,36	11,12,15
10 B-2 BI		15,875	5/8	9,65	13,28	13,41	10,16	5,08	16,59	14,7	4,1	36,2	1,34	54,0	1,82	11,12,15
12 B-2 BI		19,050	3/4	11,68	15,62	15,75	12,07	5,72	19,46	16,1	4,6	42,2	1,79	63,0	2,38	11,12,15
16 B-2 BI		25,400	1	17,02	25,40	25,60	15,88	8,28	31,88	21,0	5,4	68,0	4,21	140,0	5,30	11,111,12
20 B-2 BI		31,750	1 1/4	19,56	25,40	29,20	19,05	10,19	36,45	26,4	6,1	79,0	5,91	210,0	7,30	111,12
24 B-2 BI		38,100	1 1/2	25,40	37,90	38,20	25,40	14,63	48,36	33,4	6,6	101,0	11,09	360,0	13,40	111,12
08 B-3 BI		12,700	1/2	7,75	11,30	11,43	8,51	4,45	13,92	11,8	3,9	44,9	1,51	56,0	2,01	11,12,15
10 B-3 BI		15,875	5/8	9,65	13,28	13,41	10,16	5,08	16,59	14,7	4,1	52,8	2,02	80,0	2,70	11,12,15
12 B-3 BI		19,050	3/4	11,68	15,62	15,75	12,07	5,72	19,46	16,1	4,6	61,7	2,68	94,0	3,12	11,12,15
16 B-3 BI		25,400	1	17,02	25,40	25,60	15,88	8,28	31,88	21,0	5,4	99,9	6,31	211,0	7,50	11,111,12
20 B-3 BI		31,750	1 1/4	19,56	29,00	29,20	19,05	10,19	36,45	26,4	6,1	116,0	8,87	300,0	10,60	111,12
24 B-3 BI		38,100	1 1/2	25,40	37,90	38,20	25,40	14,63	48,36	33,4	6,6	150,0	16,63	523,0	20,00	111,12

Can also be supplied with attachments and straight plates (type series GL).
Chains 16-B GLS available with plate height g = 21 mm (max.) and as type series GL with g = 24 mm (max.).
Standard sprockets can be used for these chains.

Connecting links: According to ISO (...)



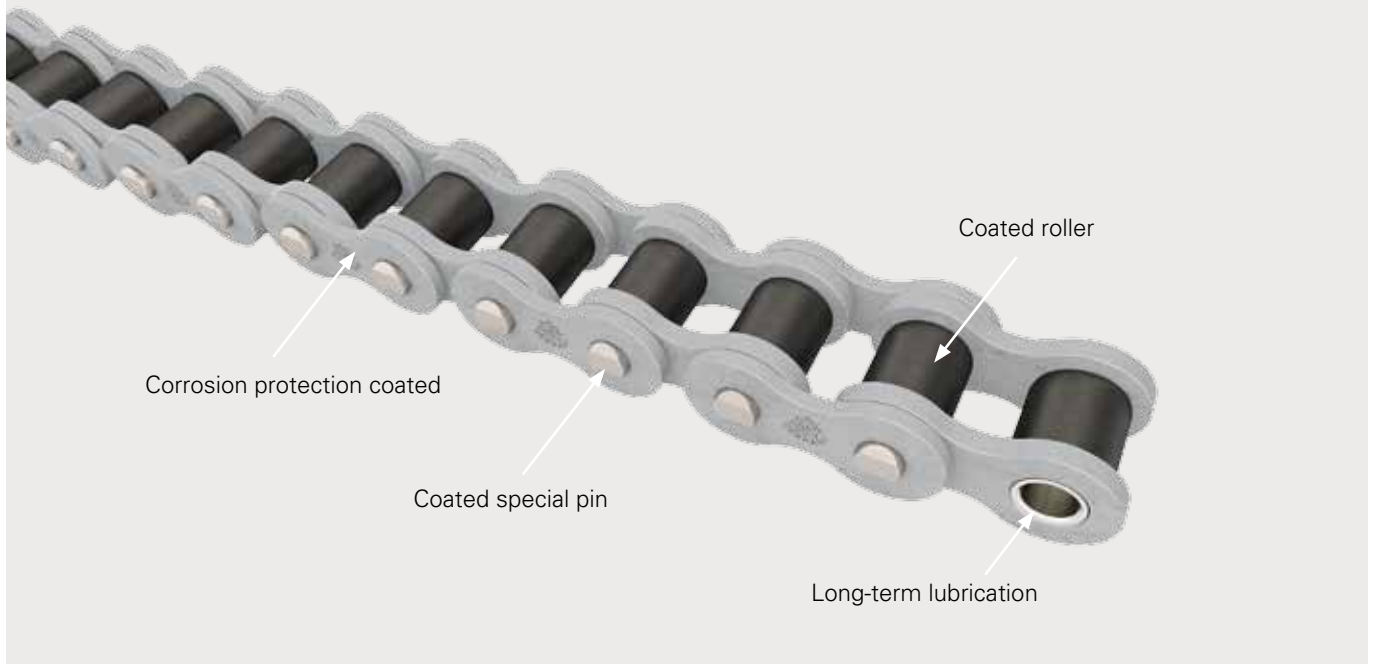

BIATHLON KS

Highest corrosion resistance in its class

Application areas

In a number of industrial sectors, e.g. in the food processing or in the packing industry, humid ambient conditions frequently impede relubrication of the chains. The annoying consequence is considerable chain wear resulting in too short change intervals and thus in unnecessarily high maintenance costs. In this case the combination of low maintenance requirements and high corrosion resistance with carbon steel chains makes double sense.

Proven quality

The KS type BIATHLON high performance chain has the highest corrosion resistance in its class. On the basis of the standard BIATHLON chain with its already excellent wear protection, environmentally-friendly corrosion protection material of the highest quality is additionally applied when manufacturing the KS type BIATHLON chain. In salt spray tests the BIATHLON KS proved to be corrosion resistant for a period of more than 1000 hours.

Under the same test conditions comparisons showed significant corrosion on competing chains after approx. 200 hours.

This long-life cycle has been achieved by combining different surface technologies that do not interact negatively with each other.

Technical features

- Coated chain pins and bushings
- Coated rollers
- Coated plates
- Special long-term lubricants

Benefits for application

- Particularly efficient
- Dry-running operation characteristics in case of deficient lubrication
- High-tech corrosion protection
- RoHS compliance due to non-use of hexavalent chromium
- Temperatures from -30°C to +150°C



Simplex chains

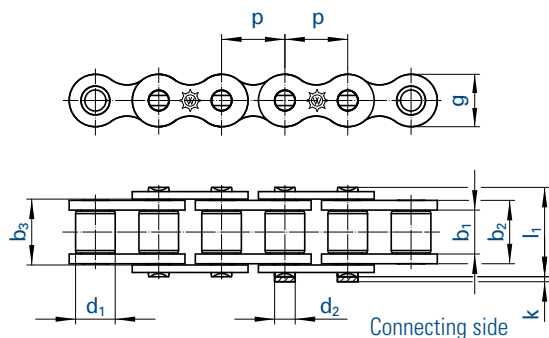

Simplex chains (type series GL)

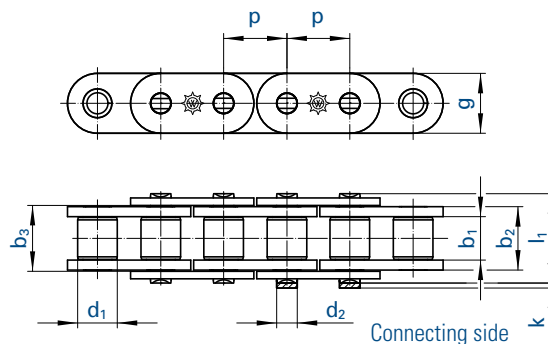

Duplex chains

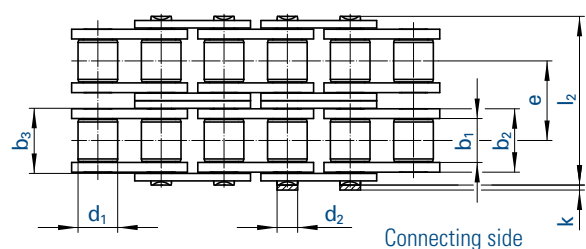

Triplex chains

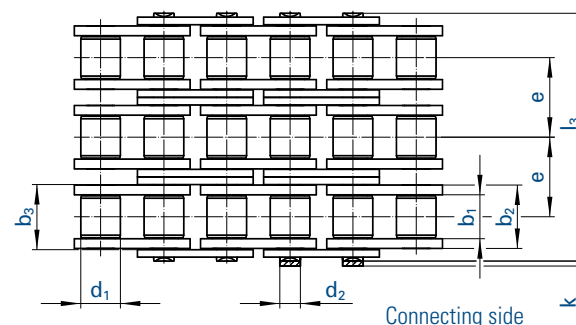

Chain according to ISO 606		Pitch		Inner width	Inner link width	Outer plate width	Roller Ø	Pin Ø	Transverse pitch	Plate height	Projection over connecting link	Width over pin	Bearing area	Breaking load	Weight	Connecting links
⚙		p		b ₁ min.	b ₂ max.	b ₃ min.	d ₁ max.	d ₂ max.	e	g max.	k max.	l max.	f	F _B min.	q ≈	No.
No.	Ind.	mm	inch	mm	mm	mm	mm	mm	mm	mm	mm	mm	cm ²	kN	kg/m	No.
08 B-1 BI KS		12,700	1/2	7,75	11,30	11,43	8,51	4,45	-	11,8	3,9	17,0	0,50	18,6	0,70	11,12,15
10 B-1 BI KS		15,875	5/8	9,65	13,28	13,41	10,16	5,08	-	14,7	4,1	19,6	0,67	27,0	0,91	11,12,15
12 B-1 BI KS		19,050	3/4	11,68	15,62	15,75	12,07	5,72	-	16,1	4,6	22,7	0,89	31,0	1,18	11,12,15
16 B-1 BI KS		25,400	1	17,02	25,40	25,60	15,88	8,28	-	21,0	5,4	36,1	2,10	72,0	2,68	11,111,12
20 B-1 BI KS		31,750	1 1/4	19,56	29,00	29,20	19,05	10,19	-	26,4	6,1	43,2	2,96	105,0	3,50	111,12
24 B-1 BI KS		38,100	1 1/2	25,40	37,90	38,20	25,40	14,63	-	33,4	6,6	53,4	5,54	180,0	6,80	111,12
08 B-2 BI KS		12,700	1/2	7,75	11,30	11,43	8,51	4,45	13,92	11,8	3,9	31,0	1,01	37,0	1,36	11,12,15
10 B-2 BI KS		15,875	5/8	9,65	13,28	13,41	10,16	5,08	16,59	14,7	4,1	36,2	1,34	54,0	1,82	11,12,15
12 B-2 BI KS		19,050	3/4	11,68	15,62	15,75	12,07	5,72	19,46	16,1	4,6	42,2	1,79	63,0	2,38	11,12,15
16 B-2 BI KS		25,400	1	17,02	25,40	25,60	15,88	8,28	31,88	21,0	5,4	68,0	4,21	140,0	5,30	11,111,12
20 B-2 BI KS		31,750	1 1/4	19,56	29,00	29,20	19,05	10,19	36,45	26,4	6,1	79,0	5,91	210,0	7,30	111,12
24 B-2 BI KS		38,100	1 1/2	25,40	37,90	38,20	25,40	14,63	48,36	33,4	6,6	101,0	11,09	360,0	13,40	111,12
08 B-3 BI KS		12,700	1/2	7,75	11,30	11,43	8,51	4,45	13,92	11,8	3,9	44,9	1,51	56,0	2,01	11,12,15
10 B-3 BI KS		15,875	5/8	9,65	13,28	13,41	10,16	5,08	16,59	14,7	4,1	52,8	2,02	80,0	2,70	11,12,15
12 B-3 BI KS		19,050	3/4	11,68	15,62	15,75	12,07	5,72	19,46	16,1	4,6	61,7	2,68	94,0	3,12	11,12,15
16 B-3 BI KS		25,400	1	17,02	25,40	25,60	15,88	8,28	31,88	21,0	5,4	99,9	6,31	211,0	7,50	11,111,12
20 B-3 BI KS		31,750	1 1/4	19,56	29,00	29,20	19,05	10,19	36,45	26,4	6,1	116,0	8,87	300,0	10,60	111,12
24 B-3 BI KS		38,100	1 1/2	25,40	37,90	38,20	25,40	14,63	48,36	33,4	6,6	150,0	16,63	523,0	20,00	111,12

Can also be supplied with attachments and straight plates (type series GL).
Chains 16-B GLS available with plate height g = 21 mm (max.) and as type series GL with g = 24 mm (max.).
Standard sprockets can be used for these chains.

Connecting links: According to ISO (...)





TRIATHLON HT

Maintenance-free and high load bearing up to 200°C

The TRIATHLON HT high-performance chain has a high load capacity for temperatures up to 200°C, even without additional lubricants, and is extremely wear-resistant.

Whether with minimal surface lubrication to protect the sprockets or completely free of lubrication for highly sensitive applications, the TRIATHLON HT sets new standards with perfectly coordinated materials, coated pins, special coated rollers and also through its innovative high-tech polymer bushings in numerous application areas.

Designed for difficult applications

In many production processes, the combination of high temperatures and sensitive components present specific requirements for the chains.

In the automotive industry, hoisting and conveyor chains thus reduce scrap in the coating process by avoiding unwanted paint wetting with lubricant residues, in contrast to conventionally lubricated chains. In the electrical industry, chains have to be complete dry without lubrication to avoid chemical reactions e.g. in casting resins.

Proven in practice

The durability of the TRIATHLON HT is achieved through unique material combinations with special coated pins and polymer bearings. Many renowned companies have recognised the benefits of the TRIATHLON HT and are already demonstrating the success of our high-performance chains under high loads and temperatures, which require uncompromised durability and wear resistance.

Technical features

- Coated bushings with high-tech polymer inserts
- Coated pin chains
- Coated rollers

Benefits for application

- Highly resilient, low friction chain joints
- No relubrication required
- Lubricant-free for chain speeds up to 2.5 m/s
- Temperatures from -30°C to +200°C

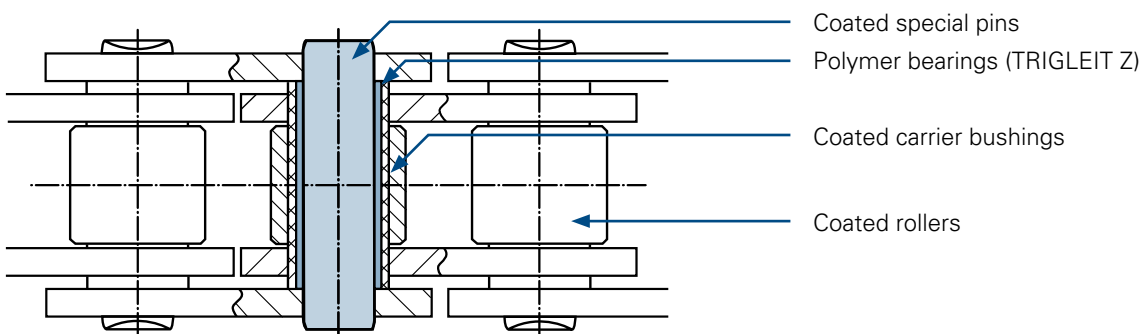



Simplex chains

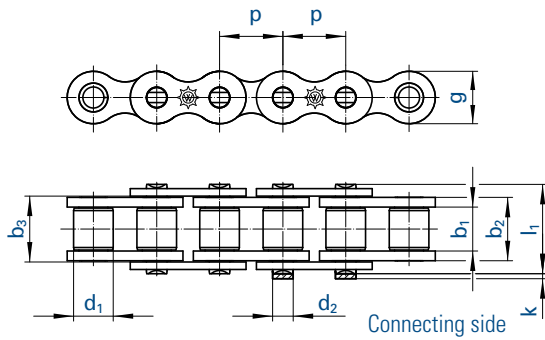

Simplex chains (type series GL)

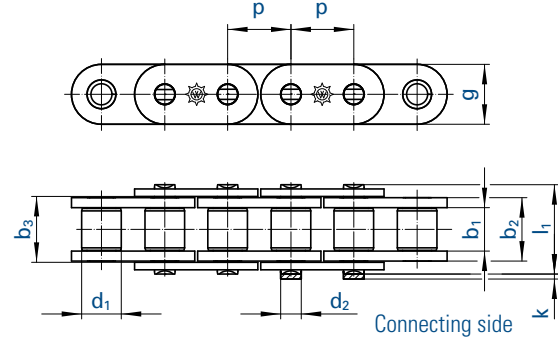

Duplex chains

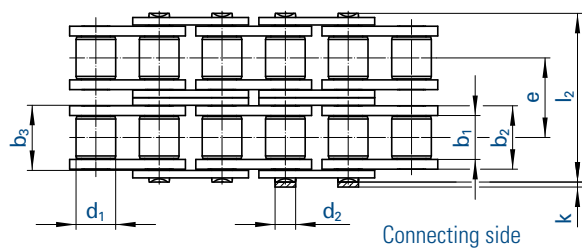

Triplex chains

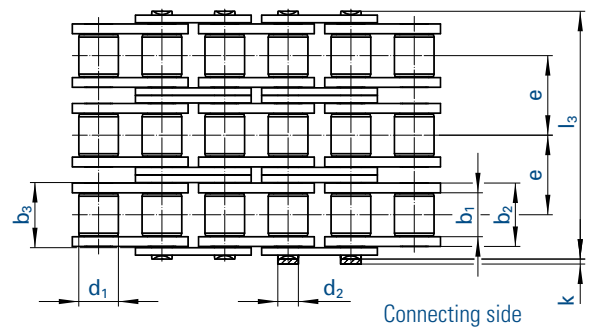

Chain according to ISO 606		Pitch		Inner width	Inner link width	Outer plate width	Roller Ø	Pin Ø	Transverse pitch	Plate height	Projection over connecting link	Width over pin	Bearing area	Breaking load	Weight	Connecting links
⚙		p		b ₁ min.	b ₂ max.	b ₃ min.	d ₁ max.	d ₂ max.	e	g max.	k max.	l max.	f	F _B min.	q ≈	No.
No.	Ind.	mm	inch	mm	mm	mm	mm	mm	mm	mm	mm	mm	cm ²	kN	kg/m	No.
08 B-1 TR HT		12,700	1/2	7,75	11,30	11,43	8,51	4,45	-	11,8	3,9	17,0	0,50	18,6	0,70	11,12,15
10 B-1 TR HT		15,875	5/8	9,65	13,28	13,41	10,16	5,08	-	14,7	4,1	19,6	0,67	27,0	0,91	11,12,15
12 B-1 TR HT		19,050	3/4	11,68	15,62	15,75	12,07	5,72	-	16,1	4,6	22,7	0,89	31,0	1,18	11,12,15
16 B-1 TR HT		25,400	1	17,02	25,40	25,60	15,88	8,28	-	21,0	5,4	36,1	2,10	72,0	2,68	11,111,12
20 B-1 TR HT		31,750	1 1/4	19,56	29,00	29,20	19,05	10,19	-	26,4	6,1	43,2	2,96	105,0	3,50	111,12
24 B-1 TR HT		38,100	1 1/2	25,40	37,90	38,20	25,40	14,63	-	33,4	6,6	53,4	5,54	180,0	6,80	111,12
08 B-2 TR HT		12,700	1/2	7,75	11,30	11,43	8,51	4,45	13,92	11,8	3,9	31,0	1,01	37,0	1,36	11,12,15
10 B-2 TR HT		15,875	5/8	9,65	13,28	13,41	10,16	5,08	16,59	14,7	4,1	36,2	1,34	54,0	1,82	11,12,15
12 B-2 TR HT		19,050	3/4	11,68	15,62	15,75	12,07	5,72	19,46	16,1	4,6	42,2	1,79	63,0	2,38	11,12,15
16 B-2 TR HT		25,400	1	17,02	25,40	25,60	15,88	8,28	31,88	21,0	5,4	68,0	4,21	140,0	5,30	11,111,12
20 B-2 TR HT		31,750	1 1/4	19,56	25,40	29,20	19,05	10,19	36,45	26,4	6,1	79,0	5,91	210,0	7,30	111,12
24 B-2 TR HT		38,100	1 1/2	25,40	37,90	38,20	25,40	14,63	48,36	33,4	6,6	101,0	11,09	360,0	13,40	111,12
08 B-3 TR HT		12,700	1/2	7,75	11,30	11,43	8,51	4,45	13,92	11,8	3,9	44,9	1,51	56,0	2,01	11,12,15
10 B-3 TR HT		15,875	5/8	9,65	13,28	13,41	10,16	5,08	16,59	14,7	4,1	52,8	2,02	80,0	2,70	11,12,15
12 B-3 TR HT		19,050	3/4	11,68	15,62	15,75	12,07	5,72	19,46	16,1	4,6	61,7	2,68	94,0	3,12	11,12,15
16 B-3 TR HT		25,400	1	17,02	25,40	25,60	15,88	8,28	31,88	21,0	5,4	99,9	6,31	211,0	7,50	11,111,12
20 B-3 TR HT		31,750	1 1/4	19,56	29,00	29,20	19,05	10,19	36,45	26,4	6,1	116,0	8,87	300,0	10,60	111,12
24 B-3 TR HT		38,100	1 1/2	25,40	37,90	38,20	25,40	14,63	48,36	33,4	6,6	150,0	16,63	523,0	20,00	111,12

Other chain sizes available on request. Can also be supplied with attachments and straight plates (type series GL).
Chains 16-B GLS available with plate height g = 21 mm (max.) and as type series GL with g = 24 mm (max.)

Standard sprockets can be used for these chains.

Connecting links: According to ISO (...)





TRIATHLON KS

Corrosion resistant and lubrication-free for highly sensitive production processes

With TRIATHLON KS, we expand our leadership role for maintenance-free chains that do not require lubrication. Especially in sensitive production processes, e.g. in the food, cosmetics and packaging industry, it proves to be a real all-rounder due to its high load bearing carbon steels, environmentally friendly corrosion protection and our tried and proved TRIGLEIT FDA polymer bushings.

Application areas

The TRIATHLON KS chain is ideally suited for application in large systems, intermittent operation and humid ambient conditions. Thanks to its high durability and wear resistance without the need for relubrication, its application is particularly economic in these areas.

Corrosion protection at its best

Just like BIATHLON KS, which has been providing excellent service in many years of practical use, the TRIATHLON KS features environmentally friendly corrosion protection which has proved to be highly resistant for a period of more than 1,000 hours in salt spray tests. Whether with minimal H1 surface lubrication to protect the sprockets or completely free of lubrication, the TRIATHLON KS sets new standards in terms of loa-

ding capacity, corrosion resistance, durability and wear resistance with perfectly coordinated materials, functional layers and innovative TRIGLEIT FDA polymer bushings.

Technical features

- Coated bushings with TRIGLEIT FDA inserts
- Coated pins and plates
- Rolls made of corrosion resistant steel with maximum ductility

Benefits for application

- High-tech corrosion protection
- RoHS compliance due to non-use of hexavalent chromium
- Highly resilient, low friction chain joints
- No relubrication required
- Lubricant-free for chain speeds up to 2.5 m/s
- Temperatures from -30°C to + 150°C (up to + 200°C on request)

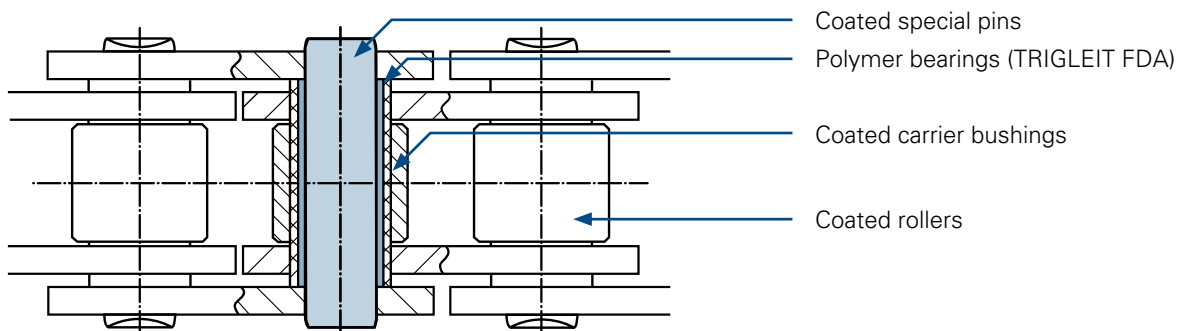



Simplex chains

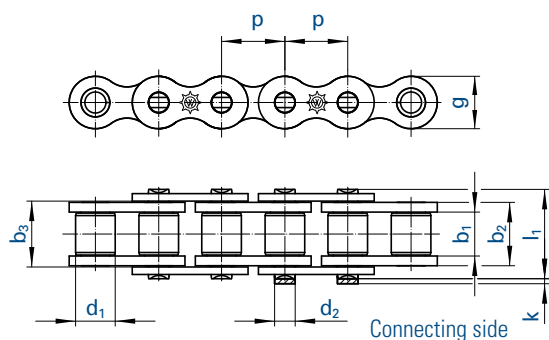

Simplex chains (type series GL)

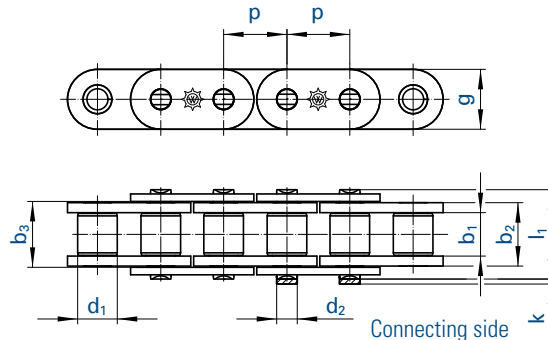

Duplex chains

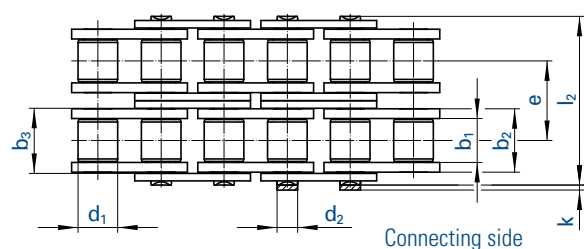

Triplex chains

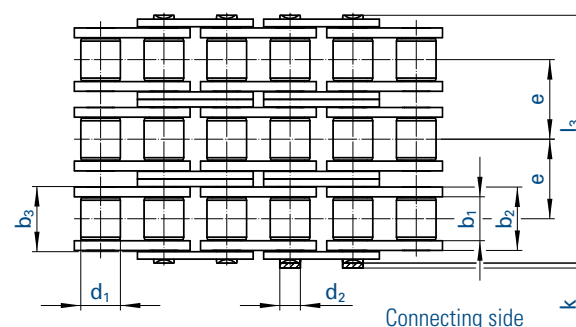

Chain according to ISO 606		Pitch		Inner width	Inner link width	Outer plate width	Roller Ø	Pin Ø	Transverse pitch	Plate height	Projection over connecting link	Width over pin	Bearing area	Breaking load	Weight	Connecting links
⚙		p		b ₁ min.	b ₂ max.	b ₃ min.	d ₁ max.	d ₂ max.	e	g max.	k max.	l max.	f	F _B min.	q ≈	No.
No.	Ind.	mm	inch	mm	mm	mm	mm	mm	mm	mm	mm	mm	cm ²	kN	kg/m	No.
08 B-1 TR KS		12,700	1/2	7,75	11,30	11,43	8,51	4,45	-	11,8	3,9	17,0	0,50	18,6	0,70	11,12,15
10 B-1 TR KS		15,875	5/8	9,65	13,28	13,41	10,16	5,08	-	14,7	4,1	19,6	0,67	27,0	0,91	11,12,15
12 B-1 TR KS		19,050	3/4	11,68	15,62	15,75	12,07	5,72	-	16,1	4,6	22,7	0,89	31,0	1,18	11,12,15
16 B-1 TR KS		25,400	1	17,02	25,40	25,60	15,88	8,28	-	21,0	5,4	36,1	2,10	72,0	2,68	11,111,12
20 B-1 TR KS		31,750	1 1/4	19,56	29,00	29,20	19,05	10,19	-	26,4	6,1	43,2	2,96	105,0	3,50	111,12
24 B-1 TR KS		38,100	1 1/2	25,40	37,90	38,20	25,40	14,63	-	33,4	6,6	53,4	5,54	180,0	6,80	111,12
08 B-2 TR KS		12,700	1/2	7,75	11,30	11,43	8,51	4,45	13,92	11,8	3,9	31,0	1,01	37,0	1,36	11,12,15
10 B-2 TR KS		15,875	5/8	9,65	13,28	13,41	10,16	5,08	16,59	14,7	4,1	36,2	1,34	54,0	1,82	11,12,15
12 B-2 TR KS		19,050	3/4	11,68	15,62	15,75	12,07	5,72	19,46	16,1	4,6	42,2	1,79	63,0	2,38	11,12,15
16 B-2 TR KS		25,400	1	17,02	25,40	25,60	15,88	8,28	31,88	21,0	5,4	68,0	4,21	140,0	5,30	11,111,12
20 B-2 TR KS		31,750	1 1/4	19,56	25,40	29,20	19,05	10,19	36,45	26,4	6,1	79,0	5,91	210,0	7,30	111,12
24 B-2 TR KS		38,100	1 1/2	25,40	37,90	38,20	25,40	14,63	48,36	33,4	6,6	101,0	11,09	360,0	13,40	111,12
08 B-3 TR KS		12,700	1/2	7,75	11,30	11,43	8,51	4,45	13,92	11,8	3,9	44,9	1,51	56,0	2,01	11,12,15
10 B-3 TR KS		15,875	5/8	9,65	13,28	13,41	10,16	5,08	16,59	14,7	4,1	52,8	2,02	80,0	2,70	11,12,15
12 B-3 TR KS		19,050	3/4	11,68	15,62	15,75	12,07	5,72	19,46	16,1	4,6	61,7	2,68	94,0	3,12	11,12,15
16 B-3 TR KS		25,400	1	17,02	25,40	25,60	15,88	8,28	31,88	21,0	5,4	99,9	6,31	211,0	7,50	11,111,12
20 B-3 TR KS		31,750	1 1/4	19,56	29,00	29,20	19,05	10,19	36,45	26,4	6,1	116,0	8,87	300,0	10,60	111,12
24 B-3 TR KS		38,100	1 1/2	25,40	37,90	38,20	25,40	14,63	48,36	33,4	6,6	150,0	16,63	523,0	20,00	111,12

Other chain sizes available on request. Can also be supplied with attachments and straight plates (type series GL).
Chains 16-B GLS available with plate height g = 21 mm (max.) and as type series GL with g = 24 mm (max.)

Standard sprockets can be used for these chains.

Connecting links: According to ISO (...)



No. 4 (B)
Inner link



No. 7 (A)
Outer link
(to be riveted)



No. 11 (E)
Spring clip
connecting link



No. 111 (S)
Connecting link
with cottered pin



No. 12 (L)
Single
cranked link



No. 15 (C)
Double
cranked link



MARATHON

Long distance chain that needs no relubrication

Apart from availability, operational safety and reliability, the fact that components are maintenance-free is getting more and more important in machine and plant construction. The use of MARATHON chains always makes sense where relubrication of roller chains is either not possible or not desired, but where, nevertheless, a long life cycle is required.

Technical features

- Up to 35 times longer wear life in comparison with other standard roller chains without lubrication
- Up to 5 times longer wear life than other maintenance-free chains
- No relubrication required
- Clean application with no soiling of machinery and transported goods
- Joint bushings made with a new type of sintered metal with high strength treated with a special lubricant
- High-performance bearing joints
- Bushings longer than the width of the chain link with sliding contact to the outer plate
- The pins forming the joints with these bushings are made of alloyed hardened steel and are treated with a special coating. The resulting high-wearing coat guarantees an excellent sliding performance.
- Same tensile strength as with WIPPERMANN standard chains
- All MARATHON chains fit standard sprockets

Application areas

- Temperatures from 0°C to +100°C
- With special lubrication from -30°C to +250°C (after consultation)
- Speeds of up to $v = 150$ m/min.
- Electrical industry
- Production of printed circuit boards (PCBs)
- Television industry
- Packing industry
- Paper processing
- Printing industry
- Bookbinding industry
- Textile industry
- Automotive industry
- All systems where relubrication is either not wanted, problematic or not possible at all.

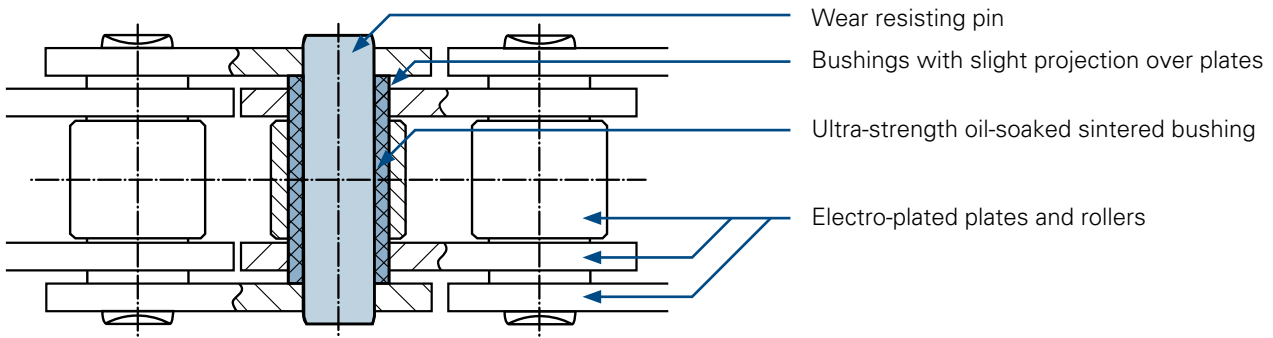

Force projection diagram

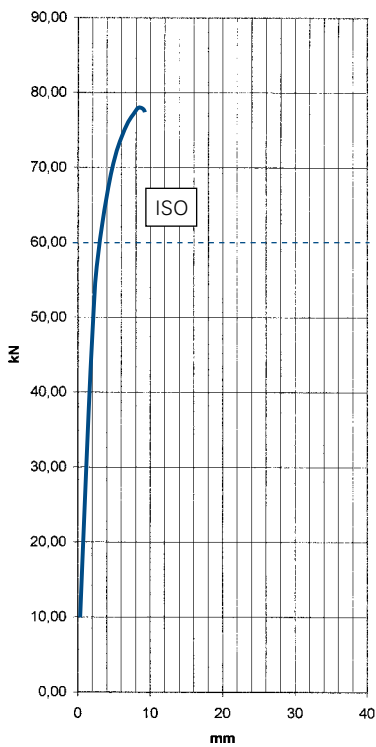

Type of test: Tensile test
Object: 548 MARATHON chain
Test length: 5 links

Breaking load: 78,000 N
Breaking point: Pins

Results of long-term wear tests

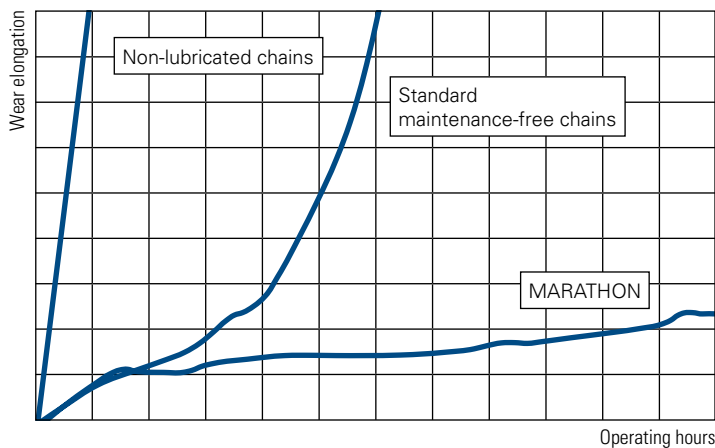



Simplex chains

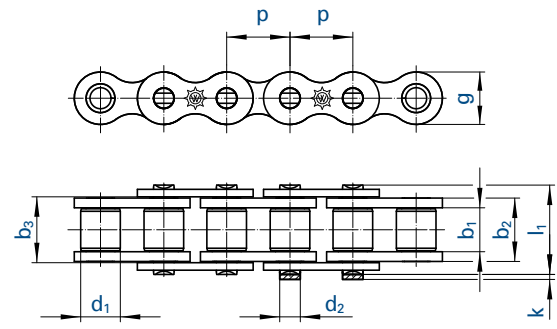

Connecting side

Duplex chains

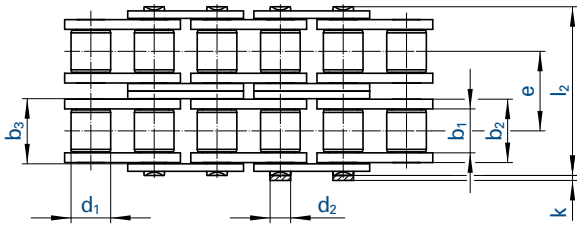

Connecting side

Triplex chains

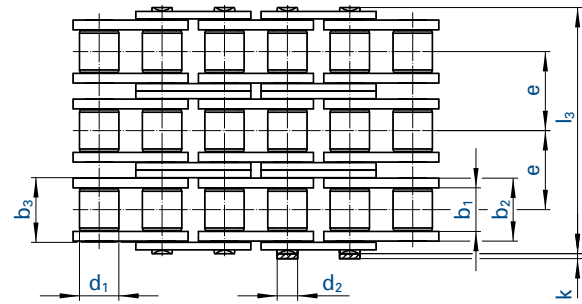

Connecting side

Chain according to ISO 606		Pitch		Inner width	Inner link width	Outer plate width	Roller Ø	Pin Ø	Transverse pitch	Plate height	Projection over connecting link	Width over pin	Bearing area	Breaking load	Weight	Connecting links
⚙		p		b ₁ min.	b ₂ max.	b ₃ min.	d ₁ max.	d ₂ max.	e	g max.	k max.	l max.	f	F _B min.	q ≈	No.
No.	Ind.	mm	inch	mm	mm	mm	mm	mm	mm	mm	mm	mm	cm ²	kN	kg/m	No.
06 B-1 MA	¹	9,525	3/8	5,72	8,53	8,66	6,35	3,28	-	8,2	3,3	13,5	0,28	9,6	0,41	11,12,15
08 B-1 MA		12,700	1/2	7,75	11,30	11,43	8,51	4,45	-	11,8	3,9	17,0	0,50	18,6	0,70	11,12,15
10 B-1 MA		15,875	5/8	9,65	13,28	13,41	10,16	5,08	-	14,7	4,1	19,6	0,67	27,0	0,91	11,12,15
12 B-1 MA		19,050	3/4	11,68	15,62	15,75	12,07	5,72	-	16,1	4,6	22,7	0,89	31,0	1,18	11,12,15
16 B-1 MA		25,400	1	17,02	25,40	25,60	15,88	8,28	-	21,0	5,4	36,1	2,10	72,0	2,68	11,111,12
552 MA		30,000	-	17,02	25,40	-	15,88	8,28	-	21,0	5,4	36,1	2,10	72,0	2,50	11,111,12
20 B-1 MA		31,750	1 1/4	19,56	29,00	29,20	19,05	10,19	-	26,4	6,1	43,2	2,96	105,0	3,50	111,12
24 B-1 MA		38,100	1 1/2	25,40	37,90	38,20	25,40	14,63	-	33,4	6,6	53,4	5,54	180,0	6,80	111,12
06 B-2 MA	¹	9,525	3/8	5,72	8,53	8,66	6,35	3,28	10,24	8,2	3,3	23,8	0,56	17,4	0,86	11,12,15
08 B-2 MA		12,700	1/2	7,75	11,30	11,43	8,51	4,45	13,92	11,8	3,9	31,0	1,01	37,0	1,36	11,12,15
10 B-2 MA		15,875	5/8	9,65	13,28	13,41	10,16	5,08	16,59	14,7	4,1	36,2	1,34	54,0	1,82	11,12,15
12 B-2 MA		19,050	3/4	11,68	15,62	15,75	12,07	5,72	19,46	16,1	4,6	42,2	1,79	63,0	2,38	11,12,15
16 B-2 MA		25,400	1	17,02	25,40	25,60	15,88	8,28	31,88	21,0	5,4	68,0	4,21	140,0	5,30	11,111,12
20 B-2 MA		31,750	1 1/4	19,56	25,40	29,20	19,05	10,19	36,45	26,4	6,1	79,0	5,91	210,0	7,30	111, 12
24 B-2 MA		38,100	1 1/2	25,40	37,90	38,20	25,40	14,63	48,36	33,4	6,6	101,0	11,09	360,0	13,40	111, 12
06 B-3 MA	¹	9,525	3/8	5,72	8,53	8,66	6,35	3,28	10,24	8,2	3,3	34,0	0,81	24,9	1,30	11,12,15
08 B-3 MA		12,700	1/2	7,75	11,30	11,43	8,51	4,45	13,92	11,8	3,9	44,9	1,51	56,0	2,01	11,12,15
10 B-3 MA		15,875	5/8	9,65	13,28	13,41	10,16	5,08	16,59	14,7	4,1	52,8	2,02	80,0	2,70	11,12,15
12 B-3 MA		19,050	3/4	11,68	15,62	15,75	12,07	5,72	19,46	16,1	4,6	61,7	2,68	94,0	3,12	11,12,15
16 B-3 MA		25,400	1	17,02	25,40	25,60	15,88	8,28	31,88	21,0	5,4	99,9	6,31	211,0	7,50	11,111,12
20 B-3 MA		31,750	1 1/4	19,56	29,00	29,20	19,05	10,19	36,45	26,4	6,1	116,0	8,87	300,0	10,60	111,12
24 B-3 MA		38,100	1 1/2	25,40	37,90	38,20	25,40	14,63	48,36	33,4	6,6	150,0	16,63	523,0	20,00	111,12

¹ with straight side plates

Standard sprockets can be used for these chains.



Simplex chains

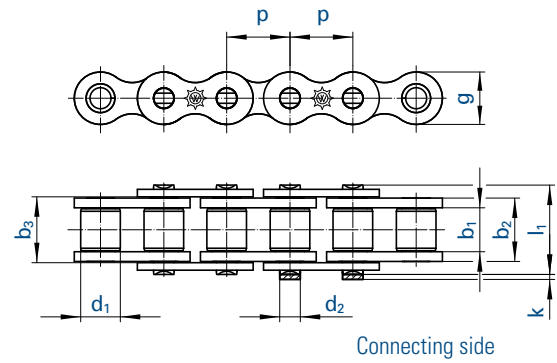

Duplex chains

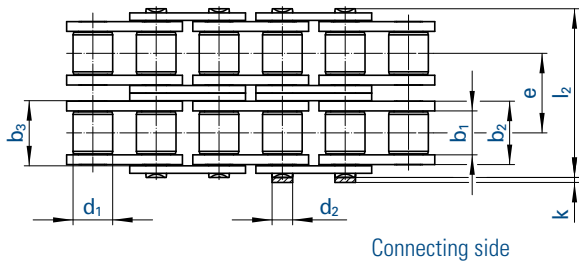

Triplex chains

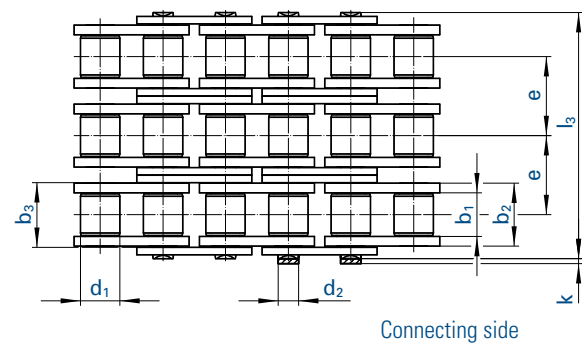

Chain according to ISO 606		Pitch		Inner width	Inner link width	Outer plate width	Roller \varnothing	Pin \varnothing	Transverse pitch	Plate height	Projection over connecting link	Width over pin	Bearing area	Breaking load	Weight	Connecting links
⚙️		p		b_1 min.	b_2 max.	b_3 min.	d_1 max.	d_2 max.	e	g max.	k max.	l max.	f	F_B min.	q \approx	
No.	Ind.	mm	inch	mm	mm	mm	mm	mm	mm	mm	mm	mm	cm ²	kN	kg/m	No.
08 A-1 MA		12,700	1/2	7,85	11,15	11,28	7,95	3,96	-	12,0	3,9	17,8	0,44	16,5	0,60	11,12,15
10 A-1 MA		15,875	5/8	9,40	13,80	13,93	10,16	5,08	-	15,0	4,1	21,8	0,70	30,0	1,01	11,12,15
12 A-1 MA		19,050	3/4	12,57	17,70	17,85	11,91	5,94	-	18,0	4,6	26,9	1,05	40,0	1,58	11,111,12,15
16 A-1 MA		25,400	1	15,75	22,50	22,70	15,88	7,92	-	24,1	5,4	33,5	1,78	69,0	2,36	11,111,12,15
20 A-1 MA		31,750	1 1/4	18,90	27,40	27,60	19,05	9,53	-	30,1	6,1	41,1	2,61	92,5	3,80	111,12
08 A-2 MA		12,700	1/2	7,85	11,15	11,28	7,95	3,96	14,38	12,0	3,9	32,3	0,88	29,7	1,20	11,12,15
10 A-2 MA		15,875	5/8	9,40	13,80	13,93	10,16	5,08	18,11	15,0	4,1	39,9	1,40	62,0	1,78	11,12,15
12 A-2 MA		19,050	3/4	12,57	17,70	17,85	11,91	5,94	22,78	18,0	4,6	49,8	2,10	76,0	3,15	11,111,12,15
16 A-2 MA		25,400	1	15,75	22,50	22,70	15,88	7,92	29,29	24,1	5,4	62,7	3,56	135,0	4,90	11,111,12,15
20 A-2 MA		31,750	1 1/4	18,90	27,40	27,60	19,05	9,53	35,76	30,1	6,1	77,0	5,22	205,0	7,60	111,12
08 A-3 MA		12,700	1/2	7,85	11,15	11,28	7,95	3,96	14,38	12,0	3,9	46,7	1,32	41,2	1,80	11,12,15
10 A-3 MA		15,875	5/8	9,40	13,80	13,93	10,16	5,08	18,11	15,0	4,1	57,9	2,10	88,0	3,02	11,12,15
12 A-3 MA		19,050	3/4	12,57	17,70	17,85	11,91	5,94	22,78	18,0	4,6	72,6	3,15	105,0	4,70	11,111,12,15
16 A-3 MA		25,400	1	15,75	22,50	22,70	15,88	7,92	29,29	24,1	5,4	91,7	5,35	193,0	7,50	11,111,12,15
20 A-3 MA		31,750	1 1/4	18,90	27,40	27,60	19,05	9,53	35,76	30,1	6,1	113,0	7,83	305,0	11,20	111,12

Sprockets on request.



Simplex chains

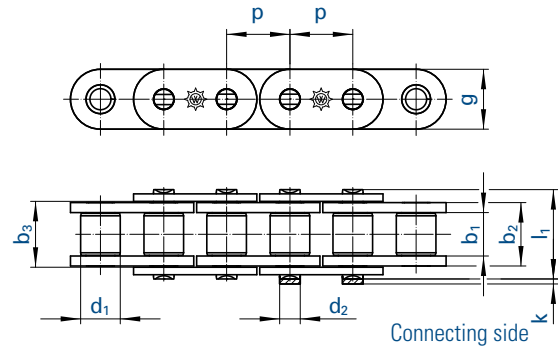

Duplex chains

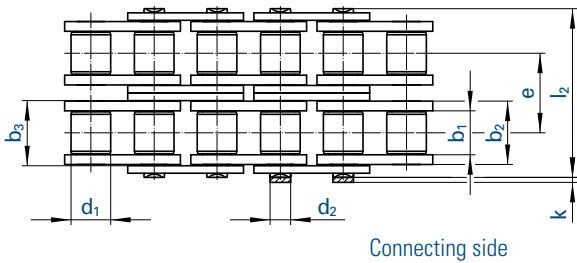

Triplex chains

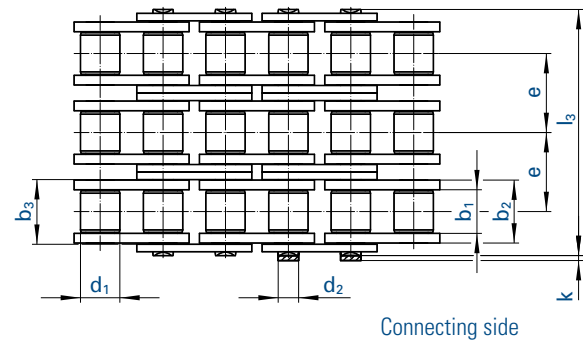

Chain according to ISO 606		Pitch		Inner width	Inner link width	Outer plate width	Roller Ø	Pin Ø	Transverse pitch	Plate height	Projection over connecting link	Width over pin	Bearing area	Breaking load	Weight	Connecting links
⚙️		p		b ₁ min.	b ₂ max.	b ₃ min.	d ₁ max.	d ₂ max.	e	g max.	k max.	l max.	f	F _B min.	q ≈	
No.	Ind.	mm	inch	mm	mm	mm	mm	mm	mm	mm	mm	mm	cm ²	kN	kg/m	No.
455 GL MA		9,525	3/8	5,72	8,53	8,66	6,35	3,28	-	8,2	3,3	13,5	0,28	9,6	0,41	4,7,11,12,15
462 GL MA		12,700	1/2	7,75	11,30	11,43	8,51	4,45	-	11,5	3,9	17,0	0,50	18,6	0,78	4,7,11,12
501 GL MA		15,875	5/8	9,65	13,28	13,41	10,16	5,08	-	14,2	4,1	19,6	0,67	27,0	1,03	4,7,11
513 GL MA		19,050	3/4	11,68	15,62	15,75	12,07	5,72	-	15,5	4,6	22,7	0,89	31,0	1,29	4,7,11,12
548 GL MA		25,400	1	17,02	25,40	25,60	15,88	8,28	-	24,0	5,4	36,1	2,10	72,0	3,29	4,7,11
548 GLS MA		25,400	1	17,02	25,40	25,60	15,88	8,28	-	21,0	5,4	36,1	2,10	72,0	2,90	4,7,11,12
563 GL MA		31,750	1 1/4	19,56	29,00	29,20	19,05	10,19	-	26,4	6,1	43,2	2,95	105,0	4,13	4,7,11,12
596 GL MA		38,100	1 1/2	25,40	37,90	38,20	25,40	14,63	-	33,4	6,6	53,4	5,54	180,0	7,34	4,7,11,12
455 GL-2 MA		9,525	3/8	5,72	8,53	8,66	6,35	3,28	10,24	8,2	3,3	23,8	0,56	17,4	0,86	4,7,11,12,15
462 GL-2 MA		12,700	1/2	7,75	11,30	11,43	8,51	4,45	13,92	11,5	3,9	31,0	1,01	37,0	1,50	4,7,11,12
501 GL-2 MA		15,875	5/8	9,65	13,28	13,41	10,16	5,08	16,59	14,2	4,1	36,2	1,34	54,0	2,00	4,7,11
513 GL-2 MA		19,050	3/4	11,68	15,62	15,75	12,07	5,72	19,46	15,5	4,6	42,2	1,79	63,0	2,62	4,7,11,12
548 GL-2 MA		25,400	1	17,02	25,40	25,60	15,88	8,28	31,88	24,0	5,4	68,0	4,21	140,0	5,83	4,7,11
563 GL-2 MA		31,750	1 1/4	19,56	29,00	29,20	19,05	10,19	36,45	26,4	6,1	79,0	5,81	210,0	8,03	4,7,11,12
596 GL-2 MA		38,100	1 1/2	25,40	37,92	38,20	25,40	14,63	48,36	33,4	6,6	101,0	11,09	360,0	14,47	4,7,11,12
455 GL-3 MA		9,525	3/8	5,72	8,53	8,66	6,35	3,28	10,24	8,2	3,3	34,0	0,81	24,9	1,30	4,7,11,12,15
462 GL-3 MA		12,700	1/2	7,75	11,30	11,43	8,51	4,45	13,92	11,5	3,9	44,9	1,51	56,0	2,21	4,7,11,12
501 GL-3 MA		15,875	5/8	9,65	13,28	13,41	10,16	5,08	16,59	14,2	4,1	52,8	2,02	80,0	2,97	4,7,11
513 GL-3 MA		19,050	3/4	11,68	15,62	15,75	12,07	5,72	19,46	15,5	4,6	61,7	2,68	94,0	3,43	4,7,11,12
548 GL-3 MA		25,400	1	17,02	25,40	25,60	15,88	8,28	31,88	24,0	5,4	99,9	6,31	211,0	8,25	4,7,11
563 GL-3 MA		31,750	1 1/4	19,56	29,00	29,20	19,05	10,19	36,45	26,4	6,1	116,0	8,87	300,0	11,66	4,7,11,12
596 GL-3 MA		38,100	1 1/2	25,40	37,90	38,20	25,40	14,63	48,36	33,4	6,6	150,0	16,63	523,0	22,00	4,7,11,12

Can also be supplied with attachments.

Chains 16-B GLS available with plate height g=21 mm (max.) and as type series GL with g=24 mm (max.)

Standard sprockets can be used for these chains.

Sprockets on request.

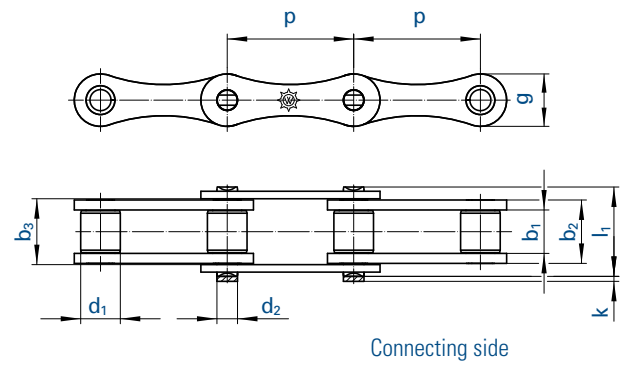

Chain according to ISO 1275		Pitch		Inner width	Inner link width	Outer plate width	Roller Ø	Pin Ø	Plate height	Projection over connecting link	Width over pin	Bearing area	Breaking load	Weight
⚙️		p		b ₁ min.	b ₂ max.	b ₃ min.	d ₁ max.	d ₂ max.	g max.	k max.	l ₁ max.	f	F _B min.	q ≈
No.	Ind.	mm	inch	mm	mm	mm	mm	mm	mm	mm	mm	cm ²	kN	kg/m
208 B MA		25,40	1	7,75	11,30	11,43	8,51	4,45	11,8	3,9	17,0	0,50	18,0	0,48
210 B MA		31,75	1 ¼	9,65	13,28	13,40	10,16	5,08	14,7	4,1	19,6	0,67	22,4	0,55
212 B MA		38,10	1 ½	11,68	15,62	15,75	12,07	5,72	16,1	4,6	22,7	0,89	29,0	0,80
216 B MA		50,80	2	17,02	25,40	25,60	15,88	8,28	21,0	5,4	36,1	2,10	60,0	1,74
220 B MA		63,50	2 ½	19,56	29,00	29,20	19,05	10,19	28,0	6,1	43,2	2,96	95,0	2,55

Sprockets for double pitch roller chains can be used for these chains.

Connecting links: According to ISO (...)



No. 4 (B)
Inner link



No. 7 (A)
Outer link
(to be riveted)



No. 111 (S)
Connecting link with
cottered pin



No. 208 (B)
for chain No. 713
with spring clip (E)



No. 12 (L)
Single
cranked link



Design E

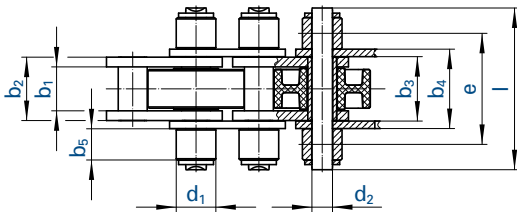
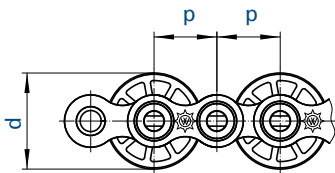

Double pitch chain Design L

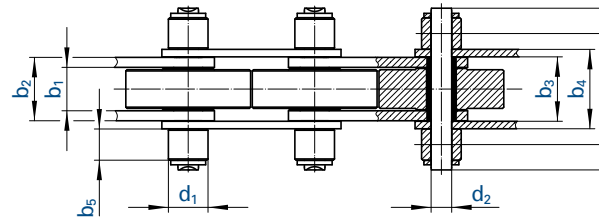
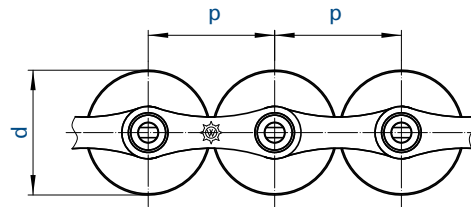

Chain	Pitch	Design	Inner width	Inner link width	Width		Support roller \varnothing	Pin \varnothing	Transverse pitch	Plate height	Width over pin	Support roller width	Width over pin Type I	Support roller width	
					between outer plates	over outer plates									
	p		b_1 min.	b_2 max.	b_3 min.	b_4 max.	d_1	d_2 max.	e	g max.	l max.	b_5 max.	l max.	b_5 max.	
No.	Ind.	mm	mm	mm	mm	mm	mm	mm	mm	mm	mm	mm	mm	mm	
513 SF MA		19,05	E	11,68	15,62	15,80	20,0	12,00	5,72	31,50	16,1	48,0	11,5	43,0	9,0
548 SF MA		25,40	E	17,02	25,45	25,81	32,0	15,88	8,28	44,50	21,0	65,0	12,5	-	-
722 SF MA		38,10	L	11,68	15,62	15,80	20,0	12,00	5,72	31,50	16,1	48,0	11,5	-	-
728 SF MA		50,80	L	17,02	25,45	25,81	32,0	15,88	8,28	44,50	21,0	65,0	12,5	-	-
D 513 SF MA		19,05	D	11,68	15,62	15,80	20,0	12,07	5,72	52,00	16,1	68,0	11,5	-	-
D 548 SF MA		25,40	D	17,02	25,45	25,81	32,0	15,88	8,28	76,76	21,0	97,0	12,5	-	-
T 513 SF MA		19,05	T	11,68	15,62	15,80	20,0	12,07	5,72	38,92	16,1	61,7	-	-	-
T 548 SF MA		25,40	T	17,02	25,45	25,81	32,0	15,88	8,28	63,76	21,0	99,9	-	-	-

Sprockets are available for all accumulator chains!

Connecting links with securing circlips.

Our connecting links always have the same length l as the ordinary pins.

Temperature range: - 30 to 100°C for steel conveyor rollers

- 10 to 60°C for plastic conveyor rollers

For information on AFS clips for optimal equipment and finger protection see page 60.



Design D

Design T

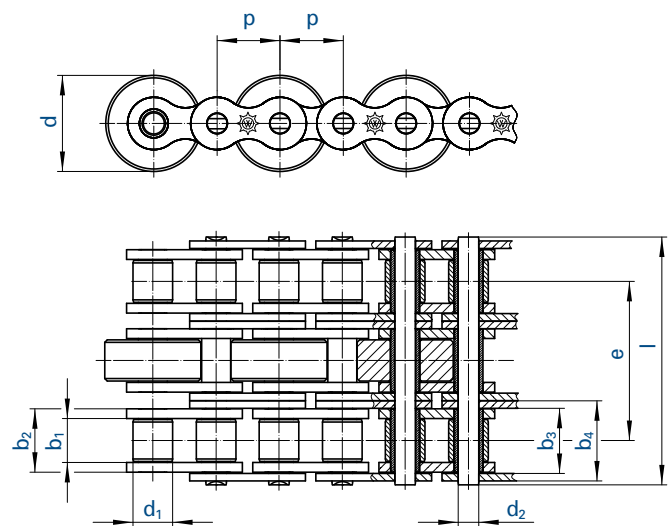
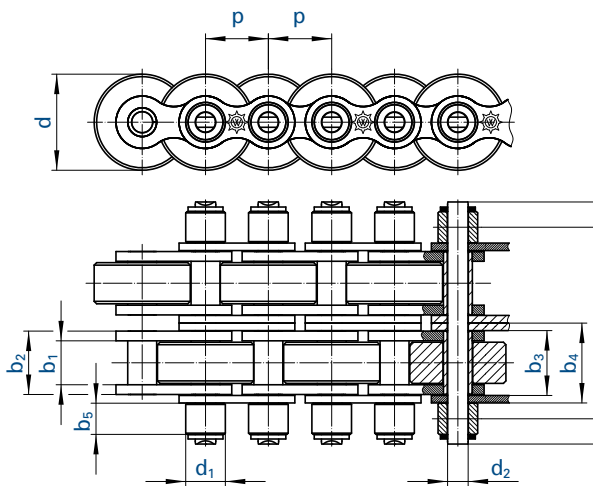

Width over pin Type II	Support roller width	Conveyor rollers						Breaking load ⚙️ FB min.	Maximum load per m conveyor chain with 10 m conveyor length	
		Designation for material			Diameter				Steel	Plastic
l max.	b5 max.	Steel	PA 6.6	Vestamide	d	Type I d	Type II d			
mm.	mm				mm	mm	mm	kN	kg	kg
40,0	7,5	SF	SFK	SFV	24,0	26,0	28,0	29,0	300	260
-	-	SF	SFK	SFV	38,5	-	-	60,0	600	500
-	-	SF	SFK	SFV	24,0	26,0	28,0	29,0	300	260
-	-	SF	SFK	SFV	38,5	40,0	50,0	60,0	600	500
-	-	SF	SFK	SFV	24,0	26,0	28,0	57,8	600	520
-	-	SF	SFK	SFV	38,5	-	-	120,0	1200	1000
-	-	SF	SFK	SFV	24,0	26,0	28,0	60,0	600	260
-	-	SF	SFK	SFV	38,5	-	-	120,0	1200	500

The load per m applies for 10 m conveyor length per double chain strand. The load may be proportionally increased for shorter chain lengths and must be proportionally decreased for longer conveyor distances: e.g. 5 m conveyor distance = double load, 20 m conveyor distance = half load.

Maximum conveyor distances 25 - 30 m. The installation of guide plates is recommended as of 15 m.



High performance polymer bearing TRIGLEIT



High performance polymer bearing TRIGLEIT Z

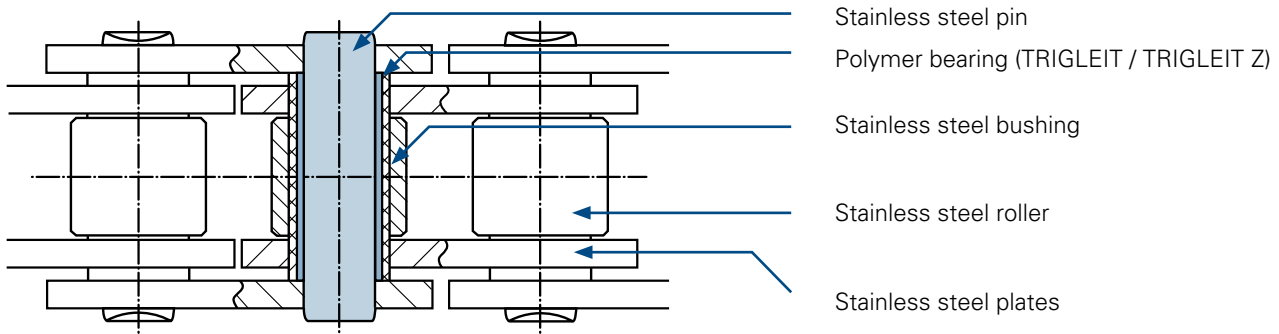

MARATHON stainless steel chains

For maximum freedom from maintenance and highest possible lifetime

High performance polymer bearings allow operation of stainless steel chains without relubrication!

Technical features

- Durable and low-friction polymer bearing
- All other chain components made of stainless steel grades
- Maximum chain speed $v = 2,5 \text{ m/s}$
- Working temperature -30°C to $+60^\circ\text{C}$ (TRIGLEIT)
- Working temperature -100°C to $+200^\circ\text{C}$ (TRIGLEIT Z / TRIGLEIT FDA)
- Chain dimensions according to ISO 606; standard stainless steel sprockets can be used
- No relubrication required
- Relubrication with mineral oils possible (no ester oils)
- Can also be supplied with extended pins, straight attachments, bent attachments and in special designs
- Information on chemical resistance on request
- Durable water resistance (TRIGLEIT Z / TRIGLEIT FDA)

Application areas

- Packing industry
- Chemical industry
- Pharmaceutical industry
- Textile industry
- Food industry
- Sanitation industry
- Electrical industry

Results of long-term wear tests

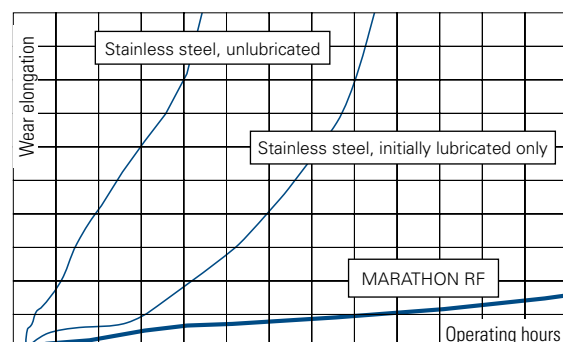



Simplex chains

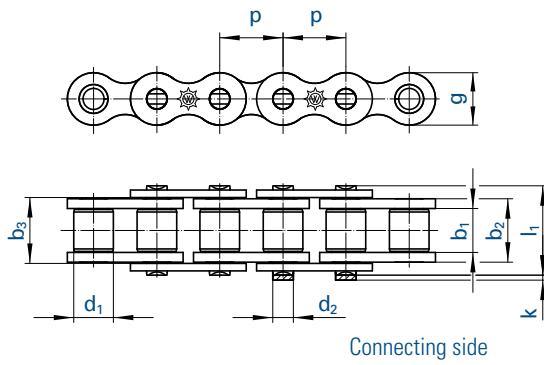

Simplex chains (Type GL)

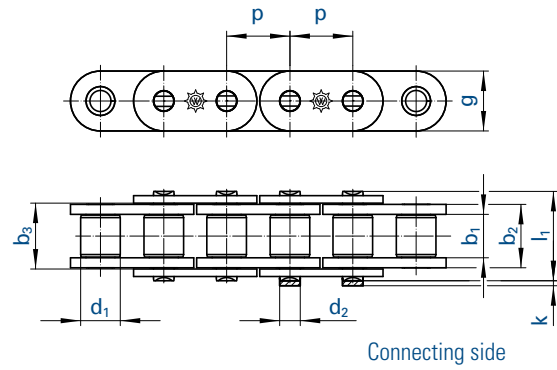

Duplex chains

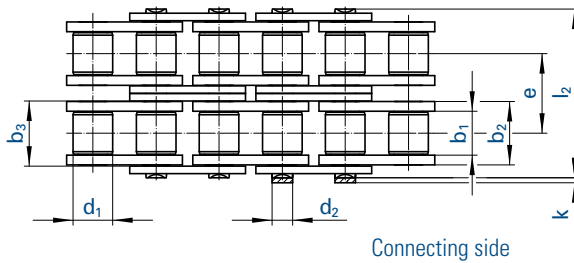

Triplex chains

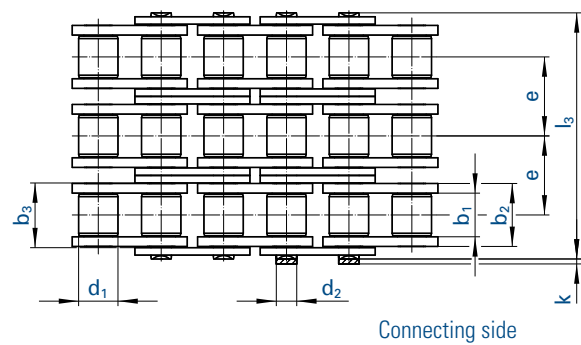

Chain		ISO	Pitch		Inner width	Inner link width	Outer plate width	Roller Ø	Pin Ø	Transverse pitch	Plate height	Projection over connecting link	Width over pin	Bearing area	Breaking load	Weight	Connecting links
No.	Ind.		mm	inch	b ₁ min.	b ₂ max.	b ₃ min.	d ₁ max.	d ₂ max.	e	g max.	k max.	l max.	f	F _B min.	q ≈	No.
462 RF MA	08 B-1	12,700	1/2	7,75	11,30	11,43	8,51	4,45	-	11,8	3,9	17,0	0,50	12,00	0,70	4,7,11,12,15	
501 RF MA	10 B-1	15,875	5/8	9,65	13,28	13,41	10,16	5,08	-	14,7	4,1	19,6	0,67	14,50	0,91	4,7,11,12,15	
513 RF MA	12 B-1	19,050	3/4	11,68	15,62	15,75	12,07	5,72	-	16,1	4,6	22,7	0,89	18,50	1,18	4,7,11,12,15	
548 RF MA	16 B-1	25,400	1	17,02	25,40	25,60	15,88	8,28	-	21,0	5,4	36,1	2,10	40,00	2,50	4,7,11,12	
D 462 RF MA	08 B-2	12,700	1/2	7,75	11,30	11,43	8,51	4,45	13,92	11,8	3,9	31,0	1,01	20,40	1,36	4,7,11,12,15	
D 501 RF MA	10 B-2	15,875	5/8	9,65	13,28	13,41	10,16	5,08	16,59	14,7	4,1	36,2	1,34	24,65	1,82	4,7,11,12,15	
D 513 RF MA	12 B-2	19,050	3/4	11,68	15,62	15,75	12,07	5,72	19,46	16,1	4,6	42,2	1,79	31,45	2,38	4,7,11,12,15	
D 548 RF MA	16 B-2	25,400	1	17,02	25,40	25,60	15,88	8,28	31,88	21,0	5,4	68,0	4,21	68,00	5,10	4,7,11,12	
T 462 RF MA	08 B-3	12,700	1/2	7,75	11,30	11,43	8,51	4,45	13,92	11,8	3,9	44,9	1,51	32,50	2,01	4,7,11,12,15	
T 501 RF MA	10 B-3	15,875	5/8	9,65	13,28	13,41	10,16	5,08	16,59	14,7	4,1	52,8	2,02	39,00	2,70	4,7,11,12,15	
T 513 RF MA	12 B-3	19,050	3/4	11,68	15,62	15,75	12,07	5,72	19,46	16,1	4,6	61,7	2,68	49,50	3,12	4,7,11,12,15	
T 548 RF MA	16 B-3	25,400	1	17,02	25,40	25,60	15,88	8,28	31,88	21,0	5,4	99,9	6,31	108,00	7,50	4,7,11,12	

Can also be supplied with attachments, straight plates (type series GL) and as double pitch roller chains (dimensions according to ISO 1275). Chains 548 available as type series GLs with plate height g = 21 mm (max.) and as type series GL with g = 24 mm (max.). Sprockets on request.

Connecting links: According to ISO (...)



No. 4 (B)
Inner link



No. 7 (A)
Outer link
(to be riveted)



No. 11 (E)
Spring clip
connecting link



No. 111 (S)
Connecting link
with cottered pin



No. 12 (L)
Single
cranked link



No. 15 (C)
Double
cranked link

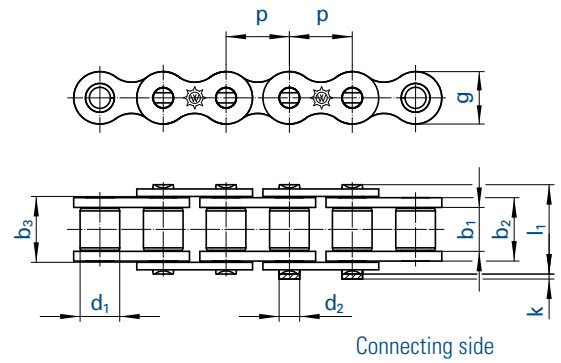

Chain according to ISO 606		Pitch	Inner width	Inner link width	Outer plate width	Roller Ø	Pin Ø	Plate height	Projection over connecting link	Width over pin	Bearing area	Breaking load	Weight	Connecting links
⚙		p	b ₁ min.	b ₂ max.	b ₃ min.	d ₁ max.	d ₂ max.	g max.	k max.	l ₁ max.	f	F _B min.	q ≈	
No.	Ind.	mm	mm	mm	mm	mm	mm	mm	mm	mm	cm ²	kN	kg/m	No.
450 RF	^{10,11}	8,000	3,00	4,77	4,90	5,00	2,31	7,1	3,1	8,6	0,11	4,0	0,18	4,7,11
331 RF	^{10,11}	12,700	3,30	5,80	5,93	7,75	3,66	9,9	1,5	10,2	0,21	7,0	0,28	4,7,11,15
332 RF	^{10,11}	12,700	4,88	7,20	7,33	7,75	3,66	9,9	1,5	11,2	0,28	7,0	0,33	4,7,11,15
462 RF	⁷	12,700	7,75	11,30	11,43	8,51	4,45	11,8	3,9	17,0	0,50	12,0	0,70	4,7,11,12,15
501 RF		15,875	9,65	13,28	13,41	10,16	5,08	14,7	4,1	19,6	0,67	14,5	0,91	4,7,11,12,15
513 RF		19,050	11,68	15,62	15,75	12,07	5,72	16,1	4,6	22,7	0,89	18,5	1,18	4,7,11,12,15
548 RF	¹¹	25,400	17,02	25,40	25,60	15,88	8,28	21,0	5,4	36,1	2,10	40,0	2,50	4,7,11,12
35 RF	^{2,11}	9,525	4,68	7,47	7,52	5,08	3,58	9,1	3,3	13,2	0,27	6,0	0,35	4,7,11
40 RF	^{10,11}	12,700	7,85	11,15	11,28	7,95	3,96	12,0	3,9	17,8	0,44	10,5	0,61	4,7,11,12,15
60 RF	¹¹	19,050	12,57	17,70	17,85	11,91	5,94	18,0	4,6	26,9	1,05	20,0	1,58	4,7,11,12
455 RFGL	^{10,11}	9,525	5,72	8,53	8,66	6,35	3,28	8,2	3,3	13,5	0,28	7,0	0,41	4,7,11,12,15
455 RFKIGL	^{2,7}	9,525	5,72	8,53	8,66	6,35	3,28	8,2	3,3	13,5	0,28	1,0	0,25	4,7,11
462 RFKI	^{2,7}	12,700	7,75	11,30	11,43	8,51	4,45	11,5	3,9	17,0	0,50	12,0	0,44	4,7,11
462 RFGL	²	12,700	7,75	11,30	11,43	8,51	4,45	11,5	3,9	17,0	0,50	12,0	0,78	4,7,11,12,15
501 RFGL		15,875	9,65	13,28	13,41	10,16	5,08	14,2	4,1	19,6	0,67	14,5	1,03	4,7,11,12,15
513 RFGL		19,050	11,68	15,62	15,75	12,07	5,72	15,5	4,6	22,7	0,89	18,5	1,29	4,7,11,12,15
548 RFGL	¹¹	25,400	17,02	25,40	25,60	15,88	8,28	24,0	5,4	36,1	2,10	40,0	3,29	4,7,11,12
548 RFGLS	¹¹	25,400	17,02	25,40	25,60	15,88	8,28	21,0	5,4	36,1	2,10	40,0	2,90	4,7,11,12

² without rollers (DIN 8154) ⁷ inner links made entirely of plastic, maintenance-free chain ¹⁰ connecting link No. 12 only with attached riveted bolts
¹¹ sprockets on request

Roller chains RF (stainless steel) - type series GL (straight plates) can also be supplied as multiplex roller chains. For details on orders and enquiries see page 131. For sprockets RF (stainless steel) see page 86.

Connecting links: According to ISO (...)



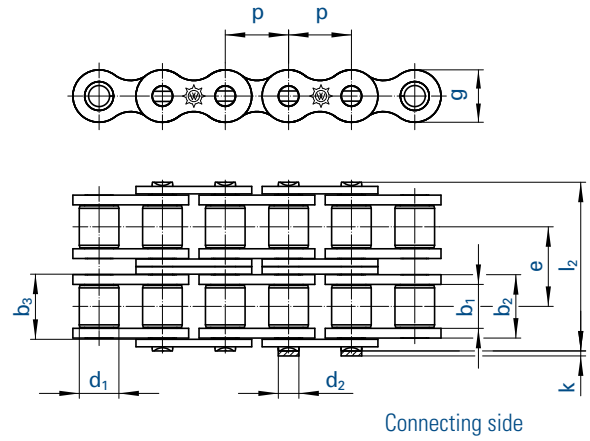

Chain according to ISO 606		Pitch	Inner width	Inner link width	Outer plate width	Roller Ø	Pin Ø	Transverse pitch	Plate height	Projection over connecting link	Width over pin	Bearing area	Breaking load	Weight	Connecting links
⚙		p	b ₁ min.	b ₂ max.	b ₃ min.	d ₁ max.	d ₂ max.	e	g max.	k max.	l ₂ max.	f	F _B min.	q ≈	
No.	Ind.	mm	mm	mm	mm	mm	mm	mm	mm	mm	mm	cm ²	kN	kg/m	No.
D450 RF		8,000	3,00	4,77	4,90	5,00	2,31	5,64	7,1	3,1	14,3	0,22	6,00	0,36	4,7,11,15
D455 RF	¹	9,525	5,72	8,53	8,66	6,35	3,28	10,24	8,2	3,3	23,8	0,56	11,90	0,78	4,7,11,15
D462 RF		12,700	7,75	11,30	11,43	8,51	4,45	13,92	11,8	3,9	31,0	1,01	20,40	1,36	4,7,11,12,15
D501 RF		15,875	9,65	13,28	13,41	10,16	5,08	16,59	14,7	4,1	36,2	1,34	24,65	1,82	4,7,11,12,15
D513 RF		19,050	11,68	15,62	15,75	12,07	5,72	19,46	16,1	4,6	42,2	1,79	31,45	2,38	4,7,11,12,15
D548 RF		25,400	17,02	25,40	25,60	15,88	8,28	31,88	21,0	5,4	68,0	4,21	68,00	5,10	4,7,11,12
35-2 RF		9,525	4,68	7,47	7,52	5,08	3,58	10,13	9,0	3,3	23,4	0,53	12,00	0,70	11,12,15
40-2 RF		12,700	7,85	11,15	11,28	7,95	3,96	14,38	12,0	3,9	32,3	0,88	17,85	1,20	11,12,15
60-2 RF		19,050	12,57	17,70	17,85	11,91	5,94	22,78	18,0	4,6	49,8	2,10	34,00	3,14	4,7,11,12

¹ with straight side plates

For details on orders and enquiries see page 131. Sprockets on request.

Connecting links: According to ISO (...)



No. 4 (B)
Inner link



No. 7 (A)
Outer link
(to be riveted)



No. 11 (E)
Spring clip
connecting link



No. 111 (S)
Connecting link
with cottered pin



No. 12 (L)
Single
cranked link



No. 15 (C)
Double cranked link

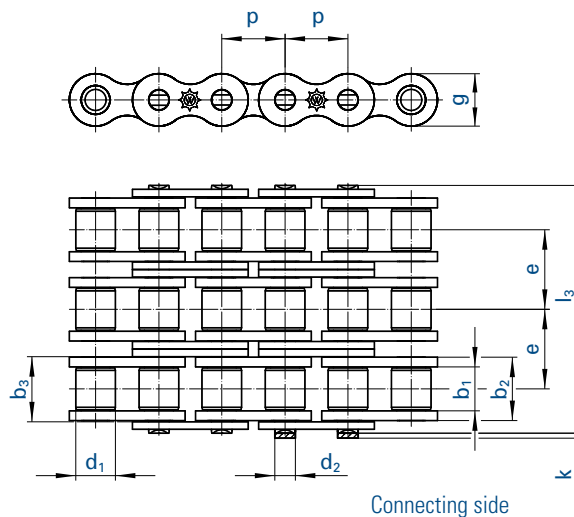

Chain according to ISO 606		Pitch		Inner width	Inner link width	Outer plate width	Roller Ø	Pin Ø	Transverse pitch	Plate height	Projection over connecting link	Width over pin	Bearing area	Breaking load	Weight	Connecting links
⚙		p		b ₁ min.	b ₂ max.	b ₃ min.	d ₁ max.	d ₂ max.	e	g max.	k max.	l ₃ max.	f	F _B min.	q ≈	
No.	Ind.	mm	inch	mm	mm	mm	mm	mm	mm	mm	mm	mm	cm ²	kN	kg/m	No.
T 455 RF	¹	9,525	3/8	5,72	8,53	8,66	6,35	3,28	10,24	8,2	3,3	34,0	0,81	18,9	1,18	11,12,15
T 462 RF		12,700	1/2	7,75	11,30	11,43	8,51	4,45	13,92	11,8	3,9	44,9	1,51	32,5	2,01	11,12,15
T 501 RF		15,875	5/8	9,65	13,28	13,41	10,16	5,08	16,59	14,7	4,1	52,8	2,02	39,0	2,70	11,12,15
T 513 RF		19,050	3/4	11,68	15,62	15,75	12,07	5,72	19,46	16,1	4,6	61,7	2,68	49,5	3,12	11,12,15
T 548 RF		25,400	1	17,02	25,40	25,60	15,88	8,28	31,88	21,0	5,4	99,9	6,31	108,0	7,50	111,12

¹ with straight side plates

For details on orders and enquiries see page 131, Sprockets on request.
Information on the selection of chain sizes and drives as of page 118.

Connecting links: According to ISO (...)



No. 4 (B)
Inner link



No. 7 (A)
Outer link
(to be riveted)



No. 11 (E)
Spring clip
connecting link



No. 111 (S)
Connecting link
with cottered pin



No. 12 (L)
Single
cranked link



No. 15 (C)
Double
cranked link

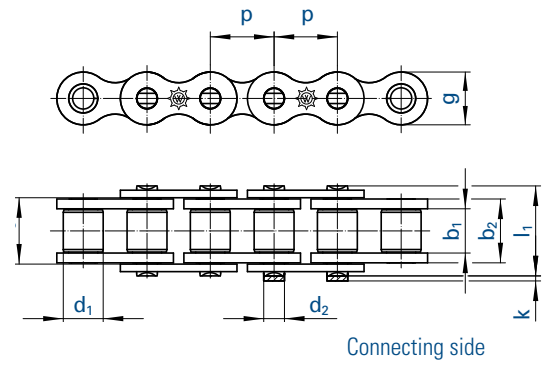

Chain		Pitch		Inner width	Inner link width	Outer plate width	Roller Ø	Pin Ø	Plate height	Projection over connecting link	Width over pin	Bearing area	Breaking load	Weight	Connecting links
⚙️		p		b ₁ min.	b ₂ max.	b ₃ min.	d ₁ max.	d ₂ max.	g max.	k max.	l ₁ max.	f	F _B min.	q ≈	
No.	Ind.	mm	inch	mm	mm	mm	mm	mm	mm	mm	mm	cm ²	kN	kg/m	No.
455 TL		9,525	3/8	5,72	8,53	8,66	6,35	3,28	9,0	3,3	13,5	0,28	9,0	0,41	4,7,11,12,15
18		12,700	1/2	4,88	9,30	9,43	7,75	4,18	11,2	1,5	14,4	0,39	17,5	0,55	4,7,11,12,15
460		12,700	1/2	5,21	8,70	8,93	8,51	4,45	11,8	3,9	15,0	0,39	18,2	0,62	4,7,11,15
515		19,050	3/4	13,50	19,70	19,83	12,07	5,72	16,2	4,6	28,6	1,12	35,0	1,67	4,7,11,12
517		19,050	3/4	11,68	17,00	17,13	12,07	6,10	18,1	3,6	24,9	1,05	40,0	1,51	4,7,11,12
546 b		25,400	1	12,70	20,00	20,20	14,00	7,50	22,5	5,4	30,0	1,48	58,0	2,14	4,7,11,12
547		25,400	1	12,70	21,07	21,27	15,88	8,28	21,0	5,4	30,9	1,74	63,0	2,50	4,7,11,12,111
577		35,000	-	19,60	27,00	27,20	19,05	10,19	26,0	6,1	40,0	2,74	85,0	2,90	4,7,11,12
6144	¹	41,500	-	20,70	26,90	27,28	15,90	9,05	26,3	5,0	38,1	2,40	56,0	2,59	4,7,111

¹ with straight side plates

For new installations we recommend to use only standardised roller chains according to ISO 606!
We reserve the right to cease production of this type series without prior notice!

For details on orders and enquiries see page 131. Sprockets on request.

Connecting links: According to ISO (...)



No. 4 (B)
Inner link



No. 7 (A)
Outer link
(to be riveted)



No. 11 (E)
Spring clip
connecting link



No. 111 (S)
Connecting link
with cottered pin



No. 12 (L)
Single
cranked link



No. 15 (C)
Double
cranked link

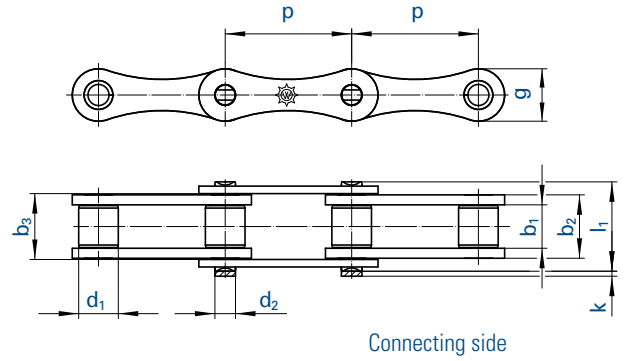

Chain		Pitch		Inner width	Inner link width	Outer plate width	Roller Ø	Pin Ø	Plate height	Projection over connecting link	Width over pin	Bearing area	Breaking load ISO	Weight	
ISO		p		b ₁ min.	b ₂ max.	b ₃ min.	d ₁ max.	d ₂ max.	g max.	k max.	l ₁ max.	f	F _B min.	q ≈	
No.	Ind.	No.	mm	inch	mm	mm	mm	mm	mm	mm	mm	cm ²	kN	kg/m	
713		208 B	25,40	1	7,75	11,30	11,43	8,51	4,45	11,8	3,9	17,0	0,50	18,0	0,46
717		210 B	31,75	1 ¼	9,65	13,28	13,41	10,16	5,08	14,7	4,1	19,6	0,67	22,4	0,57
722		212 B	38,10	1 ½	11,68	15,62	15,75	12,07	5,72	16,1	4,6	22,7	0,89	29,0	0,75
728		216 B	50,80	2	17,02	25,40	25,60	15,88	8,28	21,0	5,4	36,1	2,10	60,0	1,74
734		220 B	63,50	2 ½	19,56	29,00	29,20	19,05	10,19	28,5	6,1	43,2	2,96	95,0	2,55

Electrogalvanised or nickel-plated chains on request. In this case chains may only have 80 % of the tensile strength.

Double pitch roller chains (stainless steel)

713 RF		208 B	25,40	1	7,75	11,30	11,43	8,51	4,45	11,8	3,9	17,0	0,50	12,0	0,48
717 RF		210 B	31,75	1 ¼	9,65	13,28	13,41	10,16	5,08	14,7	4,1	19,6	0,67	14,5	0,55
722 RF		212 B	38,10	1 ½	11,68	15,62	15,75	12,07	5,72	16,1	4,6	22,7	0,89	18,5	0,80
728 RF		216 B	50,80	2	17,02	25,40	25,60	15,88	8,28	21,0	5,4	36,1	2,10	40,0	1,74

For details on orders and enquiries see page 131. Sprockets on request.
Information on the selection of chain sizes and drives as of page 118.

Connecting links: According to ISO (...)



No. 4 (B)
Inner link

No. 7 (A)
Outer link
(to be riveted)

No. 111 (S)
Connecting link
with cottered pin

No. 208 (B)
for chain No. 713
with spring clip (E)

No. 12 (L)
Single
cranked link

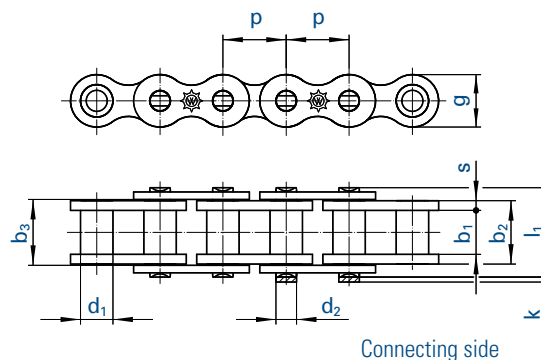

Chain		Pitch	Inner width	Inner link width	Outer plate width	Bushing \varnothing	Pin \varnothing	Width over pin	Projection over connecting link	Plate thickness	Plate height	Bearing area	Breaking load DIN	Weight	Connecting links
⚙		p	b_1 min.	b_2 max.	b_3 min.	d_1 max.	d_2 max.	l_1 max.	k	s	g max.	f	F_B min.	$q \approx$	
No.	Ind.	mm	mm	mm	mm	mm	mm	mm	mm	mm	mm	cm ²	kN	kg/m	No.
200	²⁶	15,0	14,0	18,50	19,00	9,0	6,0	26,0	2,0	2,00	14,0	1,1	12,5	1,25	4,7,111,12
203	²⁶	20,0	16,0	22,50	23,00	12,0	8,0	33,0	3,0	3,00	19,0	1,8	25,0	2,10	4,7,11,111,12
206	²⁶	25,0	18,0	24,50	25,00	15,0	10,0	37,0	3,5	3,00	24,0	2,5	31,5	2,60	4,7,111,12
209	²⁶	30,0	20,0	28,50	29,00	17,0	11,0	43,0	3,5	4,00	28,0	3,1	40,0	4,00	4,7,111,12
212	²⁶	35,0	22,0	30,50	31,00	18,0	12,0	46,0	4,5	4,00	30,0	3,7	50,0	4,30	4,7,111,12
215	²⁶	40,0	25,0	35,50	36,00	20,0	14,0	53,0	4,5	5,00	35,0	5,0	63,0	6,00	4,7,111,12
218	²⁶	45,0	30,0	42,50	43,00	22,0	16,0	63,0	4,5	6,00	40,0	6,8	80,0	8,00	4,7,111,12

²⁶ Connecting link No. 111 (S) with double cottered pin, i.e. projection k on both chain sides

For details on orders and enquiries see page 131. Sprockets on request.

Chain speeds with bush chains up to a pitch:

- of 20 mm ... up to 5 m/s
- of 40 mm ... up to 4 m/s
- more than 40 mm ... up to 3 m/s

Connecting links: According to ISO (...)



No. 4 (B)
Inner link



No. 7 (A)
Outer link
(to be riveted)



No. 11 (E)
Spring clip
connecting link



No. 111 (S)
Connecting link
with cottered pin



No. 12 (L)
Single
cranked link



Type A bent attachments, one side

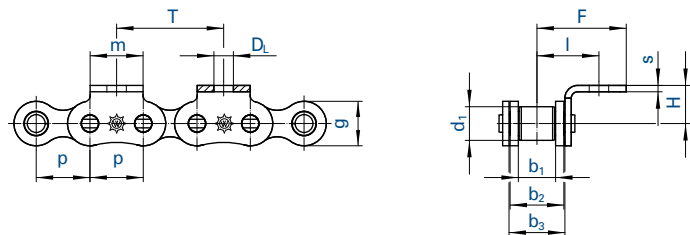

Type B bent attachments, both sides

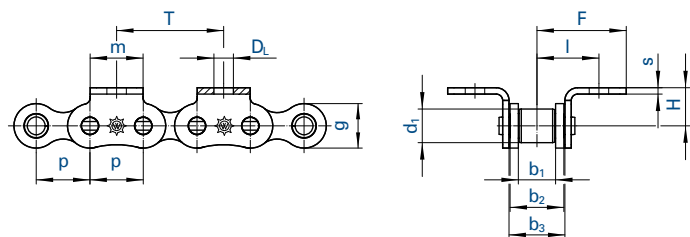

Type C bent over chain attachments, one side

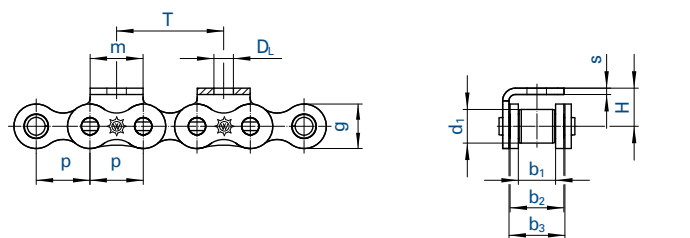

Basic chain		Pitch		Inner width	Inner link width	Outer plate width	Roller Ø	Plate height	Attachment dimensions					
No.	Ind.	p		b ₁ min.	b ₂ max.	b ₃ min.	d ₁ max.	g max.	m	D _L	l	F	H	s
		mm	inch	mm	mm	mm	mm	mm	mm	mm	mm	mm	mm	mm
450		8,000	-	3,00	4,77	4,90	5,00	7,1	8,0	3,2	6,6	12,0	5,0	0,80
455	^{1,15}	9,525	3/8	5,72	8,53	8,66	6,35	8,2	8,0	3,5	9,5	13,5	6,5	1,25
331	¹⁷	12,700	1/2	3,30	5,80	5,93	7,75	9,9	10,5	3,5	9,0	15,1	7,0	0,95
332	¹⁷	12,700	1/2	4,88	7,20	7,33	7,75	9,9	10,5	3,5	9,7	15,8	7,0	0,95
462	¹⁵	12,700	1/2	7,75	11,30	11,43	8,51	11,8	12,5	4,5	13,1	19,0	10,0	1,50
501	¹⁵	15,875	5/8	9,65	13,28	13,41	10,16	14,7	15,0	5,5	16,7	27,0	10,0	1,70
513	¹⁵	19,050	3/4	11,68	15,62	15,75	12,07	16,1	18,5	6,6	18,6	29,0	11,0	1,80
548	^{15,16}	25,400	1	17,02	25,40	25,60	15,88	21,0	25,0	9,0	28,9	41,8	18,0	3,00
563		31,750	1 1/4	19,56	29,00	29,20	19,05	26,4	35,0	9,0	33,4	49,0	18,0	3,75
596		38,100	1 1/2	25,40	37,90	38,20	25,40	33,4	38,0	11,0	44,0	64,0	25,0	5,00
613		44,450	1 3/4	30,99	46,50	46,80	27,94	37,0	45,0	14,0	54,1	78,0	32,0	6,00
652		50,800	2	30,99	45,50	45,80	29,21	42,2	50,0	14,0	54,0	76,3	35,0	6,00
40	¹⁵	12,700	1/2	7,85	11,15	11,28	7,95	12,0	10,5	3,5	12,7	17,9	7,9	1,50
50	¹⁵	15,875	5/8	9,40	13,80	13,93	10,16	15,0	12,7	5,2	15,9	23,9	10,3	2,00
60	¹⁵	19,050	3/4	12,57	17,70	17,85	11,91	18,0	15,9	5,2	19,1	28,2	11,9	2,40
80	¹⁵	25,400	1	15,75	22,50	22,70	15,88	24,1	19,1	6,7	25,4	37,3	15,9	3,20

¹ with straight side plates ¹⁵ also with single hole bent attachments on inner link ¹⁶ on inner link s = 4 ¹⁷ can also be supplied with m = 16

All designs can also be supplied as MARATHON roller chains (maintenance-free), BIATHLON, BIATHLON KS, TRIATHLON and TRIATHLON KS! For details on orders and enquiries see page 126. For untoleranced dimensions DIN ISO 2768 c applies.



Type D straight attachments, one side

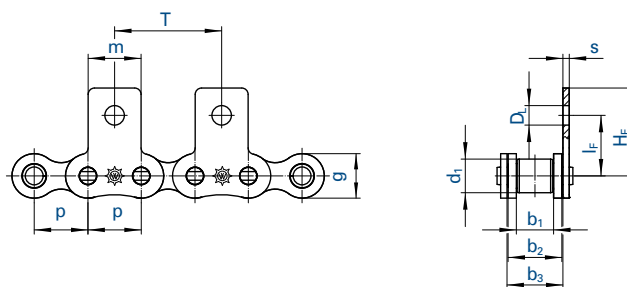

Type E straight attachments, both sides

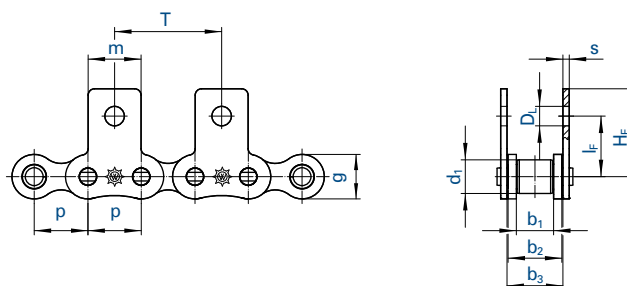

Type F extended pins (available on alternate sides)

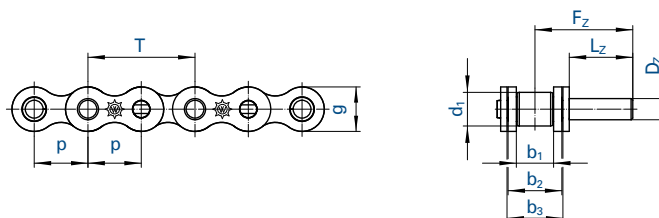

Basic chain		Pitch		Inner width	Inner link width	Outer plate width	Roller Ø	Plate height	Attachment dimensions							
⚙		p		b ₁ min.	b ₂ max.	b ₃ min.	d ₁ max.	g max.	m	D _L	l _F	H _F	s	D _Z ¹⁹ h9	L _Z ¹⁹	F _Z ¹⁹
No.	Ind.	mm	inch	mm	mm	mm	mm	mm	mm	mm	mm	mm	mm	mm	mm	mm
450		8,000	-	3,00	4,77	4,90	5,00	7,1	8,0	3,2	7,5	13,00	0,80	4,0	10,0	13,3
455	^{1,18}	9,525	3/8	5,72	8,53	8,66	6,35	8,2	8,0	3,5	9,0	13,80	1,25	5,0	15,0	20,7
331	¹⁷	12,700	1/2	3,30	5,80	5,93	7,75	9,9	10,5	3,5	11,3	17,65	0,95	5,0	15,0	19,0
332	¹⁷	12,700	1/2	4,88	7,20	7,33	7,75	9,9	10,5	3,5	11,5	17,65	0,95	5,0	15,0	19,7
462	¹⁸	12,700	1/2	7,75	11,30	11,43	8,51	11,8	12,5	4,5	14,7	20,30	1,50	6,0	15,0	22,4
501	¹⁸	15,875	5/8	9,65	13,28	13,41	10,16	14,7	15,0	5,5	17,2	26,70	1,70	6,5	20,0	28,5
513	¹⁸	19,050	3/4	11,68	15,62	15,75	12,07	16,1	18,5	6,6	18,7	29,00	1,80	7,0	20,0	29,8
548	^{16,18}	25,400	1	17,02	25,40	25,60	15,88	21,0	25,0	9,0	28,6	41,50	3,00	10,0	30,0	45,9
563		31,750	1 1/4	19,56	29,00	29,20	19,05	26,4	35,0	9,0	30,5	46,00	3,75	12,0	30,0	48,4
596		38,100	1 1/2	25,40	37,90	38,20	25,40	33,4	38,0	11,0	41,0	60,00	5,00	16,0	35,0	59,1
613		44,450	1 3/4	30,99	46,50	46,80	27,94	37,0	45,0	14,0	52,5	75,50	6,00	20,0	40,0	69,0
652		50,800	2	30,99	45,50	45,80	29,21	42,2	50,0	14,0	53,5	77,00	6,00	20,0	40,0	69,0
40		12,700	1/2	7,85	11,15	11,28	7,95	12,0	10,5	3,5	11,5	17,65	1,50	5,0	15,0	22,2
50		15,875	5/8	9,40	13,80	13,93	10,16	15,0	12,7	5,2	15,9	23,50	2,00	5,08	11,9	21,1
60		19,050	3/4	12,57	17,70	17,85	11,91	18,0	15,9	5,2	18,3	27,20	2,40	5,94	14,3	25,8
80		25,400	1	15,75	22,50	22,70	15,88	24,1	19,1	6,7	24,6	35,50	3,20	7,92	19,1	33,7

¹ with straight side plates ¹⁶ on inner link s = 4 ¹⁷ can also be supplied with m = 16 ¹⁸ also with straight attachments on inner link

¹⁹ other dimensions available on request

All designs can also be supplied as MARATHON roller chains (maintenance-free), BIATHLON, BIATHLON KS, TRIATHLON and TRIATHLON KS! For details on orders and enquiries see page 132. For untoleranced dimensions DIN ISO 2768 c applies.



Type A2 bent attachments, one side

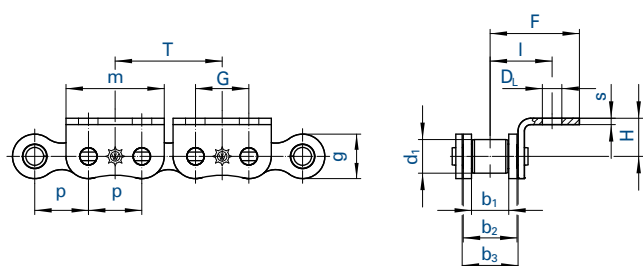

Type B2 bent attachments, both sides

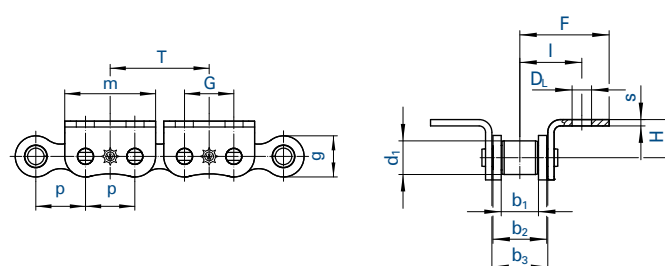

Type D2 straight attachments, one side

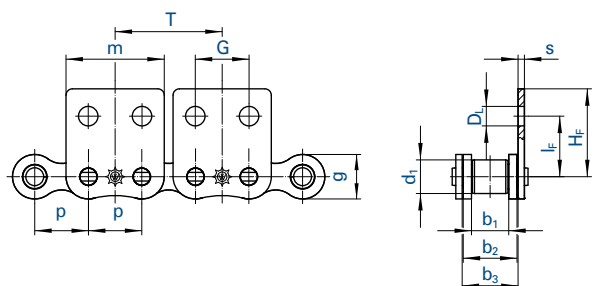

Type E2 straight attachments, both sides

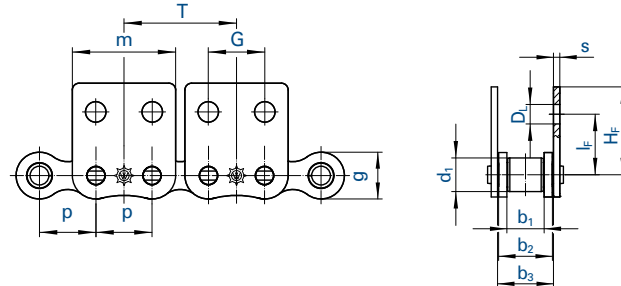

Basic chain		Pitch		Inner width	Inner link width	Outer plate width	Roller Ø	Plate height	Attachment dimensions								
⚙		p		b ₁ min.	b ₂ max.	b ₃ min.	d ₁ max.	g max.	m	D _L	G	I	F	H	I _F	H _F	s
No.	Ind.	mm	inch	mm	mm	mm	mm	mm	mm	mm	mm	mm	mm	mm	mm	mm	mm
455	^{1,20}	9,525	3/8	5,72	8,53	8,66	6,35	8,2	18,2	3,2	9,5	9,8	13,2	5,7	9,2	12,6	1,25
462		12,700	1/2	7,75	11,30	11,43	8,51	11,8	23,2	4,5	12,7	13,1	19,0	10,0	14,7	20,3	1,50
501		15,875	5/8	9,65	13,28	13,41	10,16	14,7	28,5	5,5	15,9	16,7	27,0	10,0	17,2	26,7	1,70
513		19,050	3/4	11,68	15,62	15,75	12,07	16,1	34,8	6,6	19,1	18,6	29,0	11,0	18,7	29,0	1,80
548		25,400	1	17,02	25,40	25,60	15,88	21,0	46,5	9,0	25,4	28,9	42,0	18,0	28,6	41,5	3,00
563		31,750	1 1/4	19,56	29,00	29,20	19,05	26,4	55,8	9,0	31,8	33,4	49,0	18,0	30,5	46,0	3,75
596		38,100	1 1/2	25,40	37,90	38,20	25,40	33,4	71,1	11,0	38,1	44,0	64,0	25,0	41,0	60,0	5,00

Roller chains (stainless steel) with two-hole bent and straight attachments

455 RF	^{1,20}	9,525	3/8	5,72	8,53	8,66	6,35	8,2	18,2	3,2	9,5	9,8	13,2	5,7	9,2	12,6	1,25
462 RF		12,700	1/2	7,75	11,30	11,43	8,51	11,8	23,2	4,5	12,7	13,1	19,0	10,0	14,7	20,3	1,60
501 RF		15,875	5/8	9,65	13,28	13,41	10,16	14,7	28,5	5,5	15,9	16,7	27,0	10,0	17,2	26,7	1,70
513 RF		19,050	3/4	11,68	15,62	15,75	12,07	16,1	34,8	6,6	19,1	18,5	29,0	11,0	18,7	29,0	1,80
548 RF		25,400	1	17,02	25,40	25,60	15,88	21,0	46,5	10,0	25,4	28,9	41,8	18,0	28,6	41,5	3,00

¹ with straight side plates ²⁰ can be supplied with or without bore

All designs can also be supplied as MARATHON roller chains (maintenance-free), BIATHLON, BIATHLON KS, TRIATHLON and TRIATHLON KS! Sprockets made of stainless steel or plastic are available on request.

For details on orders and enquiries see page 132. For untoleranced dimensions DIN ISO 2768 c applies.



Type A bent attachments, one side

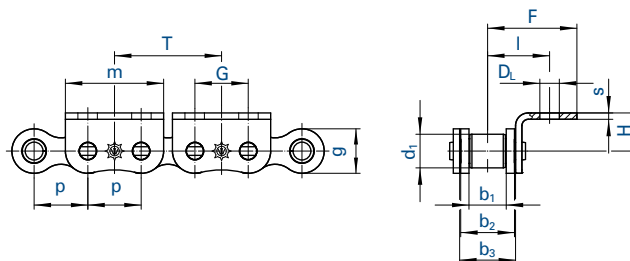

Type B bent attachments, both sides

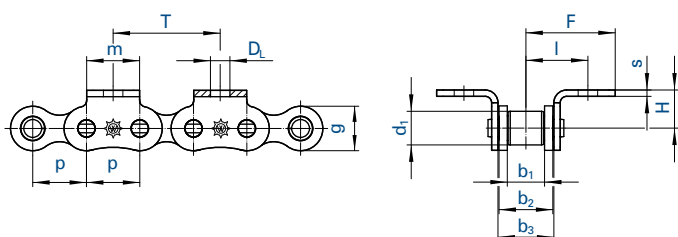

Type D straight attachments, one side

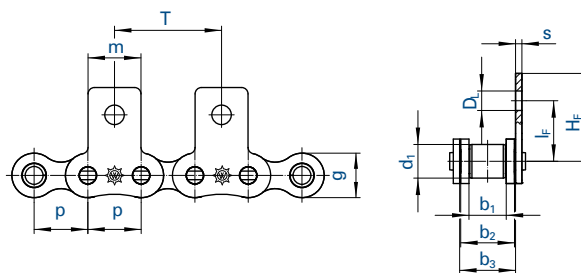

Type E straight attachments, both sides

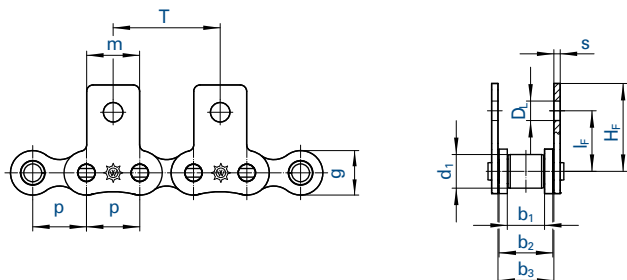

Type F extended pins (available on alternate sides)

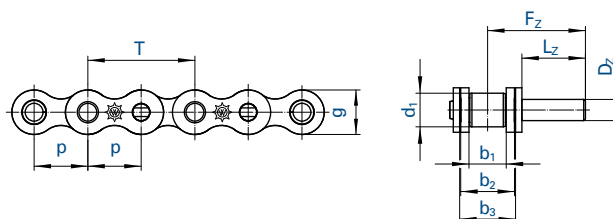

Basic chain		Pitch	Inner width	Inner link width	Outer plate width	Roller Ø	Plate height	Attachment dimensions											
								p	b ₁ min.	b ₂ max.	b ₃ min.	d ₁ max.	g max.	m	D _L	I	F	H	I _F
No.	Ind.	mm	mm	mm	mm	mm	mm	mm	mm	mm	mm	mm	mm	mm	mm	mm	mm	mm	mm
450 RF		8,000	3,00	4,77	4,90	5,00	7,1	8,0	3,2	6,6	12,0	5,0	7,5	13,0	0,80	4,0	10	13,3	
455 RF	^{1,21}	9,525	5,72	8,53	8,66	6,35	8,2	8,0	3,5	9,5	13,5	6,5	9,0	13,4	1,25	5,0	15	20,7	
331 RF	¹⁷	12,700	3,30	5,80	5,93	7,75	9,9	10,5	3,5	9,0	15,1	7,0	11,3	17,7	0,95	5,0	15	19,0	
40 RF	²¹	12,700	7,85	11,15	11,28	7,95	12,0	10,5	3,5	11,8	17,9	7,9	11,5	17,7	1,50	5,0	15	22,2	
332 RF	¹⁷	12,700	4,88	7,20	7,33	7,75	9,9	10,5	3,5	9,7	15,8	7,0	11,5	17,7	0,95	5,0	15	19,7	
462 RF	²¹	12,700	7,75	11,30	11,43	8,51	11,8	12,5	4,5	13,1	19,0	10,0	14,7	20,3	1,60	6,0	15	22,4	
501 RF	²¹	15,875	9,65	13,28	13,41	10,16	14,7	15,0	5,5	16,7	27,0	10,0	17,2	26,7	1,70	6,5	20	28,5	
513 RF	²¹	19,050	11,68	15,62	15,75	12,07	16,1	18,5	6,6	18,5	29,0	11,0	18,7	29,0	1,80	7,0	20	29,8	
548 RF	^{16,21}	25,400	17,02	25,40	25,60	15,88	21,0	25,0	10,0	28,9	41,8	18,0	28,6	41,5	3,00	10,0	30	45,9	

¹ with straight side plates ¹⁶ on inner link s = 4 ¹⁷ can also be supplied with m = 16 ¹⁹ other dimensions available on request ²¹ also with single hole bent attachments on inner link

Sprockets made of stainless steel or plastic are available on request.

For details on orders and enquiries see page 132. For untoleranced dimensions DIN ISO 2768 c applies.



Type A G

bent attachments, one side

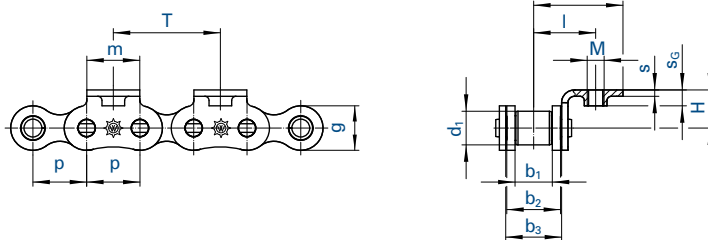

Type B G

bent attachments, both sides

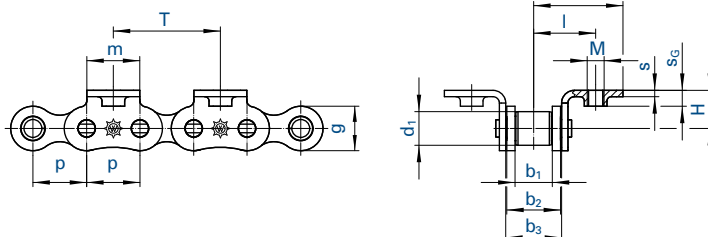

Type C G

bent over chain attachments, one side

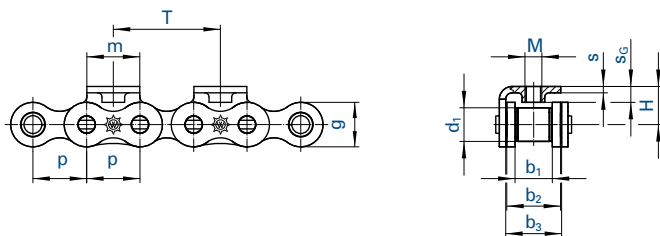

Type D G

straight attachments, one side

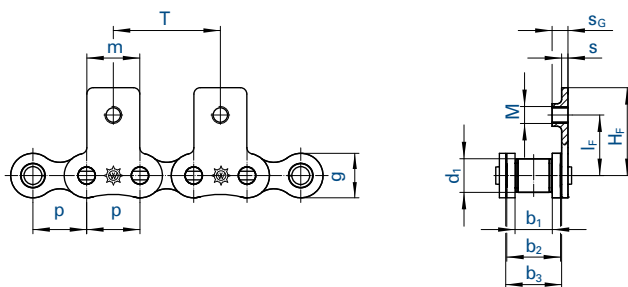

Type E G

straight attachments, both sides

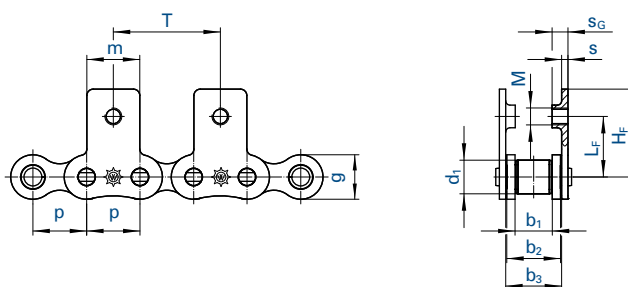

Basic chain		Pitch		Inner width	Inner link width	Outer plate width	Roller Ø	Plate height	Attachment dimensions						
No.	Ind.	p		b ₁ min.	b ₂ max.	b ₃ min.	d ₁ max.	g max.	m	M (Inside thread)	I	F	H	s	s _G
		mm	inch	mm	mm	mm	mm	mm	mm	mm	mm	mm	mm	mm	mm
462	²²	12,700	1/2	7,75	11,30	11,43	8,51	11,8	12,5	M 4	13,1	19,0	10	1,50	4,00
501	²²	15,875	5/8	9,65	13,28	13,41	10,16	14,7	15,0	M 5	16,7	27,0	10	1,70	4,20
513	²²	19,050	3/4	11,68	15,62	15,75	12,07	16,1	18,5	M 6	18,6	29,0	11	1,80	4,50
548	²²	25,400	1	17,02	25,40	25,60	15,88	21,0	25,0	M 8	28,9	41,8	18	3,00	7,50

²² can also be supplied in stainless steel

All designs can also be supplied as MARATHON roller chains (maintenance-free), BIATHLON, BIATHLON KS, TRIATHLON and TRIATHLON KS! For details on orders and enquiries see page 132. For untoleranced dimensions DIN ISO 2768 c applies.



Type A 2 G

bent attachments, one side

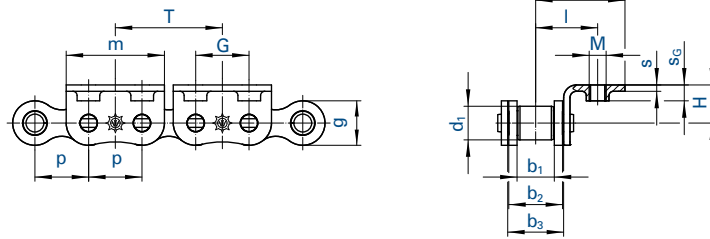

Type B 2 G

bent attachments, both sides

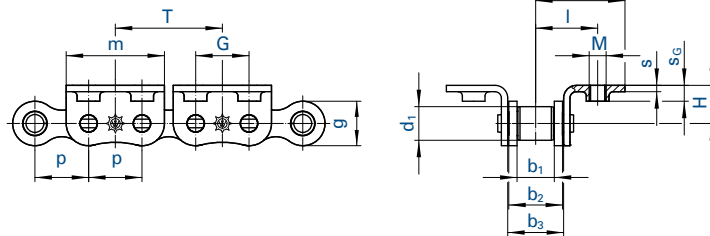

Type C 2 G

bent over chain attachments,
one side

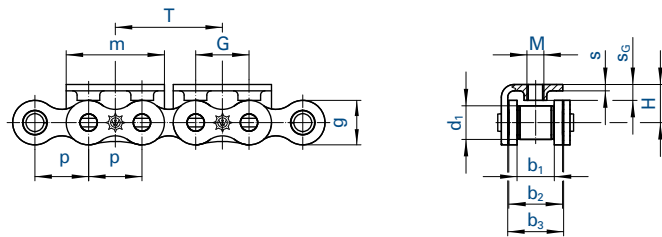

Type D 2 G

straight attachments, one side

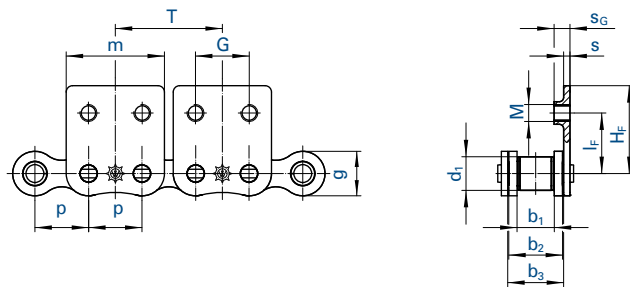

Type E 2 G

straight attachments, both sides

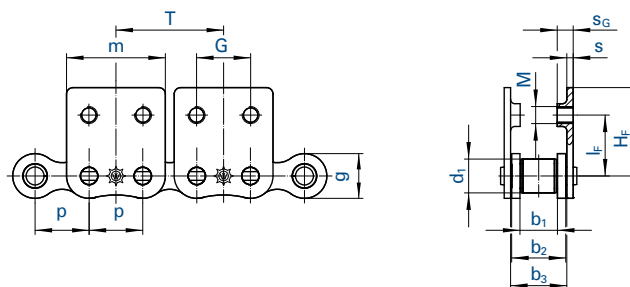

Basic chain		Pitch	Inner width	Inner link width	Outer plate width	Roller Ø	Plate height	Attachment dimensions									
⚙		p	b ₁ min.	b ₂ max.	b ₃ min.	d ₁ max.	g max.	m	M (Inside thread)	G	l	F	H	l _F	H _F	s	s _G
No.	Ind.	mm	mm	mm	mm	mm	mm	mm		mm	mm	mm	mm	mm	mm	mm	mm
462	²²	12,700	7,75	11,30	11,43	8,51	11,8	23,2	M 4	12,7	13,1	19,0	10	14,7	20,3	1,50	4,00
501	²²	15,875	9,65	13,28	13,41	10,16	14,7	28,5	M 5	15,9	16,7	27,0	10	17,2	26,7	1,70	4,20
513	²²	19,050	11,68	15,62	15,75	12,07	16,1	34,8	M 6	19,1	18,5	29,0	11	18,7	29,0	1,80	4,50
548	²²	25,400	17,02	25,40	25,60	15,88	21,0	46,5	M 8	25,4	28,9	41,8	18	28,6	41,5	3,00	7,50

²² can also be supplied in stainless steel

All designs can also be supplied as MARATHON roller chains (maintenance-free), BIATHLON, BIATHLON KS, TRIATHLON and TRIATHLON KS! For details on orders and enquiries see page 132. For untoleranced dimensions DIN ISO 2768 c applies.



Type A
bent attachments, one side

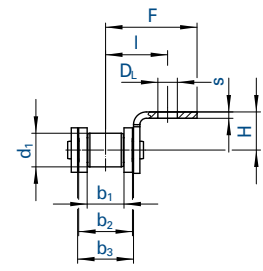
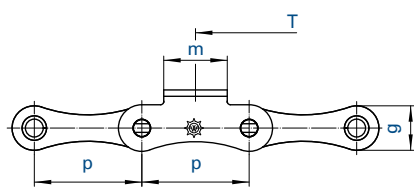

Type B
bent attachments, both sides

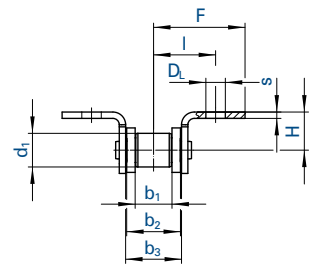
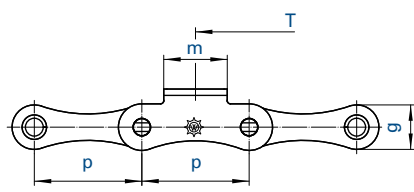

Type C
bent over chain attachments, one side

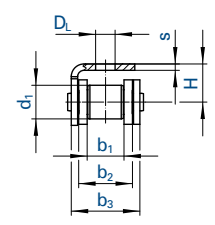
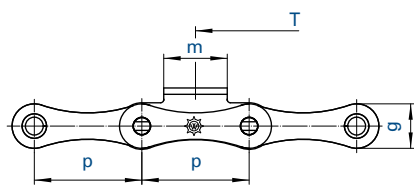

Basic chain		Pitch		Inner width	Inner link width	Outer plate width	Roller Ø	Plate height	Attachment dimensions					
⚙		p		b ₁ min.	b ₂ max.	b ₃ min.	d ₁ max.	g max.	m	D _L	l	F	H	s
No.	Ind.	mm	inch	mm	mm	mm	mm	mm	mm	mm	mm	mm	mm	mm
713		25,40	1	7,75	11,30	11,43	8,51	11,8	13,0	4,5	13,1	19,3	10,0	1,60
717		31,75	1 ¼	9,65	13,28	13,41	10,16	14,7	15,0	5,5	16,7	26,7	10,0	1,70
722		38,10	1 ½	11,68	15,62	15,75	12,07	16,1	19,0	6,6	18,5	26,0	11,0	1,80
728		50,80	2	17,02	25,40	25,60	15,88	21,0	30,0	9,0	28,9	43,0	18,0	3,00
734		63,50	2 ½	19,56	29,00	29,20	19,05	28,5	35,0	9,0	33,1	49,6	18,0	3,75

Double pitch stainless steel roller chains with single hole bent attachments

713 RF		25,40	1	7,75	11,30	11,43	8,51	11,8	13,0	4,5	13,1	19,5	10,0	1,60
717 RF		31,75	1 ¼	9,65	13,28	13,41	10,16	14,7	15,0	5,5	16,7	26,7	10,0	1,70
722 RF		38,10	1 ½	11,68	15,62	15,75	12,07	16,1	19,0	6,6	18,5	26,0	11,0	1,80
728 RF		50,80	2	17,02	25,40	25,60	15,88	21,0	30,0	9,0	28,9	43,0	18,0	3,00

¹⁹ other dimensions available on request

All designs can also be supplied as MARATHON roller chains (maintenance-free)!
For details on orders and enquiries see page 132. For untoleranced dimensions DIN ISO 2768 c applies.

Type D
straight attachments, one side

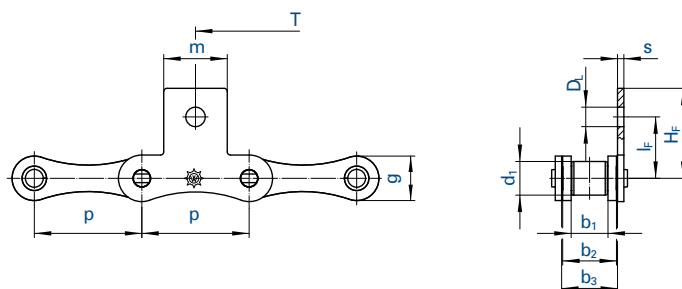

Type E
straight attachments, both sides

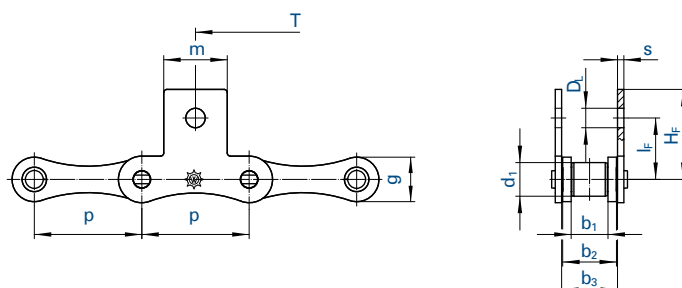

Type F
extended pin
(available on alternate sides)

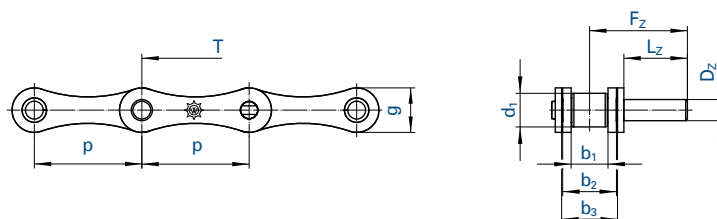

Basic chain		Pitch		Inner width	Inner link width	Outer plate width	Roller Ø	Plate height	Attachment dimensions							
									p	b_1 min.	b_2 max.	b_3 min.	d_1 max.	g max.	m	D_L
No.	Ind.	mm	inch	mm	mm	mm	mm	mm	mm	mm	mm	mm	mm	mm	mm	mm
713		25,40	1	7,75	11,30	11,43	8,51	11,8	13,0	4,5	14,7	20,3	1,60	6,0	15,0	22,4
717		31,75	1 ¼	9,65	13,28	13,41	10,16	14,7	15,0	5,5	17,0	26,7	1,70	6,5	20,0	28,5
722		38,10	1 ½	11,68	15,62	15,75	12,07	16,1	19,0	6,6	17,6	26,0	1,80	7,0	20,0	29,8
728		50,80	2	17,02	25,40	25,60	15,88	21,0	30,0	9,0	29,0	42,5	3,00	10,0	30,0	45,9
734		63,50	2 ½	19,56	29,00	29,20	19,05	28,5	35,0	9,0	30,5	45,7	3,75	12,0	30,0	48,4

Double pitch roller chains (stainless steel) with single hole straight attachments and extended pins

713 RF		25,40	1	7,75	11,30	11,43	8,51	11,8	13,0	4,5	14,7	20,3	1,60	6,0	15,0	22,4
717 RF		31,75	1 ¼	9,65	13,28	13,41	10,16	14,7	15,0	5,5	17,0	26,7	1,70	6,5	20,0	28,5
722 RF		38,10	1 ½	11,68	15,62	15,75	12,07	16,1	19,0	6,6	17,6	26,0	1,80	7,0	20,0	29,8
728 RF		50,80	2	17,02	25,40	25,60	15,88	21,0	30,0	9,0	29,0	42,5	3,00	10,0	30,0	45,9

¹⁹ can also be supplied in stainless steel

Can also be supplied as MARATHON roller chain (maintenance-free)!

For details on orders and enquiries see page 132. For untoleranced dimensions DIN ISO 2768 c applies.

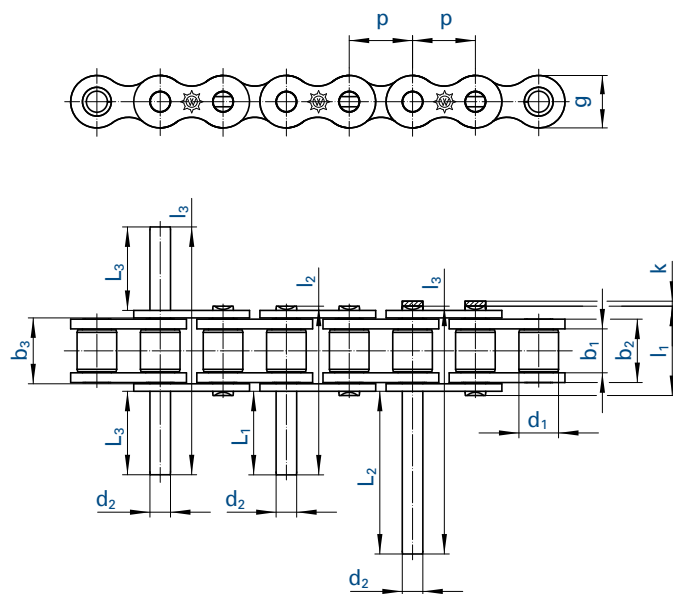

Basic chain		Pitch		Inner width	Inner link width	Outer plate width	Roller Ø	Pin Ø	Projection over connecting link	Plate height	Width over pin	Dimensions for extended pin				
		p		b ₁ min.	b ₂ max.	b ₃ min.	d ₁ max.	d ₂ max.	k max.	g max.	l ₁ max.	Overall length		Pin extension		
No.	Ind.	mm	inch	mm	mm	mm	mm	mm	mm	mm	mm	l ₂ ¹¹ max.	l ₃ ¹² max.	L ₁ max.	L ₂ max.	L ₃ max.
450		8,000	-	3,00	4,77	4,90	5,00	2,31	3,1	7,1	8,6	14,3	19,9	6,3	12,2	6,35
455	^{1,10}	9,525	3/8	5,72	8,53	8,66	6,35	3,28	3,3	8,2	13,5	23,1	33,7	11,0	21,6	11,15
462	¹⁰	12,700	1/2	7,75	11,30	11,43	8,51	4,45	3,9	11,8	17,0	30,7	44,9	15,3	29,5	15,30
501	¹⁰	15,875	5/8	9,65	13,28	13,41	10,16	5,08	4,1	14,7	19,6	36,2	52,8	18,2	34,8	18,00
513	¹⁰	19,050	3/4	11,68	15,62	15,75	12,07	5,72	4,6	16,1	22,7	41,8	61,3	21,0	40,5	20,90
548	¹⁰	25,400	1	17,02	25,40	25,60	15,88	8,28	5,4	21,0	36,0	67,5	99,3	33,6	65,4	33,70
552	¹⁰	30,000	-	17,02	25,40	25,60	15,88	8,28	5,4	21,0	36,0	67,5	99,3	33,6	65,4	33,70
563		31,750	1 1/4	19,56	29,00	29,20	19,05	10,19	6,1	26,4	41,5	78,0	114,7	38,6	75,3	38,70
577		35,000	-	19,60	27,00	27,20	19,05	10,19	6,1	26,0	38,3	78,0	114,7	41,8	78,5	41,80
596		38,100	1 1/2	25,40	37,90	38,20	25,40	14,63	6,6	33,4	53,0	101,3	149,5	50,5	98,7	50,50
613		44,450	1 3/4	30,99	46,50	46,80	27,94	15,90	7,4	37,0	63,6	122,9	182,9	61,7	121,7	62,00
652		50,800	2	30,99	45,50	45,80	29,21	17,81	7,9	42,2	63,6	123,0	182,0	62,2	121,2	62,10
35	¹⁰	9,525	3/8	4,68	7,47	7,52	5,08	3,59	3,3	9,1	13,2	22,0	32,5	11,0	21,5	11,10
40	¹⁰	12,700	1/2	7,85	11,15	11,28	7,95	3,96	3,9	12,0	17,8	30,1	45,2	14,8	29,9	15,35
50	¹⁰	15,875	5/8	9,40	13,80	13,93	10,16	5,08	4,1	15,0	20,5	38,7	56,8	19,4	37,5	19,40
60	¹⁰	19,050	3/4	12,57	17,70	17,85	11,91	5,94	4,6	18,0	25,4	48,3	71,1	24,2	47,0	24,20
80		25,400	1	15,75	22,50	22,70	15,88	7,92	5,4	24,1	33,5	62,6	92,0	31,3	60,6	31,30
100		31,750	1 1/4	18,90	27,40	27,60	19,05	9,53	6,1	30,1	40,4	76,3	112,2	38,2	74,1	38,20
120		38,100	1 1/2	25,22	35,30	35,60	22,23	11,10	6,6	36,2	50,3	96,1	141,9	48,2	94,0	48,20

¹ with straight side plates ¹⁰ can also be supplied in stainless steel ¹¹ Duplex pin ¹² Triplex pin

All designs can also be supplied as MARATHON roller chains (maintenance-free), BIATHLON, BIATHLON KS, TRIATHLON and TRIATHLON KS! For details on orders and enquiries see page 132. For untoleranced dimensions DIN ISO 2768 c applies.

Simplex chain with duplex connecting link

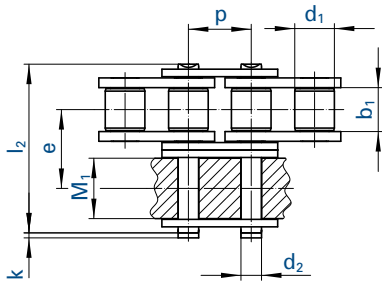

Simplex chain with triplex connecting link

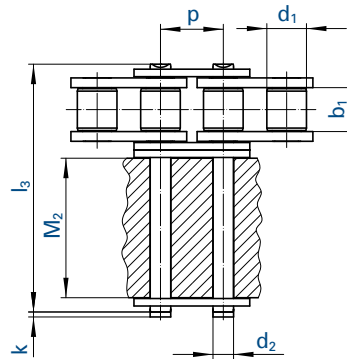

Simplex chain with duplex connecting link

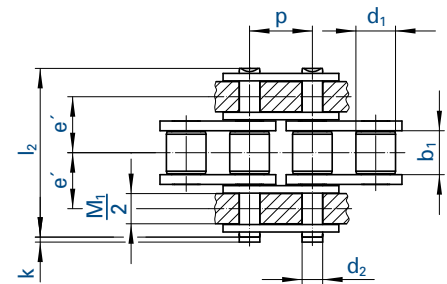

Duplex chain with triplex connecting link

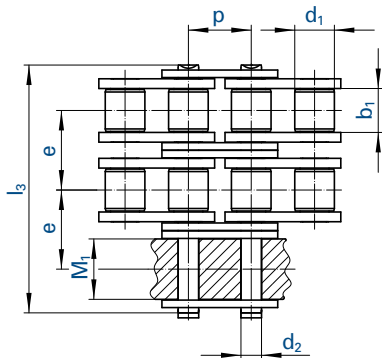

Duplex chain with triplex connecting link

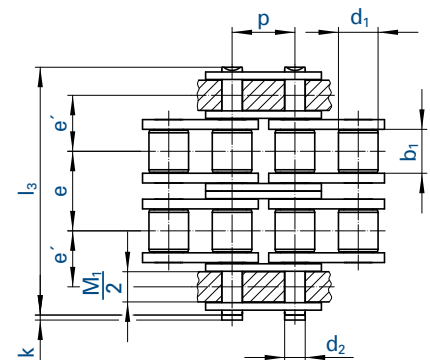

Chain		Pitch		Inner width	Roller Ø	Pin Ø	Transverse pitch		Attachment width		Projection over connecting link k max.	Pin length	
No.	Ind.	mm	inch	b ₁ min.	d ₁ max.	d ₂ max.	e	e'	M ₁ max.	M ₂ max.		l ₂ max.	l ₃ max.
455	¹⁰	9,525	3/8	5,72	6,35	3,28	10,24	7,24	8,5	-	3,3	23,8	-
D 455	¹⁰	9,525	3/8	5,72	6,35	3,28	10,24	7,24	8,5	-	3,3	-	34,0
462	¹⁰	12,700	1/2	7,75	8,51	4,45	13,92	10,10	11,3	25,6	3,9	31,0	-
D 462	¹⁰	12,700	1/2	7,75	8,51	4,45	13,92	10,10	11,3	-	3,9	-	44,9
501	¹⁰	15,875	5/8	9,65	10,16	5,08	16,59	11,62	13,3	30,0	4,1	36,2	-
D 501	¹⁰	15,875	5/8	9,65	10,16	5,08	16,59	11,62	13,3	-	4,1	-	52,8
513	¹⁰	19,050	3/4	11,68	12,07	5,72	19,46	13,63	15,6	34,8	4,6	42,2	-
D 513	¹⁰	19,050	3/4	11,68	12,07	5,72	19,46	13,63	15,6	-	4,6	-	61,7
548	¹⁰	25,400	1	17,02	15,88	8,28	31,88	22,30	25,4	56,8	5,4	68,0	-
D 548	¹⁰	25,400	1	17,02	15,88	8,28	31,88	22,30	25,4	-	5,4	-	99,9

¹⁰ can also be supplied in stainless steel

All designs can also be supplied as MARATHON roller chains (maintenance-free), BIATHLON, BIATHLON KS, TRIATHLON and TRIATHLON KS! For details on orders and enquiries see page 132. For untoleranced dimensions DIN ISO 2768 c applies.



Pusher dog

Secure transport of general cargo

During conveyance the WIPPERMANN pusher is at right angles to the chain. In the deflection phase it submerges under the transported material without damaging it.

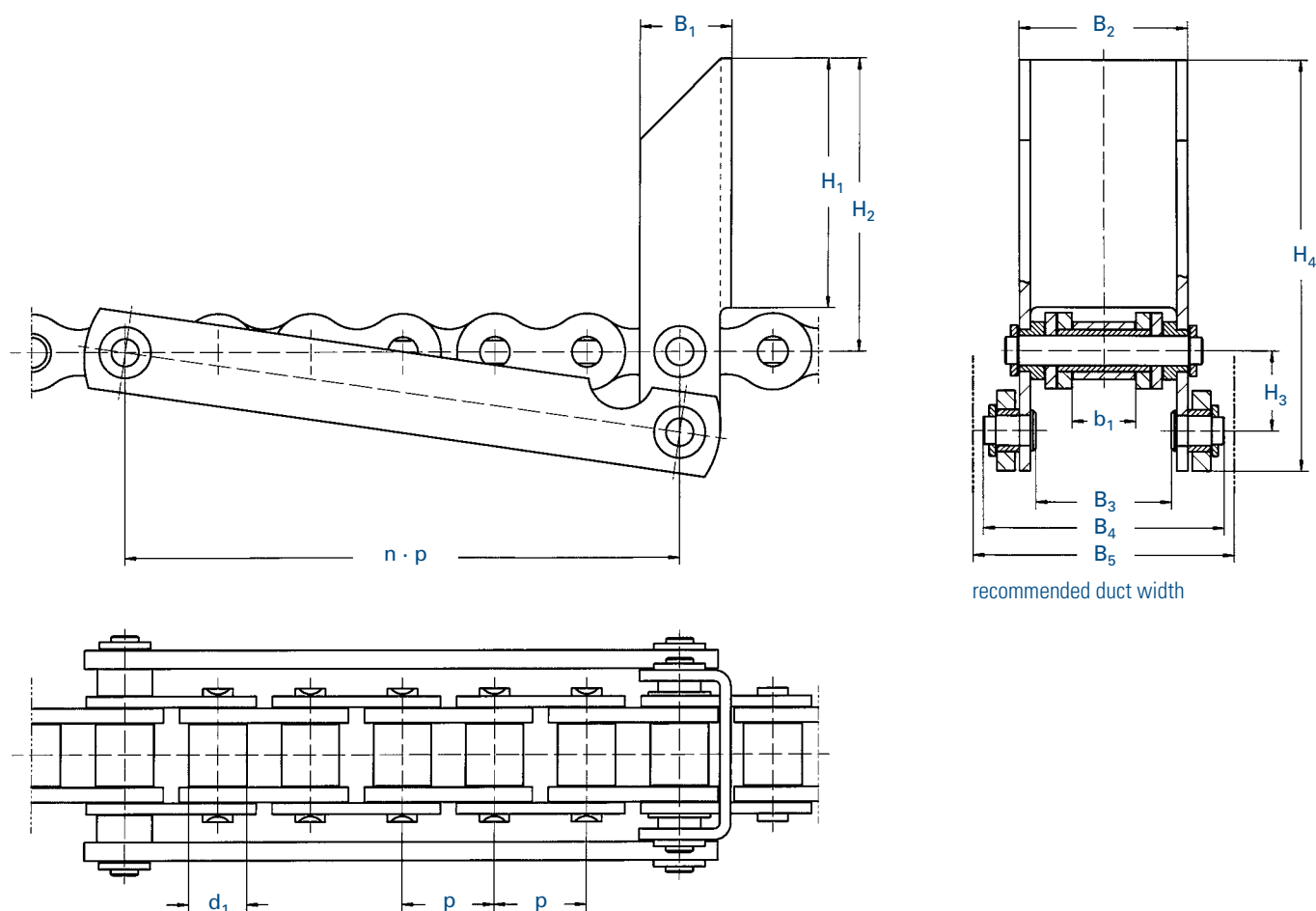

recommended duct width

Chain	Sprockets		Pitch p	Inner width b_1 min.	Roller \varnothing d_1 max.	Pusher dog dimensions										Thrust max. kN	
	Number of teeth	Hub \varnothing max.				B_1	B_2	B_3	B_4	B_5	H_1	H_2	H_3	H_4	n		
No.	Ind.		mm	mm	mm	mm	mm	mm	mm	mm	mm	mm	mm	mm	mm		
462 / M 120	¹⁰	20	32	12,700	7,75	8,51	18,0	25,0	19,0	35,0	40,0	22,0	29,0	11,0	46,0	5	0,5
501 / M 132	¹⁰	32	80	15,875	9,65	10,16	18,0	31,0	23,0	40,0	45,0	50,0	60,0	18,0	86,0	8	1,0
501 / M 133	¹⁰	24	60	15,875	9,65	10,16	18,0	31,0	23,0	40,0	45,0	50,0	60,0	14,0	82,0	6	1,0
548 / M 132	¹⁰	24	90	25,400	17,02	15,88	25,0	46,0	37,0	65,0	70,0	68,0	80,0	22,0	113,0	6	3,0

¹⁰ can also be supplied in stainless steel

All designs can also be supplied as MARATHON roller chains (maintenance-free), BIATHLON, BIATHLON KS, TRIATHLON and TRIATHLON KS! For details on orders and enquiries see page 132. For untoleranced dimensions DIN ISO 2768 c applies.



Special top plate conveyor chain

For cross-linking of systems

The main advantage compared to previous solutions is that the top plates are no component parts of the inner and outer links of the actual chain.

The plates are attached in the hollow pin as a separate assembly part. This specific DBGM protected construction characteristic (DBGM 295 05 477.8) allows for the top plates to be replaced even with a tensioned chain, i.e. the chain does not have to be separated.

Due to an additional short pin attached to the top plate the plate is twist-secured. The floating assembly of the top plate can compensate minor height differences of the slideways.

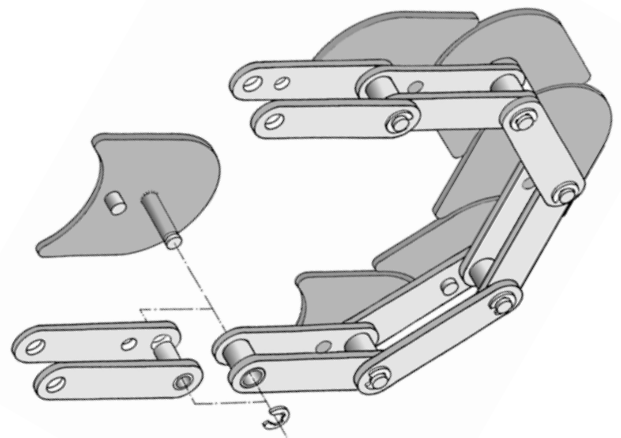

- Apart from that we have succeeded in considerably reducing the distance between the plates compared to previous solutions.
- The sickle-shaped conveyor plates allow unrestricted motion through narrow bends and curves.
- Owing to the special construction of the WIPPERMANN special top plate conveyor chain an identical run of the top plate and the basic chain is guaranteed.
- In order to facilitate assembly and disassembly, the top plates were mounted with circlips.
- The WIPPERMANN special top plate conveyor chain with its especially narrow chain plate construction ensures a larger bearing area of the top plates on the guide profiles.

- The top plates are coated and therefore have a high wear protection.
- The WIPPERMANN special top plate conveyor chain is fully compatible with other systems.

Top plate conveyor chains suitable for following curved paths are installed in particular for long conveyor distances and high loads.

Primarily, they are required by the beverage and food industry and by subcontractors to the automotive industry.

Sprockets on request.

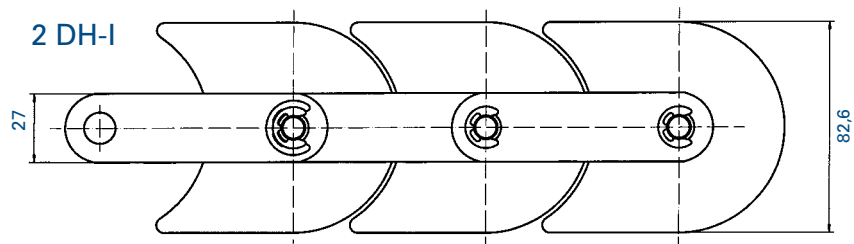

Chain	Weight	Minimum tensile strength
No.	kg/m	kN
2 DH-I	3,4	55,0

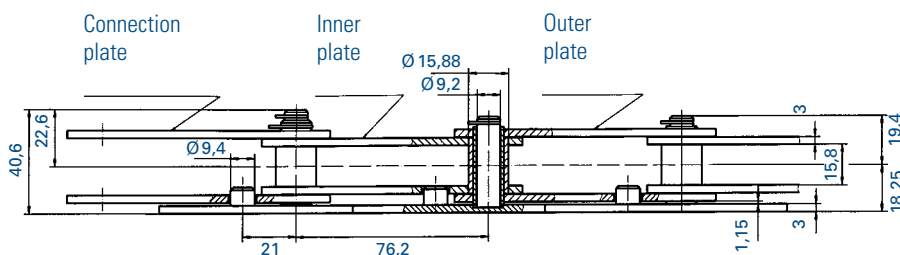

Design E

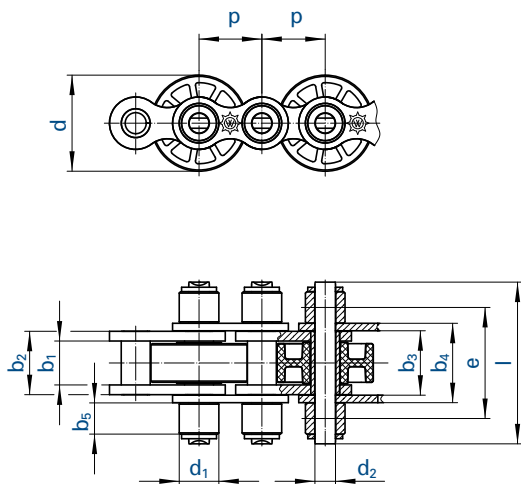

Double pitch roller chain Design L

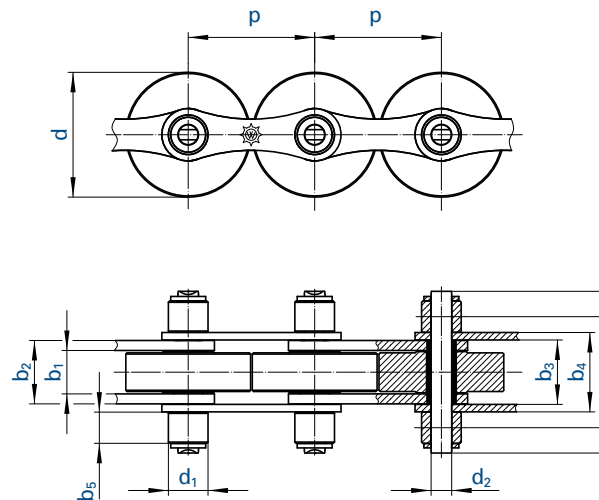

Chain	Pitch	Design	Inner width	Inner link width	Width between over outer plates		Support roller \varnothing	Pin \varnothing	Transverse pitch	Plate height	Width over pin	Support roller width	Width over pin type I	Support roller width
					b_3 min.	b_4 max.								
No.	Ind.	mm	mm	mm	mm	mm	mm	mm	mm	mm	mm	mm	mm	mm
513 SF	19,050	E	11,68	15,62	15,80	20,0	12,00	5,72	31,50	16,1	48,0	11,5	43,0	9,0
548 SF	25,400	E	17,02	25,45	25,81	32,0	15,88	8,28	44,50	21,0	65,0	12,5	-	-
722 SF	38,100	L	11,68	15,62	15,80	20,0	12,00	5,72	31,50	16,1	48,0	11,5	-	-
728 SF	50,800	L	17,02	25,45	25,81	32,0	15,88	8,28	44,50	21,0	65,0	12,5	-	-
D 513 SF	19,050	D	11,68	15,62	15,80	20,0	12,07	5,72	52,00	16,1	68,0	11,5	-	-
D 548 SF	25,400	D	17,02	25,45	25,81	32,0	15,88	8,28	76,76	21,0	97,0	12,5	-	-
T 455 SF	9,525	T	5,72	8,53	-	-	6,35	3,28	20,48	8,2	34,0	-	-	-
T 513 SF	19,050	T	11,68	15,62	15,80	20,0	12,07	5,72	38,92	16,1	61,7	-	-	-
T 548 SF	25,400	T	17,02	25,45	25,81	32,0	15,88	8,28	63,76	21,0	99,9	-	-	-

Accumulator chains (stainless steel)

513 SF RF	19,050	E	11,68	15,62	15,80	20,0	12,00	5,72	31,50	16,1	48,0	11,5	43,0	9,0
548 SF RF	25,400	E	17,02	25,45	25,81	32,0	15,88	8,28	44,50	21,0	65,0	12,5	-	-
722 SF RF	38,100	L	11,68	15,62	15,80	20,0	12,00	5,72	31,50	16,1	48,0	11,5	-	-
728 SF RF	50,800	L	17,02	25,45	25,81	32,0	15,88	8,28	44,50	21,0	65,0	12,5	-	-
T 513 SF RF	19,050	T	11,68	15,62	-	-	12,07	5,72	38,92	16,1	61,7	-	-	-
T 548 SF RF	25,400	T	17,02	25,45	-	-	15,88	8,28	63,76	21,0	99,9	-	-	-

²⁷ Different from the drawing: No inner links in the middle strand! Roller width: 8,5 mm.

Sprockets are available for all accumulator chains!

Connecting links with securing circlips.

Our connecting links always have the same length l as the ordinary pins.

Temperature range: - 30 to 100°C for steel conveyor rollers

- 10 to 60°C for plastic conveyor rollers

Design D

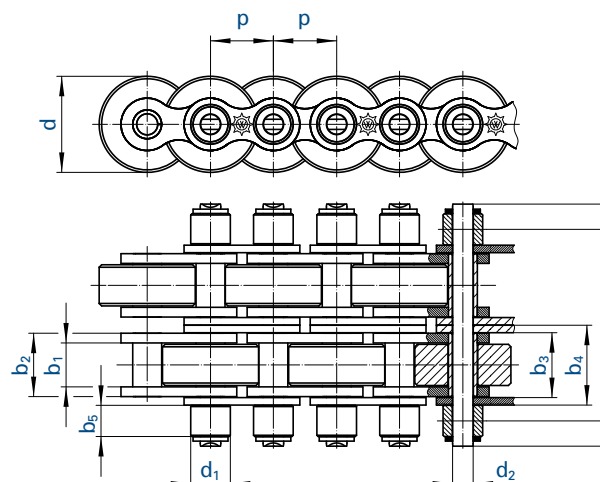

Design T

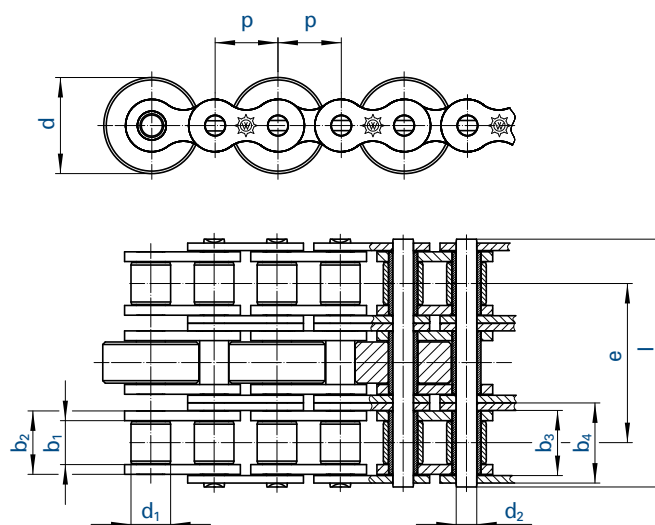

Width over pin type II l max.	Support roller width b ₅ max.	Conveyor rollers						Breaking load ⚙ F _B min.	Maximum load per m conveyor chain with 10 m conveyor length	
		Designation for material			Diameter				Steel	Plastic
		Steel	PA 6.6	Vestamide	d	type I d	type II d			
mm.	mm				mm	mm	mm	kg	kg	
40,0	7,5	SF	SFK	SFV	24,0	26,0	28,0	29,00	300	260
-	-	SF	SFK	SFV	38,5	-	-	60,00	600	500
-	-	SF	SFK	SFV	24,0	26,0	28,0	29,00	300	260
-	-	SF	SFK	SFV	38,5	40,0	50,0	60,00	600	500
-	-	SF	SFK	SFV	24,0	26,0	28,0	57,80	600	520
-	-	SF	SFK	SFV	38,5	-	-	120,00	1200	1000
-	-	SF	SFK	SFV	9,2	15,0	-	16,80	100	100
-	-	SF	SFK	SFV	24,0	26,0	28,0	60,00	600	260
-	-	SF	SFK	SFV	38,5	-	-	120,00	1200	500

Accumulator chains (stainless steel)

40,0	7,5	SF RF	SFK RF	SFV RF	24,0	26,0	28,0	18,50	200	200
-	-	SF RF	SFK RF	SFV RF	38,5	-	-	40,00	300	300
-	-	SF RF	SFK RF	SFV RF	24,0	26,0	28,0	18,50	200	200
-	-	SF RF	SFK RF	SFV RF	38,5	40,0	50,0	40,00	300	300
-	-	SF RF	SFK RF	SFV RF	24,0	26,0	28,0	31,45	400	400
-	-	SF RF	SFK RF	SFV RF	38,5	-	-	68,00	600	600

The load per m applies for 10 m conveyor distance per double chain strand. The load may be proportionally increased for shorter chain strands and must be proportionally decreased for longer conveyor distances: e.g. 5 m conveyor distance = double load, 20 m conveyor distance = half load.

Maximum conveyor distances 25 - 30 m. The installation of guide plates is recommended as of 15 m (see page 61).

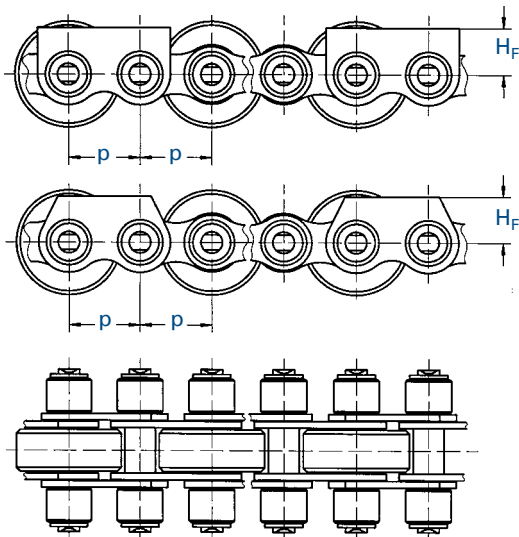

548 SF

513 SF

The guide plate distance is an even multiple of the pitch, e.g. $T = 4 p$

Chain	p		H _F	
No.	mm	mm	mm	
513 SF	19,05	12,6	± 0,1	
548 SF	25,40	18,0	± 0,1	

Design with guide plates

Axial profile of sprockets for accumulator chains

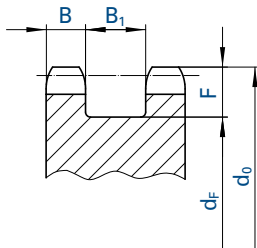

$$d_F = d_0 - 2 F$$

$$F = \frac{d}{2} + 2$$

Chain	B	B ₂	F
No.	mm	mm	mm
T 455	5,2	15,3	8,0
513 SF	10,6	20,8	16,0
D 513 SF	10,6	42,0	16,0
T 513 SF	10,8	28,2	16,0
548 SF	12,0	33,0	22,0
D 548 SF	12,0	66,0	22,0
T 548 SF	15,8	48,0	22,0
722 SF	10,6	20,8	16,0
728 SF	12,0	33,0	27,0

Sprockets are available for all accumulator chains.

Chain guide for accumulator chains

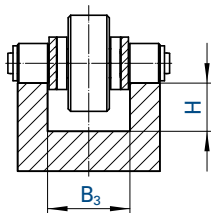

Chain	B ₃	F
No.	mm	mm
513 SF	20,8	15,0
513 SFK	20,8	15,0
D 513 SF	40,5	15,0
548 SF	33,0	20,0
D 548 SF	66,0	20,0
722 SF	20,8	15,0
728 SF	33,0	27,0

Different designs, roller diameters and pin lengths are available on request



Accumulator chain with AFS-Clip



Omega drive

Accumulator chain AFS – optimal equipment and finger protection

- Prevents small parts from entering into gaps between conveyor rollers
- Increases operational safety
- Covers danger zone in chain deflection range as well
- Both-way deflections (e.g. with omega drives) still possible
- Can be supplied with different diameters and in various materials

Accumulator chains have a so-called conveyor roller on every other pitch. This is required for the transport of the material to be conveyed and ensures the smoothly running of the chain under the goods during accumulation without damaging them.

The chain link joint between the conveyor rollers constitutes a larger gap into which small parts might enter and then damage the chain or the entire system. Depending on the respective

application area, there is also the danger of fingers reaching into these gaps and thus causing injuries.

An accumulator chain with AFS clip ensures a trouble-free operation of conveyance and assembly systems and contributes considerably to operational safety according to effective machinery directives. For due to the flat design of the AFS clip the gap between the conveyor rollers is completely closed. The two-piece clip is mounted by snapping it onto the chain bushing of the inner link also covering the danger zone in the deflection range of the chain. Therefore both-way deflections, e.g. with omega drives, are still possible.

Depending on the respective application, conveyor rollers with different diameters made of various materials (steel, PA 6.6, PA 12 antistatic) can be supplied.

Accumulator chains can also be supplied in stainless steel, as maintenance-free MARATHON chains as well as in duplex or triplex designs.

AFS-Clips – Retrofitting for safety

For standard accumulator chains with conveyor roller diameters of 24 mm and 26 mm



The two-piece clip is mounted by simply snapping it onto the chain bushing of the inner link.

Due to the flat design of the AFS clip the construction-related gap between the conveyor rollers is completely closed. Hence equipment and finger protection is considerably increased.

Retrofitting of this innovative and easily mountable protective safety feature is possible for every standard accumulator chain with conveyor roller diameters of 24 mm and 26 mm. The two-piece clip is mounted by simply snapping it onto the chain bushing of the inner link. No tools are necessary since the pieces can easily be snapped directly onto the chain from the

top. The correct position is guaranteed by a clear locking in place of the clip during mounting. Owing to its innovative hinge system it also covers the danger zone in the deflection range of the chain. Therefore both-way deflections, e.g. for omega drives, are possible.

Thus the wear-resistant AFS clips ensure a trouble-free operation of conveyance and assembly systems and contribute considerably to operational safety according to effective machinery directives.



ATC chains

High storage capacity in the tightest of spaces

WIPPERMANN ATC chains have been developed as tool storage and organizing devices for NC/CNC machining centres as well as for storage chains used to construct e.g. reamers or milling tools. The chains are manufactured individually to customers' requirements. The two standard types No. 320 and No. 340 are the basic chains, which can be customised for most applications with tool holding attachments such as SK, HSK and Capto®*.

For small tool attachment systems and other applications ATC chains can be individually developed based on standard roller chains or on a combination of roller chains and double pitch chains respectively.

The chains are designed for holding tools and are used when constructions with e.g. discs are insufficient. Depending on the respective construction (e.g. in case of a meander-shaped design) the chain has a storage capacity of more than 100 tools in one system. ATC chains thus allow for higher storage capacity under the same limited spatial conditions.

Design advantages

- The holding devices in the taper area are fitted with swell-resistant, low-wear plastic inserts ensuring a smooth mounting of the conical surface.
- The axial fixtures have been developed in a way that various dimensions are possible in one chain, e.g. DIN, ISO, ANSI as well as BT. Merely the ball holders must be exchanged respectively.
- By means of several position threads tool orientation may be selected (90° or 75°). Depending on the customers' requirements the axial force can be 100N - 500N.

* registered trademark of Sandvik Coromant

Application examples

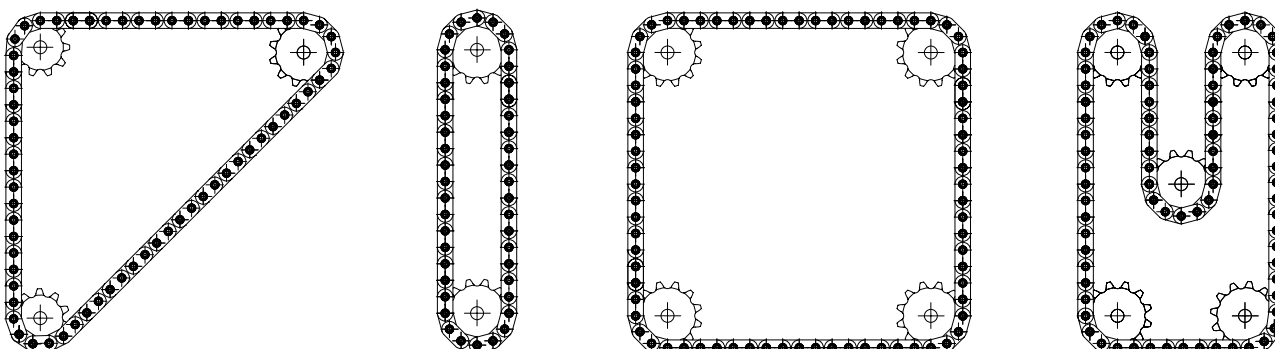



Tool securing

The simplest axial securing of tool holding attachments is achieved by means of ball locking devices with pre-stressed springs. With SK attachments the ball holders can be exchanged in the chain depending on the clamping spigot e.g. when changing from DIN to ANSI spigots.

However, this kind of axial securing is only advisable for standing or hanging arrangements with lightweight tools. Depen-

ding on customers' requests pulling forces can be adjusted between 100N and 500N according to the respective system.

It is recommended to secure the tool holding attachments with locking pins, which are unlocked by means of pneumatic or hydraulic cylinders from the rear.

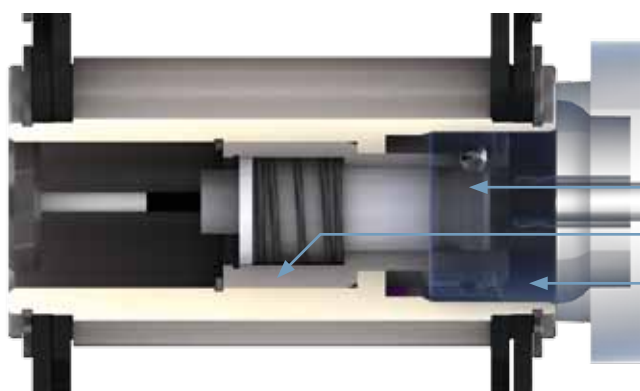

HSK 100

- Ball bushing
- Locking pin with ball locking device
- Tool holding device directly mounted without plastic bushing

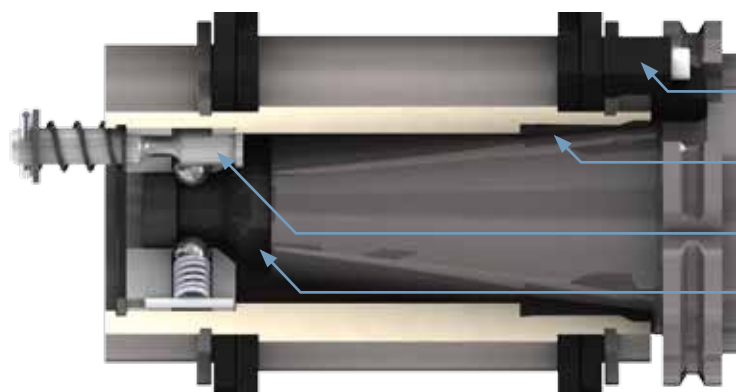

SK 50

- Tool positioner
- Swell-resistant, low-wear plastic insert
- Locking pin with ball locking device
- Pulling taper

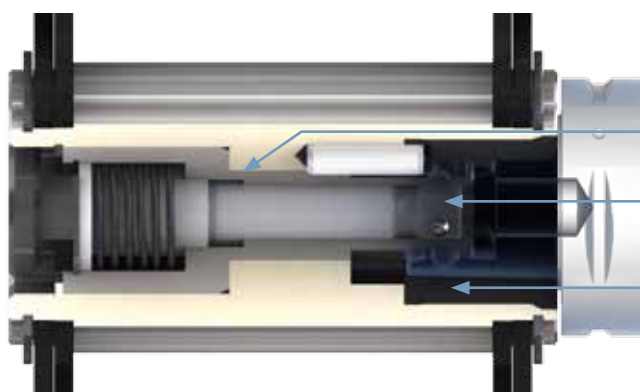

Capto[®]*-C8

- Ball bushing
- Locking pin with ball locking device
- Swell-resistant, low-wear plastic insert

* registered trademark of Sandvik Coromant

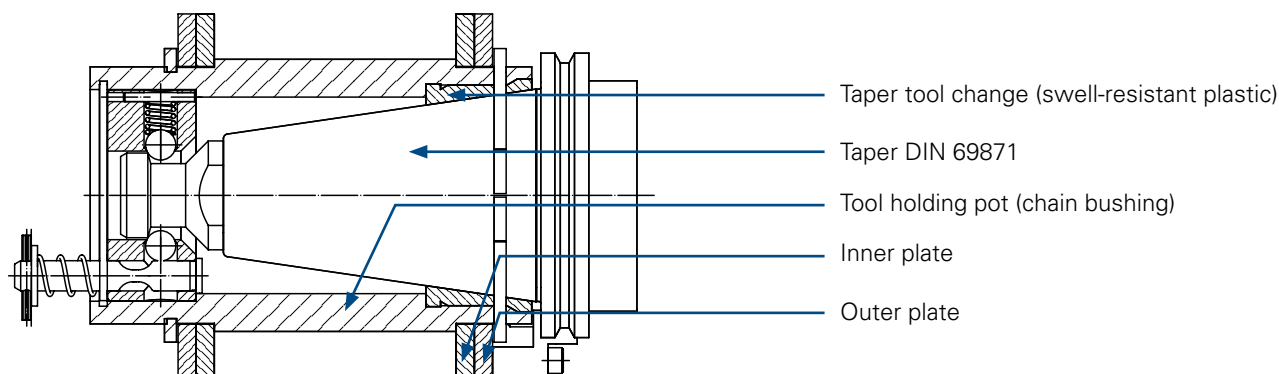
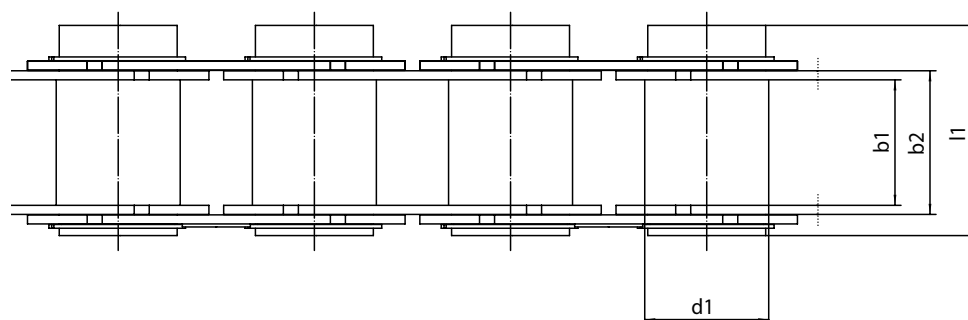
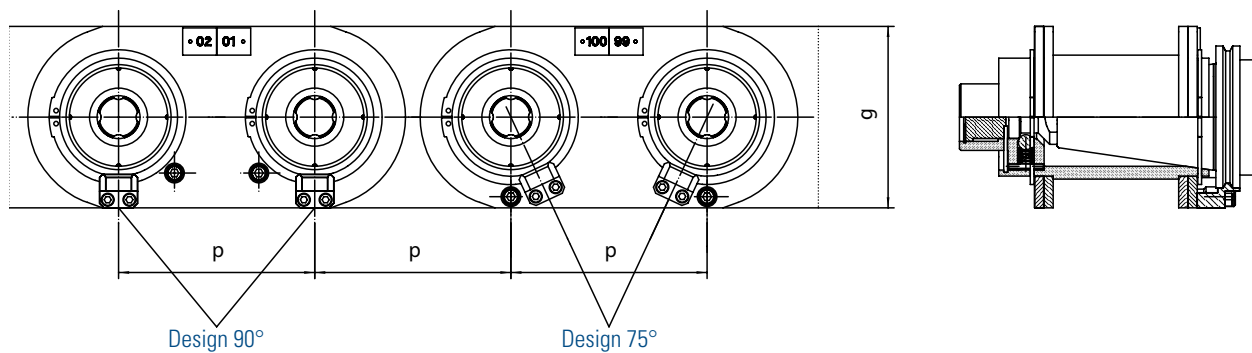

Chain		Pitch	Inner width	Inner link width	Bushing \varnothing	Plate height	Width over bushing	Projection over connecting link	Taper design DIN 69871	Pulling taper				Bearing area	Breaking load	Weight per tool holding attachment
No.	Ind.	p min.	b_1 min.	b_2 max.	d_1 max.	g max.	l_1 max.	k max.		ISO 7388	DIN 69872	MAST BT	ANSI Norm 45°	g	F_B min.	kg
320	²⁸	95	60,00	69,00	60,00	82,00	103,00	21,6	SK 40		X	X	X	4,74	90 000	2,0
340	²⁸	120	80,00	93,00	90,00	120,00	146,00	25,0	SK 50	X	X	X	X	9,60	190 000	5,3

²⁸ larger pitch available on request

Can also be supplied for tool holding attachments HSK, HSZ and HSEZ!

**Customer information**

Customer number Company

Contact person Ms. Mr.

Street

Postcode/zip code City

Telephone Telefax

Product information

Tool holding attachments Type SK according to DIN EN ISO

Type HSK according to DIN EN ISO

Type Capto®* Type

Others

Pulling taper according to ISO 7388 DIN 69872 Mast-BT ANSI 45

Chain pitch mm Traversing speed m/s

Chain type 320 nominal pitch $P_{min.} = 95\text{mm}$; Chain type 340 nominal pitch $P_{min.} = 120\text{mm}$ up to 175 mm (other pitches and sizes on request)

Max. tool weight kg Max. tool diameter mm

Max. tool length mm Max. moment of tilt Nm

Tool axis arrangement (in tool holder) horizontal vertical standing hanging

Tool holder arrangement horizontal vertical

Number of tool pots pcs Distance with empty pots $T = \dots \times P$

For tools with larger diameters (e.g. milling heads) it is advantageous to choose a shorter chain pitch and only use every second or third tool pot since this will increase the smoothness of the chain drive.

- Pick-up position of gripper on sprocket Z1 straight section
- Position number Mechanical tool locking

Retention force of tool securing N

Angular position of tools in chain

e.g. in case of Z1-12 the demounting angle is 15°

in case of demounting on straight section it is 90°

Locking with spring force N

Information on sprockets

	Teeth	Bore Ø	Groove according to DIN 6885
Drive pinion Z1			
Deflection Z2			
Deflection Z3			
Deflection Z4			
Deflection Z5			

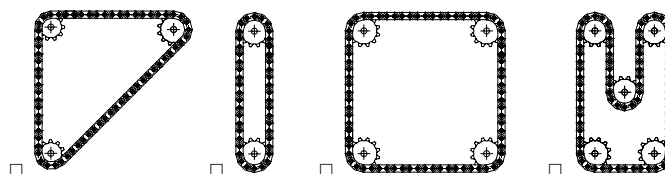
ATC chain arrangement**Additional information**

* registered trademark of Sandvik Coromant

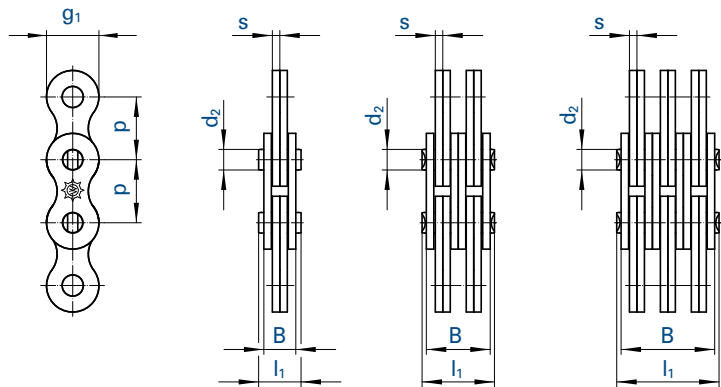

Abstract from ISO 4347

Chains may be assembled with chain parts according to ISO 606. Therefore the actual pitch may deviate from the nominal pitch. The permissible length deviation refers to the length specification of the manufacturer and is $\pm 0,25\%$ under the measuring force.

Chain			Nominal pitch		Lacing	Width over		Pin \varnothing d_2 max.	Plate		Effective length over 100 x pitch* mm	Bearing area $f \approx$ cm ²	Breaking load ISO F_B min. kN	Weight $q \approx$ kg/m
No.	Ind.	ISO No.	p			Pins	Plates		thickness s	height g_1 max.				
			mm	inch	l_1 max. mm	B max. mm								
F 122		LL 0822	12,700	1/2	2 x 2	9,0	6,4	4,45	1,55	10,7	1260	0,138	18,0	0,39
F 124		LL 0844	12,700	1/2	4 x 4	15,2	12,8	4,45	1,55	10,7	1260	0,276	36,0	0,74
F 126		LL 0866	12,700	1/2	6 x 6	21,4	19,0	4,45	1,55	10,7	1260	0,414	54,0	1,10
F 152		LL 1022	15,875	5/8	2 x 2	10,0	7,2	5,08	1,65	12,6	1580	0,175	26,0	0,50
F 154		LL 1044	15,875	5/8	4 x 4	17,1	14,5	5,08	1,65	12,6	1580	0,349	50,0	0,96
F 156		LL 1066	15,875	5/8	6 x 6	24,1	21,5	5,08	1,65	12,6	1580	0,524	78,0	1,39
F 192		LL 1222	19,050	3/4	2 x 2	10,7	7,8	5,72	1,83	14,7	1892	0,209	33,0	0,59
F 194		LL 1244	19,050	3/4	4 x 4	18,1	15,2	5,72	1,83	14,7	1892	0,419	66,0	1,15
F 196		LL 1266	19,050	3/4	6 x 6	25,4	22,6	5,72	1,83	14,7	1892	0,628	99,0	1,70
F 194 S		-	19,050	3/4	4 x 4	21,0	18,6	5,98	2,25	14,7	1905	0,515	76,5	1,40
F 196 S		-	19,050	3/4	6 x 6	31,5	27,8	5,98	2,25	14,7	1905	0,772	115,0	2,10
F 252		LL 1622	25,400	1	2 x 2	17,2	12,8	8,28	3,00	21,1	2532	0,500	70,0	1,56
F 254		LL 1644	25,400	1	4 x 4	29,3	25,6	8,28	3,00	21,1	2532	0,994	140,0	3,04
F 256		LL 1666	25,400	1	6 x 6	41,3	37,5	8,28	3,00	21,1	2532	1,490	210,0	4,53
F 312		LL 2022	31,750	1 1/4	2 x 2	20,3	16,0	10,19	3,75	25,4	3170	0,750	105,0	2,01
F 314		LL 2044	31,750	1 1/4	4 x 4	36,5	32,0	10,19	3,75	25,4	3170	1,500	210,0	3,93
F 316		LL 2066	31,750	1 1/4	6 x 6	51,5	48,0	10,19	3,75	25,4	3170	2,250	315,0	5,86
F 382		LL 2422	38,100	1 1/2	2 x 2	26,5	21,0	14,63	5,00	33,4	3797	1,460	175,0	4,18
F 384		LL 2444	38,100	1 1/2	4 x 4	46,5	42,0	14,63	5,00	33,4	3797	2,930	350,0	8,48
F 386		LL 2466	38,100	1 1/2	6 x 6	67,5	62,0	14,63	5,00	33,4	3797	4,390	525,0	12,20
F 502		LL 3222	50,800	2	2 x 2	30,5	25,0	17,81	6,00	43,0	5070	2,140	265,0	6,73
F 504		LL 3244	50,800	2	4 x 4	54,5	50,0	17,81	6,00	43,0	5070	4,280	530,0	13,10
F 506		LL 3266	50,800	2	6 x 6	80,5	74,0	17,81	6,00	43,0	5070	6,420	800,0	19,50
F 508		LL 3288	50,800	2	8 x 8	105,5	99,0	17,81	6,00	43,0	5070	8,560	1050,0	25,80
F 501		LL 3110	50,800	2	10 x 10	130,0	123,0	17,81	6,00	43,0	5070	10,850	1330,0	31,56
F 632		LL 4022	63,500	2 1/2	2 x 2	44,7	33,2	22,89	8,00	52,0	6335	3,525	422,0	10,51
F 634		LL 4044	63,500	2 1/2	4 x 4	77,9	65,6	22,89	8,00	52,0	6335	7,050	845,0	20,29
F 636		LL 4066	63,500	2 1/2	6 x 6	111,1	98,0	22,89	8,00	52,0	6335	10,575	1270,0	29,74
F 638		LL 4088	63,500	2 1/2	8 x 8	136,0	130,4	22,89	8,00	52,0	6335	14,100	1690,0	39,30

* Chain length tolerance $\pm 0,25\%$ of uncoiled chain under measuring force.

For ordering examples, end links and connecting pins see page 70.

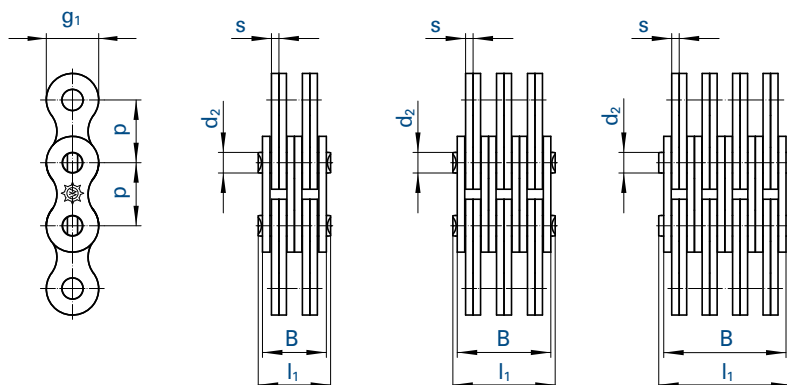

Chain		Nominal pitch		Lacing	Width over		Pin Ø	Plate		Effective length over 100 x pitch*	Bearing area	Breaking load	Weight
⚙️		p			Pins	Plates		thickness	height				
No.	Ind.	mm	inch		l ₁ max.	B max.	d ₂ max.	s	g ₁ max.	f ≈	F _B min.	q ≈	
FU 154		15,875	5/8	4 x 4	17,1	14,5	5,08	1,65	14,4	1596	0,350	52,0	1,2
FU 156		15,875	5/8	6 x 6	24,1	21,5	5,08	1,65	14,4	1596	0,524	78,0	1,8
FU 158		15,875	5/8	8 x 8	30,9	28,0	5,08	1,65	14,4	1596	0,699	102,0	2,3
FU 156 S		15,875	5/8	6 x 6	27,5	25,0	5,08	2,05	14,7	1596	0,625	83,5	2,1
FU 194		19,050	3/4	4 x 4	18,1	15,2	5,72	1,83	16,1	1907	0,419	66,0	1,4
FU 196		19,050	3/4	6 x 6	25,4	22,6	5,72	1,83	16,1	1907	0,628	99,0	2,3
FU 196 S		19,050	3/4	6 x 6	31,7	28,8	6,50	2,35	18,1	1907	0,917	130,0	2,9
FU 254		25,400	1	4 x 4	29,3	25,6	8,28	3,00	23,0	2550	0,994	140,0	3,5
FU 256		25,400	1	6 x 6	41,3	37,5	8,28	3,00	23,0	2550	1,490	210,0	5,0
FU 258		25,400	1	8 x 8	53,1	49,0	8,28	3,00	23,0	2550	1,987	280,0	6,8

* Chain length tolerance ± 0,25 % of uncoiled chain under measuring force.

For ordering examples, end links and connecting pins see page 70.
For information on the selection of chain sizes see pages 116/117.

Leaf chains heavy duty design U according to works-standard

With chains of this type all plates are mounted with a sliding fit and are also secured with laterally attached riveted washers. This design guarantees an even load distribution and reduces the bending load of the pin. These chains have been designed to transport heavy loads under harsh conditions. They are particularly suitable for such applications due to their high fatigue strength.

Chain		Nominal pitch		Lacing	Width over		Pin Ø	Plate		Effective length over 100 x pitch*	Bearing area	Breaking load	Weight
⚙️		p			Pins	Plates		thickness	height				
No.	Ind.	mm	inch		l ₁ max.	B max.	d ₂ max.	s	g ₁ max.	f ≈	F _B min.	q ≈	
F 384 U		38,1	1 1/2	4 x 4	53,2	42,0	14,63	5,00	33,4	3802	2,926	354,0	9,1
F 386 U		38,1	1 1/2	6 x 6	75,2	62,0	14,63	5,00	33,4	3802	4,389	540,0	12,5
F 388 U		38,1	1 1/2	8 x 8	94,2	83,0	14,63	5,00	33,4	3802	5,852	700,0	16,5
F 504 U		50,8	2	4 x 4	60,2	50,0	17,81	6,00	43,0	5073	4,274	530,0	13,5
F 506 U		50,8	2	6 x 6	87,2	74,0	17,81	6,00	43,0	5073	6,412	800,0	20,0
F 508 U		50,8	2	8 x 8	111,2	99,0	17,81	6,00	43,0	5073	8,549	1050,0	26,5
F 501 U		50,8	2	10 x 10	135,0	123,0	17,81	6,00	43,0	5073	10,686	1330,0	33,1
F 634 U		63,5	2 1/2	4 x 4	81,2	70,0	22,89	8,00	52,0	6340	5,494	845,0	19,4
F 636 U		63,5	2 1/2	6 x 6	112,2	101,0	22,89	8,00	52,0	6340	10,990	1270,0	29,1
F 638 U		63,5	2 1/2	8 x 8	146,0	135,0	22,89	8,00	52,0	6340	14,650	1690,0	38,8

* Chain length tolerance ± 0,25 % of uncoiled chain under measuring force.

For ordering examples, end links and connecting pins see page 70.
For information on the selection of chain sizes see pages 116/117.



Inner end link

4 x 4

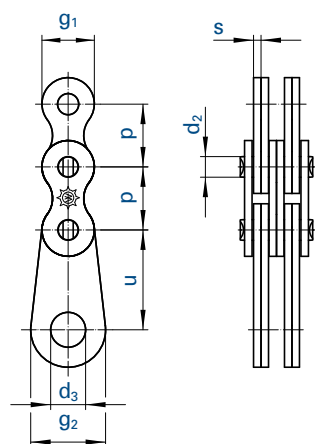

Outer end link

4 x 4

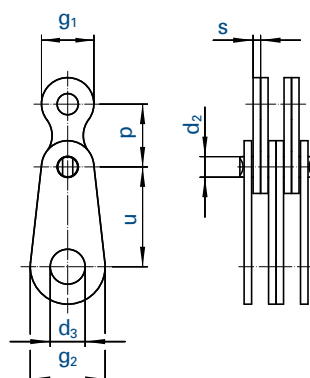

Connecting pin

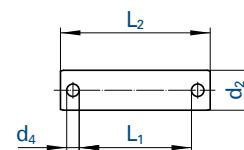

Leaf chains are only supplied with end links on customers' request. The design with either outer or inner end link must be stated in the order.

Design of chain ends:

Only the normal links are counted

- A Both sides with inner end links (uneven number of links)
- B Both sides with outer end links (uneven number of links)
- C One side with inner end link, other side with outer end link (even number of links)
- D One side with inner end link, other side with inner link (even number of links)
- E One side with outer end link, other side with outer link (even number of links)
- F One side with inner end link, other side with outer link (uneven number of links)
- G One side with outer end link, other side with inner link (uneven number of links)
- H Both sides with inner links (uneven number of links)
- I Both sides with outer links (uneven number of links)
- K One side with inner link, other side with outer link (even number of links)

Designation of a leaf chain design A with 25,4 mm pitch, combination 4 x 4, 45 normal links and end links on both sides:
F 254 A x 45

Chain		Nominal pitch		End plates								Connecting pins							
				u	d ₂	d ₃	g ₁	g ₂	s	d ₂	d ₄	2 x 2		4 x 4		6 x 6		8 x 8	
No.	Ind.	mm	inch	mm	mm	mm	mm	mm	mm	mm	mm	mm	mm	mm	mm	mm	mm	mm	mm
F 12		12,700	½	30	4,45	10,0	10,5	20	1,55	4,45	1,6	6,8	13,0	13,6	19,8	20,4	26,6	-	-
F 15		15,875	⅝	30	5,08	10,0	12,5	20	1,70	5,08	1,6	7,4	13,6	14,8	21,0	21,8	28,0	-	-
F 19		19,050	¾	30	5,72	10,0	14,5	20	1,80	5,72	1,6	8,0	14,2	15,4	21,6	22,9	29,1	-	-
F 25		25,400	1	45	8,28	16,0	21,0	35	3,00	8,28	3,4	13,0	23,8	25,9	36,7	38,0	48,8	51,0	61,8
F 31		31,750	1 ¼	45	10,19	16,0	24,5	35	3,80	10,19	3,4	16,4	27,2	32,4	43,2	48,5	59,3	64,8	75,6
F 38		38,100	1 ½	60	14,63	26,0	33,0	50	5,00	14,63	4,2	21,3	33,7	42,4	54,8	63,5	75,9	84,8	97,2
F 50		50,800	2	70	17,81	36,0	43,0	70	6,00	17,81	4,2	25,5	37,9	50,5	62,9	75,5	87,9	100,7	113,0
F 63		63,500	2 ½	90	22,89	45,0	52,0	80	8,00	22,89	5,2	-	-	66,4	86,8	99,6	120,0	132,8	153,2
FU 12		12,700	½	30	4,45	10,0	11,5	20	1,55	4,45	1,6	-	-	13,6	19,8	20,4	26,6	-	-
FU 15		15,875	⅝	30	5,08	10,0	14,5	20	1,70	5,08	1,6	-	-	14,8	21,0	21,8	28,0	28,3	34,5
FU 15 S		15,875	⅝	20	5,08	8,3	14,7	18	2,00	5,08	1,6	-	-	-	30,9	37,5	-	-	-
FU 19		19,050	¾	30	5,72	10,0	15,4	20	1,80	5,72	1,6	-	-	15,4	21,6	22,9	29,1	-	-
FU 19 S		19,050	¾	25	6,50	10,3	18,0	20	2,30	6,50	1,6	-	-	19,6	25,8	29,3	35,5	-	-
FU 25		25,400	1	45	8,28	16,0	21,0	35	3,00	8,28	3,4	-	-	25,9	36,7	38,0	48,8	51,0	61,8
F 38 U		38,100	1 ½	60	14,63	26,0	33,0	50	5,00	14,63	4,2	-	-	48,4	61,0	70,0	82,4	90,8	103,2
F 50 U		50,800	2	70	17,81	36,0	43,0	70	6,00	17,81	4,2	-	-	56,5	68,9	81,5	93,9	106,8	119,2
F 63 U		63,500	2 ½	90	22,89	45,0	52,0	80	8,00	22,89	5,2	-	-	72,4	92,8	105,6	126,0	138,8	159,2

Other dimensions on request.

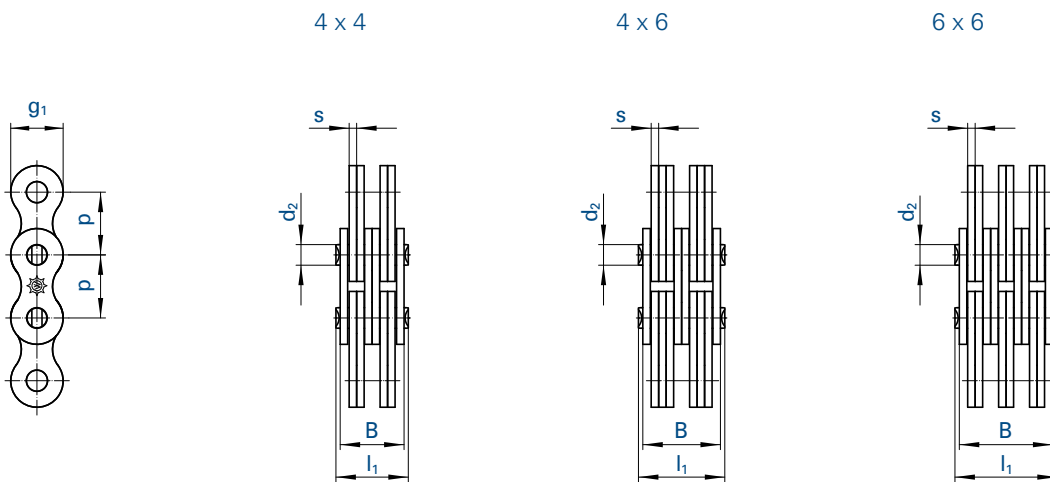

Chain		Nominal pitch	Lacing	Width over		Pin \varnothing	Plate		Effective length over 100 x pitch*	Bearing area	Breaking load ISO	Weight		
No.	Ind.			Pins	Plates		thickness	height						
ISO		p		l_1 max.	B max.	d_2 max.	s	g_1 max.	f \approx	F_B min.	q \approx			
No.	Ind.	No.	mm	inch	mm	mm	mm	mm	mm	mm	cm ²	kN	kg/m	
BL 544		LH 1044	15,875	5/8	4 x 4	22,7	20,0	5,95	2,46	15,1	1592	0,570	66,8	1,86
BL 546		LH 1046	15,875	5/8	4 x 6	27,7	24,8	5,95	2,46	15,1	1592	0,860	66,8	2,32
BL 566		LH 1066	15,875	5/8	6 x 6	32,1	29,7	5,95	2,46	15,1	1592	0,860	100,2	2,77
BL 844		LH 1644	25,400	1	4 x 4	37,9	33,2	9,53	4,06	24,0	2544	1,490	169,0	4,72
BL 846		LH 1646	25,400	1	4 x 6	46,1	41,4	9,53	4,06	24,0	2544	2,230	169,0	5,88
BL 866		LH 1666	25,400	1	6 x 6	54,4	49,4	9,53	4,06	24,0	2544	2,230	253,6	7,04

* Chain length tolerance $\pm 0,25$ % of uncoiled chain under measuring force.

For a pre-selection of leaf chains see page 116/117.

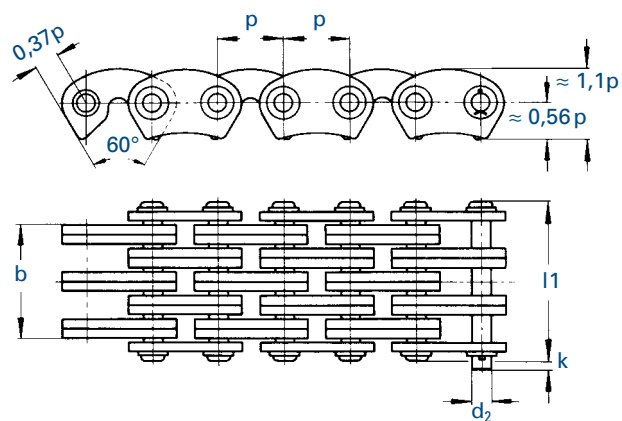

Outer guide system

Chain		Pitch	Lacing	Working width	Overall width	Pin \emptyset	Projection over connecting link	Bearing area	Breaking load	Weight
		p		b min.	l_1 max.	d_2 max.	k	f	F_B min.	q \approx
No.	Ind.	mm		mm	mm	mm	mm		kN	kg/m
1110		10,0	1 x 2	9,6	17,6	3,15	1,6	0,20	11,0	0,64
1112		10,0	2 x 3	16,0	24,1	3,15	1,6	0,29	17,0	0,93
1114		10,0	4 x 5	28,9	37,1	3,15	1,6	0,49	28,0	1,56
1115		10,0	5 x 6	35,2	43,4	3,15	1,6	0,59	34,0	1,88

Inverted tooth chain sprockets on request.

When ordered by length in metres, the chain will contain the next higher even number of links with a connecting pin. When ordered by number of links, the chain will be supplied with an uneven number of links and include a single cranked link riveted into the chain as well as a connecting pin.

Connecting links: According to ISO (...)



No. 10
Connecting pin



No. 52
Cranked three-joint connecting link



No. 53
Straight two-joint connecting link

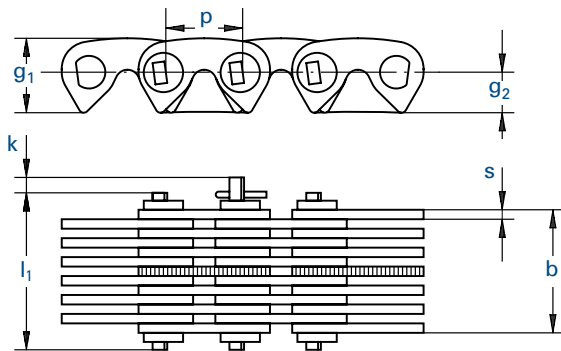

Inner guide system (J)

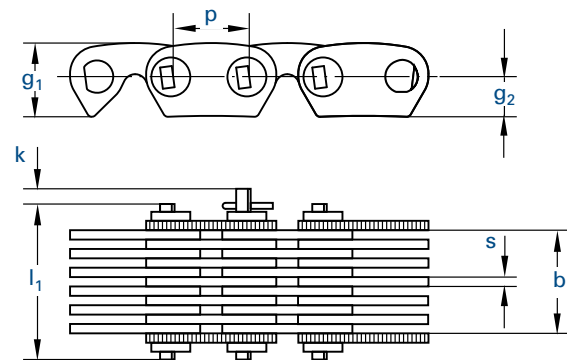

Outer guide system (A)

Chain		Pitch	Working width	Overall width	Plate height		Plate thickness	Projection over connecting link	Number of rows*	Breaking load	Tooth width	Weight
⚙		p	b min.	l ₁ max.	g ₁ max.	g ₂	s	k	RZ	F _B min.		q ≈
No.	Ind.	mm	mm	mm	mm	mm	mm	mm		kN	mm	kg/m
06-015A		9,525	12,5	20,0	9,2	5,2	1,50	2,0	10,0	12,1	11,5	0,80
06-020A		9,525	17,2	24,5	9,2	5,2	1,50	2,0	13,0	14,8	16,0	1,00
06-025J		9,525	26,6	31,0	9,2	5,2	1,50	2,0	17,0	22,9	30,0	1,10
06-030J		9,525	33,0	37,1	9,2	5,2	1,50	2,0	21,0	28,3	35,0	1,40
06-035J		9,525	39,1	43,5	9,2	5,2	1,50	2,0	25,0	33,7	40,0	1,70
08-015A		12,700	12,5	21,5	12,3	6,7	1,50	2,5	10,0	16,0	11,5	1,00
08-020A		12,700	17,2	26,0	12,3	6,7	1,50	2,5	13,0	19,6	16,0	1,20
08-025J		12,700	26,6	32,5	12,3	6,7	1,50	2,5	17,0	30,3	30,0	1,40
08-030J		12,700	33,0	39,0	12,3	6,7	1,50	2,5	21,0	37,4	35,0	1,80
08-035J		12,700	39,1	45,0	12,3	6,7	1,50	2,5	25,0	44,6	40,0	2,10
08-050J		12,700	51,6	58,0	12,3	6,7	1,50	2,5	33,0	58,9	55,0	2,80
08-065J		12,700	64,2	69,8	12,3	6,7	1,50	2,5	41,0	73,1	70,0	3,50
10-025J		15,875	27,0	33,0	15,4	8,4	2,00	3,0	13,0	39,7	30,0	1,90
10-035J		15,875	35,5	41,5	15,4	8,4	2,00	3,0	17,0	52,0	40,0	2,50
10-040J		15,875	43,7	49,5	15,4	8,4	2,00	3,0	21,0	64,2	45,0	3,00
10-050J		15,875	52,0	58,0	15,4	8,4	2,00	3,0	25,0	76,5	55,0	3,60
10-065J		15,875	69,0	75,4	15,4	8,4	2,00	3,0	33,0	100,9	70,0	4,80
12-035J		19,050	35,5	43,0	18,5	10,1	2,00	3,5	17,0	65,0	40,0	2,90
12-040J		19,050	44,0	51,0	18,5	10,1	2,00	3,5	21,0	80,3	45,0	3,60
12-050J		19,050	52,0	59,0	18,5	10,1	2,00	3,5	25,0	95,6	55,0	4,30
12-065J		19,050	68,6	76,0	18,5	10,1	2,00	3,5	33,0	126,2	70,0	5,70
12-075J		19,050	77,0	84,0	18,5	10,1	2,00	3,5	37,0	141,5	80,0	6,40
16-050J		25,400	53,0	61,0	25,0	13,1	3,00	4,0	17,0	126,4	55,0	5,90
16-065J		25,400	65,0	73,0	25,0	13,1	3,00	4,0	21,0	156,1	70,0	7,30
16-075J		25,400	77,5	85,5	25,0	13,1	3,00	4,0	25,0	185,9	80,0	8,70
16-100J		25,400	103,0	111,0	25,0	13,1	3,00	4,0	33,0	245,4	105,0	11,40
16-125J		25,400	127,0	135,0	25,0	13,1	3,00	4,0	41,0	304,9	130,0	14,20
24-065J		38,100	65,5	77,5	37,0	20,1	3,00	6,0	21,0	232,0	75,0	10,80
24-075J		38,100	78,0	90,0	37,0	20,1	3,00	6,0	25,0	276,2	85,0	12,90
24-100J		38,100	103,0	115,0	37,0	20,1	3,00	6,0	33,0	364,6	110,0	17,00
24-125J		38,100	127,5	139,5	37,0	20,1	3,00	6,0	41,0	453,0	135,0	21,10
24-150J		38,100	153,0	165,0	37,0	20,1	3,00	6,0	49,0	541,4	160,0	25,20
32-100J		50,800	104,5	117,5	49,2	26,8	4,00	7,0	25,0	478,1	110,0	22,60
32-115J		50,800	121,2	135,0	49,2	26,8	4,00	7,0	29,0	554,8	125,0	26,20
32-135J		50,800	138,0	151,0	49,2	26,8	4,00	7,0	33,0	631,1	145,0	29,80
32-150J		50,800	154,7	167,7	49,2	26,8	4,00	7,0	37,0	707,6	160,0	33,50
32-180J		50,800	188,1	201,1	49,2	26,8	4,00	7,0	45,0	860,6	190,0	40,70

* Plates on one pivot pin

Inverted tooth chain sprockets on request.

When ordered by length in metres, the chain will contain the next higher even number of links with a connecting pin. For this type of inverted tooth chain no cranked links are available.

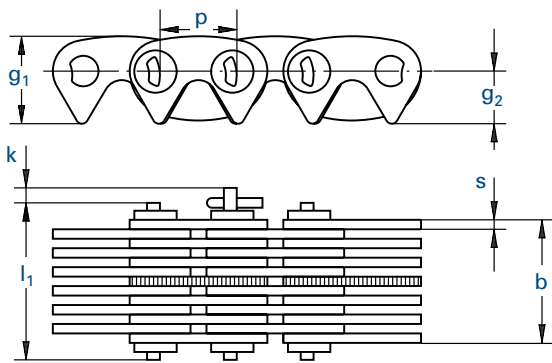
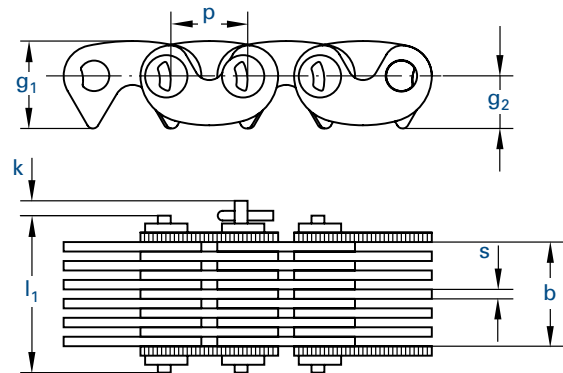

Inner guide system (J)

Outer guide system (A)

Chain		Pitch	Working width	Overall width	Plate height		Plate thickness	Projection over connecting link	Number of rows*	Breaking load	Tooth width	Weight
⚙		p	b min.	l ₁ max.	g ₁ max.	g ₂	s	k	RZ	F _B min.		q ≈
No.	Ind.	mm	mm	mm	mm	mm	mm	mm		kN	mm	kg/m
HD 06-015A		9,525	12,5	19,9	10,9	6,7	1,50	2,0	10,0	14,5	11,5	0,90
HD 06-020A		9,525	17,2	24,5	10,9	6,7	1,50	2,0	13,0	17,7	16,0	1,10
HD 06-025J		9,525	26,6	30,8	10,9	6,7	1,50	2,0	17,0	27,4	30,0	1,40
HD 06-030J		9,525	32,9	37,1	10,9	6,7	1,50	2,0	21,0	33,9	35,0	1,70
HD 06-040J		9,525	39,1	43,3	10,9	6,7	1,50	2,0	25,0	40,3	45,0	2,00
HD 06-050J		9,525	51,6	55,8	10,9	6,7	1,50	2,0	33,0	53,2	55,0	2,60
HD 06-065J		9,525	64,2	68,4	10,9	6,7	1,50	2,0	41,0	66,2	70,0	3,30
HD 08-015A		12,700	12,5	21,3	14,5	8,7	1,50	2,5	10,0	20,2	11,5	1,10
HD 08-020A		12,700	17,2	25,9	14,5	8,7	1,50	2,5	13,0	24,7	16,0	1,40
HD 08-025J		12,700	26,6	32,2	14,5	8,7	1,50	2,5	17,0	38,2	30,0	1,80
HD 08-030J		12,700	32,9	38,5	14,5	8,7	1,50	2,5	21,0	47,3	35,0	2,20
HD 08-040J		12,700	39,1	44,7	14,5	8,7	1,50	2,5	25,0	56,3	45,0	2,60
HD 08-050J		12,700	51,6	57,2	14,5	8,7	1,50	2,5	33,0	74,3	55,0	3,40
HD 08-065J		12,700	64,2	69,8	14,5	8,7	1,50	2,5	41,0	92,3	70,0	4,30
HD 08-075J		12,700	76,7	82,3	14,5	8,7	1,50	2,5	49,0	110,3	80,0	5,10
HP 08-100J		12,700	101,7	107,3	14,5	8,7	1,50	2,5	65,0	146,4	105,0	6,70
HD 12-030A		19,050	27,0	38,2	21,0	10,7	2,00	3,5	15,0	59,6	25,0	3,30
HD 12-035J		19,050	35,4	42,4	21,0	10,7	2,00	3,5	17,0	78,0	40,0	3,70
HD 12-040J		19,050	43,7	50,7	21,0	10,7	2,00	3,5	21,0	96,3	50,0	4,50
HD 12-050J		19,050	52,0	59,0	21,0	10,7	2,00	3,5	25,0	114,7	55,0	5,40
HD 12-065J		19,050	68,6	75,6	21,0	10,7	2,00	3,5	33,0	151,4	70,0	7,10
HD 12-085J		19,050	85,3	92,3	21,0	10,7	2,00	3,5	41,0	188,1	90,0	8,90
HD 12-100J		19,050	101,9	108,9	21,0	10,7	2,00	3,5	49,0	224,9	105,0	10,60
HD 12-125J		19,050	126,9	133,9	21,0	10,7	2,00	3,5	61,0	279,9	130,0	13,20
HD 12-150J		19,050	151,8	158,8	21,0	10,7	2,00	3,5	73,0	335,0	155,0	15,80
HD 12-200J		19,050	201,8	208,8	21,0	10,7	2,00	3,5	97,0	445,2	205,0	20,90
HD 16-040J		25,400	40,2	48,2	27,7	14,0	3,00	6,0	13,0	112,1	45,0	5,60
HD 16-050J		25,400	52,6	60,6	27,7	14,0	3,00	6,0	17,0	146,6	55,0	7,30
HD 16-065J		25,400	65,0	73,0	27,7	14,0	3,00	6,0	21,0	181,1	70,0	9,00
HD 16-075J		25,400	77,4	85,4	27,7	14,0	3,00	6,0	25,0	215,6	80,0	10,70
HD 16-100J		25,400	102,1	110,1	27,7	14,0	3,00	6,0	33,0	284,7	105,0	14,10
HD 16-125J		25,400	126,9	134,9	27,7	14,0	3,00	6,0	41,0	353,7	130,0	17,50
HD 16-150J		25,400	151,7	159,7	27,7	14,0	3,00	6,0	49,0	422,7	155,0	21,00
HD 16-200J		25,400	201,2	209,2	27,7	14,0	3,00	6,0	65,0	560,7	205,0	27,80

* Plates on one pivot pin

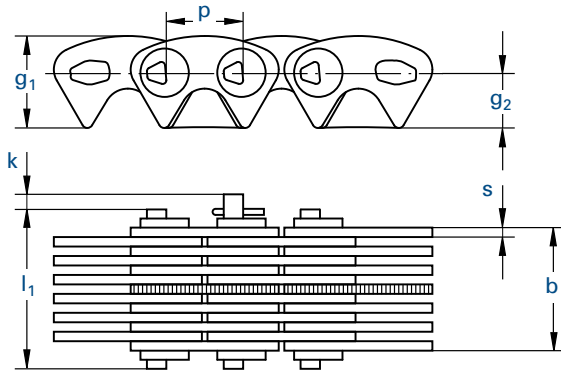
Inverted tooth chain sprockets on request.

When ordered by length in metres, the chain will contain the next higher even number of links with a connecting pin. For this type of inverted tooth chain no cranked links are available.



Inner guide system (J)

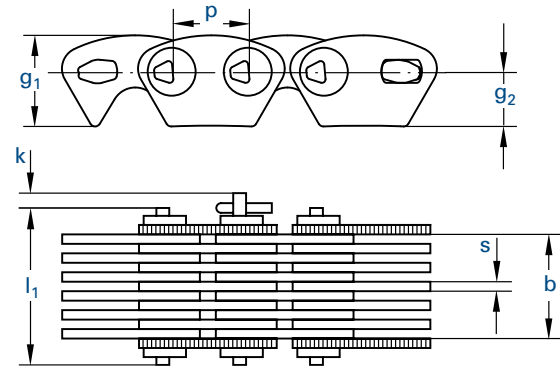

Outer guide system (A)

Chain		Pitch	Working width	Overall width	Plate height		Plate thickness	Projection over connecting link	Number of rows*	Breaking load	Tooth width	Weight
		p	b min.	l_1 max.	g_1 max.	g_2	s	k	RZ	F_B min.		q ≈
No.	Ind.	mm	mm	mm	mm	mm	mm	mm		kN	mm	kg/m
HP 06-015A		9,525	12,5	19,9	11,3	6,8	1,50	2,0	10,0	25,4	11,5	1,00
HP 06-020A		9,525	17,2	24,5	11,3	6,8	1,50	2,0	13,0	30,1	16,0	1,20
HP 06-025J		9,525	26,6	30,8	11,3	6,8	1,50	2,0	17,0	39,3	30,0	1,50
HP 06-030J		9,525	32,9	37,1	11,3	6,8	1,50	2,0	21,0	48,6	35,0	1,80
HP 06-040J		9,525	39,1	43,3	11,3	6,8	1,50	2,0	25,0	57,9	45,0	2,20
HP 06-050J		9,525	51,6	55,8	11,3	6,8	1,50	2,0	33,0	76,4	55,0	2,90
HP 06-065J		9,525	64,2	68,4	11,3	6,8	1,50	2,0	41,0	94,9	70,0	3,60
HP 08-015A		12,700	12,5	21,7	15,2	9,0	1,50	2,5	10,0	27,9	11,5	1,20
HP 08-020A		12,700	17,2	26,3	15,2	9,0	1,50	2,5	13,0	34,1	16,0	1,60
HP 08-025J		12,700	26,6	32,6	15,2	9,0	1,50	2,5	17,0	52,7	30,0	2,00
HP 08-030J		12,700	32,9	38,9	15,2	9,0	1,50	2,5	21,0	65,1	35,0	2,40
HP 08-040J		12,700	39,1	45,1	15,2	9,0	1,50	2,5	25,0	77,5	45,0	2,90
HP 08-050J		12,700	51,6	57,6	15,2	9,0	1,50	2,5	33,0	102,3	55,0	3,80
HP 08-065J		12,700	64,2	70,2	15,2	9,0	1,50	2,5	41,0	127,2	70,0	4,70
HP 08-075J		12,700	76,7	82,7	15,2	9,0	1,50	2,5	49,0	152,0	80,0	5,60
HP 08-100J		12,700	101,7	107,7	15,2	9,0	1,50	2,5	65,0	201,6	105,0	7,50
HP 12-020J		19,050	18,7	25,7	22,5	13,5	2,00	3,5	9,0	55,4	25,0	2,10
HP 12-025J		19,050	27,0	34,0	22,5	13,5	2,00	3,5	13,0	80,1	30,0	3,00
HP 12-035J		19,050	35,4	42,4	22,5	13,5	2,00	3,5	17,0	104,7	40,0	3,90
HP 12-040J		19,050	43,7	50,7	22,5	13,5	2,00	3,5	21,0	129,4	45,0	4,90
HP 12-050J		19,050	52,0	59,0	22,5	13,5	2,00	3,5	25,0	154,0	55,0	5,80
HP 12-065J		19,050	68,6	75,6	22,5	13,5	2,00	3,5	33,0	203,3	70,0	7,60
HP 12-085J		19,050	85,3	92,3	22,5	13,5	2,00	3,5	41,0	252,6	90,0	9,50
HP 12-100J		19,050	101,9	108,9	22,5	13,5	2,00	3,5	49,0	301,9	105,0	11,40
HP 12-125J		19,050	126,9	133,9	22,5	13,5	2,00	3,5	61,0	375,9	130,0	14,10
HP 16-040J		25,400	40,2	48,2	30,0	18,0	3,00	4,0	13,0	152,4	45,0	6,00
HP 16-050J		25,400	52,6	60,6	30,0	18,0	3,00	4,0	17,0	199,4	55,0	7,90
HP 16-065J		25,400	65,0	73,0	30,0	18,0	3,00	4,0	21,0	246,3	70,0	9,70
HP 16-075J		25,400	77,4	85,4	30,0	18,0	3,00	4,0	25,0	293,2	80,0	11,60
HP 16-100J		25,400	102,1	110,1	30,0	18,0	3,00	4,0	33,0	387,0	105,0	15,30
HP 16-125J		25,400	126,9	134,9	30,0	18,0	3,00	4,0	41,0	480,9	130,0	19,00
HP 24-040J		38,100	40,4	52,4	45,0	27,0	3,00	6,0	13,0	236,0	50,0	9,80
HP 24-050J		38,100	52,8	64,8	45,0	27,0	3,00	6,0	17,0	303,4	60,0	11,80
HP 24-065J		38,100	65,2	77,2	45,0	27,0	3,00	6,0	21,0	374,8	75,0	14,60
HP 24-075J		38,100	77,6	89,6	45,0	27,0	3,00	6,0	25,0	446,2	85,0	17,40
HP 24-100J		38,100	102,5	114,5	45,0	27,0	3,00	6,0	33,0	589,0	110,0	22,90
HP 24-125J		38,100	127,3	139,3	45,0	27,0	3,00	6,0	41,0	731,8	135,0	28,50
HP 24-150J		38,100	152,1	164,1	45,0	27,0	3,00	6,0	49,0	874,6	160,0	34,10

* Plates on one pivot pin

Inverted tooth chain sprockets on request.

When ordered by length in metres, the chain will contain the next higher even number of links with a connecting pin. For this type of inverted tooth chain no cranked links are available.



On the following pages, we will only be able to give you a brief overview of the types of chains we can supply since conveyor chains are mostly chains designed for individual applications.

Please send us an enquiry, if you have any queries concerning your specific application.

1. Sprockets for all chains made of steel, cast steel and cast iron, also in split versions and with welded-on segments.

2. Special chains for process engineering equipment of all kind; also made of stainless and heat resistant steel grades.

3. Draw bench chains

- according to DIN 8156 and DIN 8157

4. Conveyor chains / Deep link conveyor chains / Accumulation conveyor chains

- according to DIN 8165 full pin chains and hollow pin chains / type FV
- according to DIN 8165 full pin chains / type M
- according to DIN 8165 hollow pin chains / type MC
- Made to specifications for all applications

5. Moving staircase chains

- according to works-standard and customers' specifications

6. Plate chains for steel plate apron conveyor chains

- according to DIN 8175

7. Plate chains for funiculars

- according to DIN 8176 and DIN Berg 2251

8. Inverted tooth chains according to DIN 8190

- Inverted tooth chains for high speed drives
- Inverted tooth chains made to specifications / Inverted tooth chains for transport

9. Inverted tooth chain sprockets

- according to customers' specifications

10. Sliding rails

11. Cranked link chains

12. Galle chains and sprockets

- according to DIN 8150

We will be happy to assist you with all your problems concerning drives and conveyance!



Chain breaker

Chain breakers

Chain breaking without a breaker tool

The chain breaker ensures a fast and simple breaking of the chain for shortening or for replacing a defective part.

WIPPERMANN offers suitable chain breakers for different roller chain types according to ISO 606 up to a pitch of 1".

No.	suitable for the following chains
KT 455	454, 455, 331, 332, D 455 / ASA 35, 40, 41, 35-2, 40-2
KT 462	331, 332, 17, 18, 385, 460, 461, 462, D 462 / ASA 35, 40, 41, 40-2
KT 501-513	500, 501, 513, D 501, D 513 / ASA 50, 60, 50-2
KT 548	548 / ASA 80

Accessories: Screw A
Screw B
Replacement pin C



Chain puller 125 mm

Chain pullers

Easy mounting of connecting links

Due to the overall weight it is often extremely cumbersome to assemble two chain ends without any tools.

By means of our practical chain puller, the two ends of the chain are pulled together far enough for a connecting link to be mounted without any difficulties.

This chain puller can be supplied in two sizes:

No.	For chain pitches p	Clamping width	Weight
135	12,7 to 19,05 mm	50,0 mm	0,2 kg
180	25,4 to 63,50 mm	125,0 mm	1,0 kg

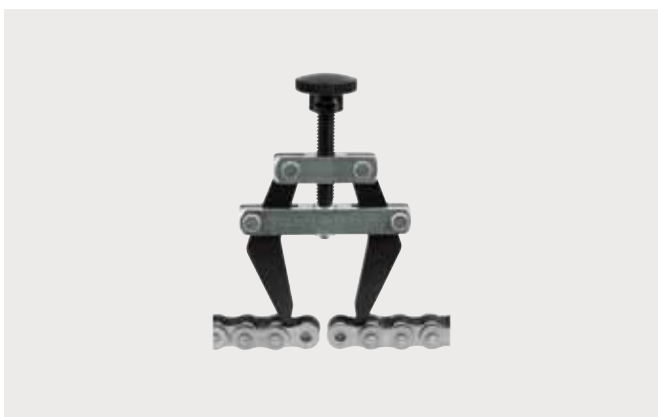

Chain puller 50 mm

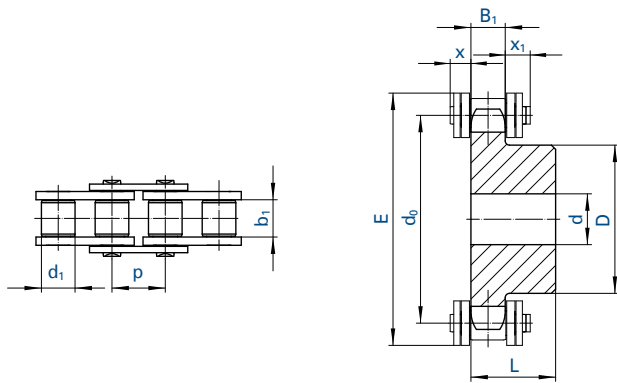

Chain		Pitch	Inner width	Roller Ø	Width over pin	Tooth width	Projection	
ISO		p	b ₁ min.	d ₁ max.	l ₁ max.	B ₁	x max.	x ₁ max.
No.	Ind.	No.	mm	mm	mm	mm	mm	mm
445		04	6,0	2,8	4,0	7,4	2,6	2,5
450		05B-1	8,0	3,0	5,0	8,6	2,8	5,4

Number of teeth	z	445 (04)					450 (05B-1)				
		d ₀	E _{max}	d	D	L	d ₀	E _{max}	d	D	L
	Ind.	mm	mm	mm	mm	mm	mm	mm	mm	mm	mm
10		19,42	25	6	13	10	25,89	34	8	17	12
11		21,30	27	6	14	10	28,40	36	8	18	13
12		23,18	29	6	16	10	30,91	39	8	20	13
13		25,07	31	8	18	10	33,43	41	8	23	13
14		26,96	33	8	20	10	35,95	44	8	25	13
15		28,86	35	8	20	10	38,48	46	8	28	13
16		30,75	36	8	20	13	41,01	49	8	30	14
17		32,65	38	8	20	13	43,54	51	8	30	14
18		34,55	40	8	20	13	46,07	54	8	30	14
19		36,45	42	8	20	13	48,60	57	8	30	14
20		38,36	44	8	20	13	51,14	59	8	30	14
21		40,26	46	8	25	13	53,68	62	8	35	14
22		42,16	48	8	25	13	56,21	64	8	35	14
23		44,06	50	8	25	13	58,75	67	8	35	14
24		45,97	51	8	25	13	61,29	69	8	35	14
25		47,87	53	8	25	13	63,83	72	8	35	14
26		49,78	55	8	30	15	66,37	74	10	40	16
27		51,68	57	8	30	15	68,91	77	10	40	16
28		53,59	59	8	30	15	71,45	79	10	40	16
29		55,49	61	8	30	15	73,99	82	10	40	16
30		57,40	63	8	30	15	76,53	84	10	40	16
32		61,21	67	8	30	15	81,62	90	10	40	16
34		65,03	71	8	30	15	86,70	94	10	40	16
35		66,93	73	8	30	15	89,25	97	10	40	16
36		68,84	75	8	30	15	91,79	100	10	40	16
38		72,66	78	8	30	15	96,88	105	10	40	16
40		76,47	82	8	30	15	101,96	110	10	40	16

* Possibly welded-on hub

Made of steel with a strength of 500 - 600 N/mm². We supply sprockets with custom bore and groove according to specifications. For details on orders and enquiries see page 106. Other sprockets on request.

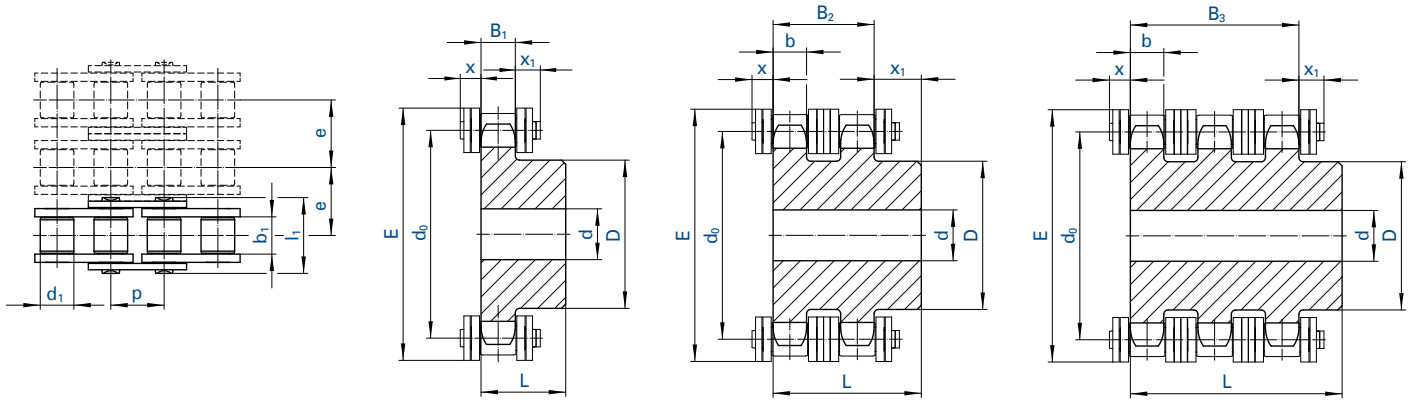

Chain		Pitch	Inner width	Roller Ø	Width over pin	Transverse pitch	Tooth width				Projection		
ISO		p	b ₁ min.	d ₁ max.	l max.	e	B ₁	b	B ₂	B ₃	x max.	x ₁ max.	
No.	Ind.	No.	mm	mm	mm	mm	mm	mm	mm	mm	mm	mm	
455		06B-1	9,525	5,72	6,35	13,5	-	5,3	-	-	-	4,5	7,8
D 455		06B-2	9,525	5,72	6,35	23,8	10,24	-	5,2	15,4	-	4,5	7,8
T 455		06B-3	9,525	5,72	6,35	34,0	10,24	-	5,2	-	25,6	4,5	7,8

Number of teeth		455 (06B-1)					D 455 (06B-2)			T 455 (06B-3)		
z	d ₀	E _{max}	d	D	L	d	D	L	d	D	L	
Ind.	mm	mm	mm	mm	mm	mm	mm	mm	mm	mm	mm	
10	30,82	40	8	20	22	8	20	22	-	-	-	
11	33,81	43	8	22	25	10	22	25	-	-	-	
12	36,80	46	8	25	25	10	25	25	-	-	-	
13	39,80	49	10	28	25	10	28	25	10	28	35	
14	42,81	52	10	31	25	10	31	25	-	-	-	
15	45,81	55	10	34	25	10	34	25	12	34	35	
16	48,82	58	10	37	28	12	37	30	-	-	-	
17	51,84	61	10	40	28	12	40	30	12	40	35	
18	54,85	64	10	43	28	12	43	30	-	-	-	
19	57,87	67	10	45	28	12	46	30	12	46	35	
20	60,89	70	10	46	28	12	49	30	-	-	-	
21	63,91	73	12	48	28	12	52	30	14	52	40	
22	66,93	76	12	50	28	12	55	30	-	-	-	
23	69,95	79	12	52	28	12	58	30	14	58	40	
24	72,97	82	12	54	28	12	61	30	-	-	-	
25	76,00	85	12	57	28	12	64	30	14	64	40	
26	79,02	88	12	60	28	12	67	30	-	-	-	
27	82,05	92	12	60	28	12	70	30	14	70	40	
28	85,07	95	12	60	28	12	73	30	-	-	-	
29	88,10	98	12	60	28	12	76	30	-	-	-	
30	91,12	101	12	60	30	12	79	30	14	79	40	
31	94,15	104	14	65	30	-	-	-	-	-	-	
32	97,18	107	14	65	30	16	80	30	-	-	-	
33	100,20	110	14	65	30	-	-	-	-	-	-	
34	103,23	113	14	65	30	-	-	-	-	-	-	
35	106,26	116	14	65	30	-	-	-	-	-	-	
36	109,29	119	16	70	30	-	-	-	-	-	-	
37	112,31	122	16	70	30	-	-	-	-	-	-	
38	115,34	125	16	70	30	16	90	30	16	90	40	
39	118,37	128	16	70	30	-	-	-	-	-	-	
40	121,40	131	16	70	30	16	90	30	-	-	-	
38	*	115,34	125	19	70	32	19	80	40	-	-	-
45	*	136,55	146	19	70	32	-	-	-	23	90	56
57	*	172,91	182	19	70	32	19	80	40	23	90	56

* Cast iron GG22

Made of steel with a strength of 500 - 600 N/mm². We supply sprockets with custom bore and groove according to specifications. For details on orders and enquiries see page 106. Other sprockets on request.

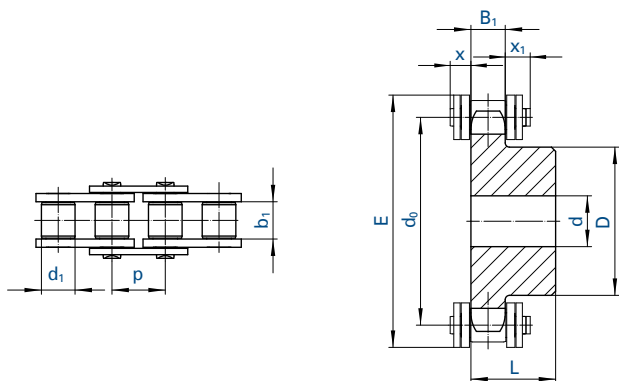

Chain		Pitch	Inner width	Roller Ø	Width over pin	Tooth width	Projection		
ISO		p	b ₁ min.	d ₁ max.	l ₁ max.	B ₁	x max.	x ₁ max.	
No.	Ind.	No.	mm	mm	mm	mm	mm	mm	
331		081	12,7	3,30	7,75	10,2	3,0	3,8	5,3
332		-	12,7	4,88	7,75	11,2	4,5	3,8	5,3

Number of teeth	z	331 (081)					332 / 17 / 18				
		d ₀	E _{max}	d	D	L	d ₀	E _{max}	d	D	L
	Ind.	mm	mm	mm	mm	mm	mm	mm	mm	mm	mm
10		41,10	51	8	28	14	41,10	51	8	28	14
11		45,08	55	8	31	16	45,08	55	8	31	16
12		49,07	59	8	35	16	49,07	59	8	35	16
13		53,07	63	8	39	16	53,07	63	8	39	16
14		57,07	67	8	43	16	57,07	67	8	43	16
15		61,08	71	8	47	16	61,08	71	8	47	16
16		65,10	75	10	50	18	65,10	75	10	50	18
17		69,12	79	10	50	18	69,12	79	10	50	18
18		73,14	84	10	50	18	73,14	84	10	50	18
19		77,16	88	10	50	18	77,16	88	10	50	18
20		81,18	92	10	50	18	81,18	92	10	50	18
21		85,21	96	12	60	20	85,21	96	12	60	20
22		89,24	100	12	60	20	89,24	100	12	60	20
23		93,27	104	12	60	20	93,27	104	12	60	20
24		97,30	108	12	60	20	97,30	108	12	60	20
25		101,33	112	12	60	20	101,33	112	12	60	20
26		105,36	116	16	70	20	105,36	116	16	70	20
27		109,40	120	16	70	20	109,40	120	16	70	20
28		113,43	124	16	70	20	113,43	124	16	70	20
29		117,46	128	16	70	20	117,46	128	16	70	20
30		121,50	132	16	70	20	121,50	132	16	70	20
34		-	-	-	-	-	137,64	148	16	70	20
36		-	-	-	-	-	145,72	156	16	70	25
38		-	-	-	-	-	153,79	165	16	70	25
40		-	-	-	-	-	161,87	173	16	70	25

Made of steel with a strength of 500 - 600 N/mm². We supply sprockets with custom bore and groove according to specifications. For details on orders and enquiries see page 106. Other sprockets on request.

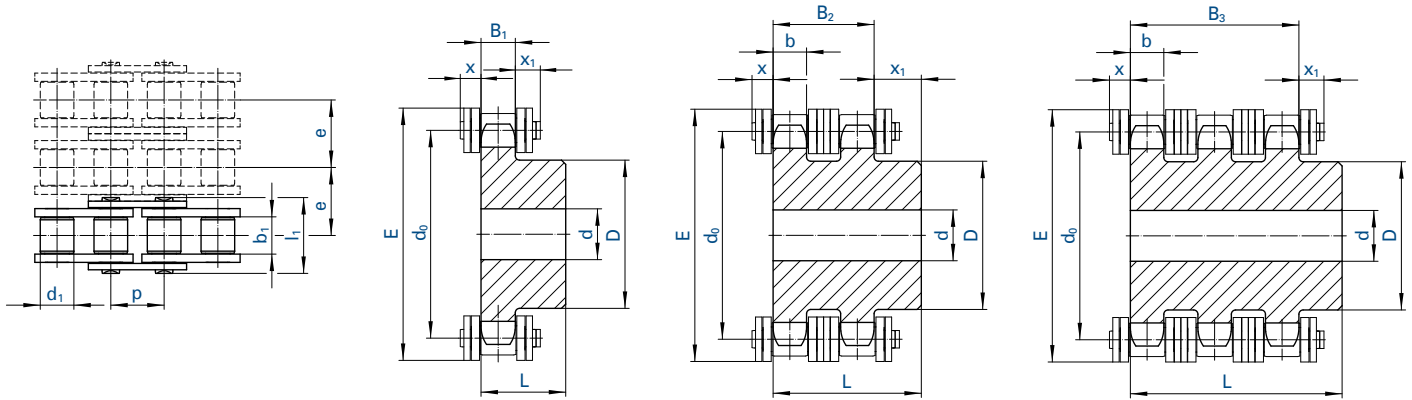

Chain		Pitch	Inner width	Roller Ø	Width over pin	Transverse pitch	Tooth width				Projection		
⚙	ISO	p	b ₁ min.	d ₁ max.	l max.	e	B ₁	b	B ₂	B ₃	x max.	x ₁ max.	
No.	Ind.	No.	mm	mm	mm	mm				mm	mm	mm	
462		08 B-1	12,7	7,75	8,51	17,0	-	7,2	-	-	-	5,4	9,3
D 462		08 B-2	12,7	7,75	8,51	31,0	13,92	-	7,0	21,0	-	5,4	9,3
T 462		08 B-3	12,7	7,75	8,51	44,9	13,92	-	7,0	-	34,9	5,4	9,3

Number of teeth		462 (08B-1)					D 462 (08B-2)			T 462 (08B-3)		
z	d ₀	E _{max}	d	D	L	d	D	L	d	D	L	
	Ind.	mm	mm	mm	mm	mm	mm	mm	mm	mm	mm	
10		41,10	54	10	26	25	10	28	32	-	-	-
11		45,08	58	10	29	25	12	32	35	-	-	-
12		49,07	62	10	33	28	12	35	35	-	-	-
13		53,07	66	10	37	28	12	38	35	14	38	50
14		57,07	70	10	41	28	12	42	35	-	-	-
15		61,08	74	10	45	28	12	46	35	14	46	50
16		65,10	78	12	50	28	14	50	35	-	-	-
17		69,12	82	12	52	28	14	54	35	16	54	50
18		73,14	86	12	56	28	14	58	35	-	-	-
19		77,16	90	12	60	28	14	62	35	16	62	50
20		81,18	94	12	64	28	14	66	35	-	-	-
21		85,21	98	12	68	28	16	70	40	20	70	55
22		89,24	102	12	70	28	16	70	40	-	-	-
23		93,27	106	14	70	28	16	70	40	20	70	55
24		97,30	110	14	70	28	16	75	40	-	-	-
25		101,33	114	14	70	28	16	80	40	20	80	55
26		105,36	118	16	70	30	20	85	40	-	-	-
27		109,40	122	16	70	30	20	85	40	20	85	55
28		113,43	126	16	70	30	20	90	40	-	-	-
29		117,46	130	16	80	30	20	95	40	-	-	-
30		121,50	134	16	80	30	20	100	40	20	100	55
31		125,53	138	16	90	30	-	-	-	-	-	-
32		129,57	142	16	90	30	20	100	40	-	-	-
33		133,61	146	16	90	30	-	-	-	-	-	-
34		137,64	150	16	90	30	-	-	-	-	-	-
35		141,68	154	16	90	30	20	100	40	-	-	-
36		145,72	158	16	90	35	20	110	40	-	-	-
37		149,75	162	16	90	35	-	-	-	-	-	-
38		153,79	166	16	90	35	20	110	40	25	120	55
39		157,83	170	16	90	35	-	-	-	-	-	-
40		161,87	174	16	90	35	20	110	40	-	-	-
38	*	153,79	166	-	-	-	23	90	50	23	100	60
45	*	182,06	195	19	70	40	-	-	-	-	-	-
57	*	230,54	243	19	70	40	23	90	50	23	100	60

* Cast iron GG22

Made of steel with a strength of 500 - 600 N/mm². We supply sprockets with custom bore and groove according to specifications. For details on orders and enquiries see page 106. Other sprockets on request.

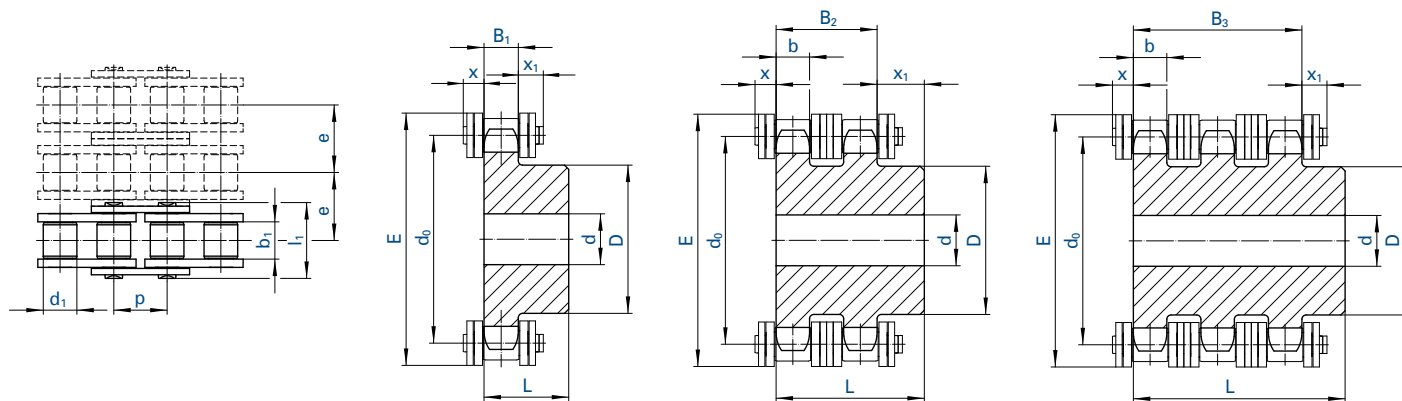

Chain		Pitch	Inner width	Roller Ø	Width over pin	Transverse pitch	Tooth width				Projection		
No.	Ind.	ISO	p	b ₁ min.	d ₁ max.	l max.	e	B ₁	b	B ₂	B ₃	x max.	x ₁ max.
		No.	mm	mm	mm	mm	mm	mm	mm	mm	mm	mm	mm
501		10 B-1	15,875	9,65	10,16	19,6	-	9,1	-	-	-	5,6	9,7
D 501		10 B-2	15,875	9,65	10,16	36,2	16,59	-	9,0	25,5	-	5,6	9,7
T 501		10 B-3	15,875	9,65	10,16	52,8	16,59	-	9,0	-	42,1	5,6	9,7

Number of teeth		501 (10B-1)					D 501 (10B-2)			T 501 (10B-3)		
z	d ₀	E _{max}	d	D	L	d	D	L	d	D	L	
Ind.	mm	mm	mm	mm	mm	mm	mm	mm	mm	mm	mm	
10	51,37	68	10	35	25	12	35	40	-	-	-	
11	56,35	72	12	37	30	14	39	40	-	-	-	
12	61,34	77	12	42	30	14	44	40	-	-	-	
13	66,34	82	12	47	30	14	49	40	16	49	55	
14	71,34	87	12	52	30	14	54	40	-	-	-	
15	76,35	92	12	57	30	14	59	40	16	59	55	
16	81,37	97	12	60	30	16	64	45	-	-	-	
17	86,39	102	12	60	30	16	69	45	16	69	60	
18	91,42	107	14	70	30	16	74	45	-	-	-	
19	96,45	112	14	70	30	16	79	45	16	79	60	
20	101,48	117	14	75	30	16	84	45	-	-	-	
21	106,51	122	16	75	30	16	85	45	20	85	60	
22	111,55	127	16	80	30	16	90	45	-	-	-	
23	116,59	132	16	80	30	16	95	45	20	95	60	
24	121,62	137	16	80	30	16	100	45	-	-	-	
25	126,66	142	16	80	30	16	105	45	20	105	60	
26	131,70	147	20	85	35	20	110	45	-	-	-	
27	136,74	152	20	85	35	20	110	45	20	110	60	
28	141,79	157	20	90	35	20	115	45	-	-	-	
29	146,83	162	20	90	35	20	115	45	-	-	-	
30	151,87	167	20	90	35	20	120	45	20	120	60	
31	156,92	173	20	95	35	-	-	-	-	-	-	
32	161,96	178	20	95	35	20	120	45	-	-	-	
33	167,01	183	20	95	35	-	-	-	-	-	-	
34	172,05	188	20	95	35	-	-	-	-	-	-	
35	177,10	193	20	95	35	-	-	-	-	-	-	
36	182,14	198	20	100	35	-	-	-	-	-	-	
37	187,19	203	20	100	35	-	-	-	-	-	-	
38	192,24	208	20	100	35	20	120	45	25	120	60	
39	197,29	213	20	100	35	-	-	-	-	-	-	
40	202,35	218	20	100	35	20	120	45	-	-	-	
38	192,24	208	-	-	-	29	100	50	31	100	60	
45	227,58	243	19	80	40	-	-	-	-	-	-	
57	288,18	304	23	90	45	29	100	56	31	100	63	

* Cast iron GG22

Made of steel with a strength of 500 - 600 N/mm². We supply sprockets with custom bore and groove according to specifications. For details on orders and enquiries see page 106. Other sprockets on request.

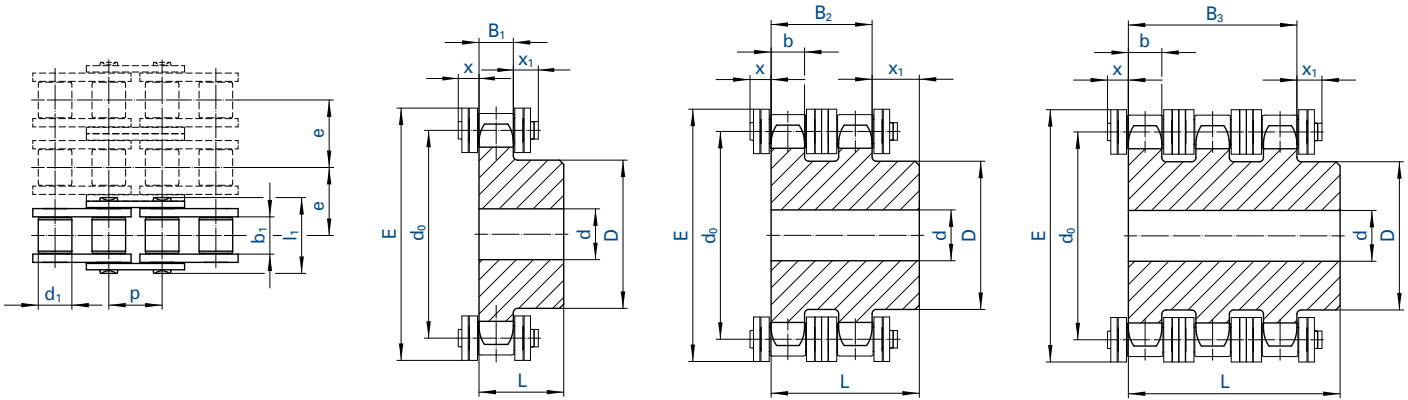

Chain		Pitch	Inner width	Roller Ø	Width over pin	Transverse pitch	Tooth width				Projection		
⚙	ISO	p	b ₁ min.	d ₁ max.	l max.	e	B ₁	b	B ₂	B ₃	x max.	x ₁ max.	
No.	Ind.	No.	mm	mm	mm	mm				mm	mm	mm	
513		12 B-1	19,05	11,68	12,07	22,7	-	11,1	-	-	-	6,4	11,0
D 513		12 B-2	19,05	11,68	12,07	42,2	19,46	-	10,8	30,3	-	6,4	11,0
T 513		12 B-3	19,05	11,68	12,07	61,7	19,46	-	10,8	-	49,8	6,4	11,0

Number of teeth		513 (12 B-1)					D 513 (12 B-2)			T 513 (12 B-3)		
z	d ₀	E _{max}	d	D	L	d	D	L	d	D	L	
	Ind.	mm	mm	mm	mm	mm	mm	mm	mm	mm	mm	
10		61,65	79	12	42	30	12	42	45	-	-	-
11		67,62	85	14	46	35	16	47	50	-	-	-
12		73,6	91	14	52	35	16	53	50	-	-	-
13		79,6	97	14	58	35	16	59	50	20	59	70
14		85,61	103	14	64	35	16	65	50	-	-	-
15		91,62	109	14	70	35	16	71	50	20	71	70
16		97,65	115	16	75	35	20	77	50	-	-	-
17		103,67	121	16	80	35	20	83	50	20	83	70
18		109,71	127	16	80	35	20	89	50	-	-	-
19		115,74	133	16	80	35	20	95	50	20	95	70
20		121,78	139	16	80	35	20	100	50	-	-	-
21		127,82	145	20	90	40	20	100	50	20	100	70
22		133,86	151	20	90	40	20	100	50	-	-	-
23		139,9	157	20	90	40	20	110	50	20	110	70
24		145,95	163	20	90	40	20	110	50	-	-	-
25		151,99	169	20	90	40	20	120	50	20	120	70
26		158,04	176	20	95	40	20	120	50	-	-	-
27		164,09	182	20	95	40	20	120	50	-	-	-
28		170,14	188	20	95	40	20	120	50	-	-	-
29		176,2	194	20	95	40	20	120	50	-	-	-
30		182,25	200	20	95	40	20	120	50	20	120	70
31		188,3	206	20	100	40	-	-	-	-	-	-
32		194,35	212	20	100	40	-	-	-	-	-	-
33		200,41	218	20	100	40	-	-	-	-	-	-
34		206,46	224	20	100	40	-	-	-	-	-	-
35		212,52	230	20	100	40	-	-	-	-	-	-
36		218,57	236	20	100	40	-	-	-	-	-	-
37		224,63	242	20	100	40	-	-	-	-	-	-
38		230,69	248	20	100	40	25	120	50	25	130	70
39		236,74	254	20	100	40	-	-	-	25	130	70
40		242,8	260	20	100	40	25	120	50	-	-	-
38	*	230,69	248	-	-	-	23	130	63	31	140	70
45	*	273,09	290	23	100	56	-	-	-	-	-	-
57	*	345,81	363	29	100	56	29	130	63	39	140	70

* Cast iron GG22

Made of steel with a strength of 500 - 600 N/mm². We supply sprockets with custom bore and groove according to specifications. For details on orders and enquiries see page 106. Other sprockets on request.

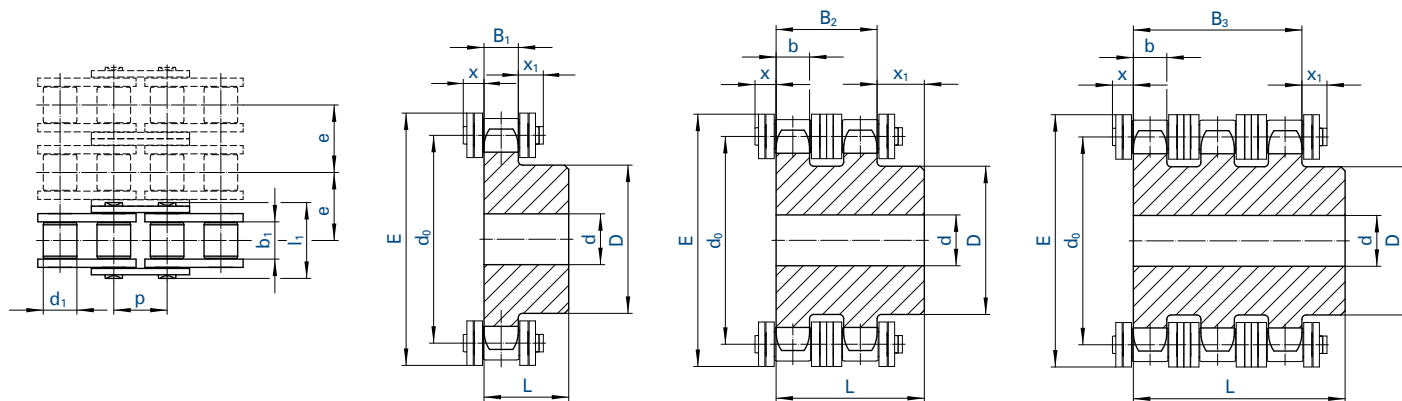

Chain		Pitch	Inner width	Roller Ø	Width over pin	Transverse pitch	Tooth width				Projection		
ISO		p	b ₁ min.	d ₁ max.	l max.	e	B ₁	b	B ₂	B ₃	x max.	x ₁ max.	
No.	Ind.	No.	mm	mm	mm	mm				mm	mm	mm	
548		16 B-1	25,4	17,02	15,88	36,1	-	16,2	-	-	-	10,8	16,2
D 548		16 B-2	25,4	17,02	15,88	68,0	31,88	-	15,8	47,7	-	10,8	16,2
T 548		16 B-3	25,4	17,02	15,88	99,9	31,88	-	15,8	-	79,6	10,8	16,2

Number of teeth		548 (16 B-1)					D 548 (16 B-2)			T 548 (16 B-3)		
z	d ₀	E _{max}	d	D	L	d	D	L	d	D	L	
Ind.	mm	mm	mm	mm	mm	mm	mm	mm	mm	mm	mm	
10	82,2	104	16	55	35	16	56	65	-	-	-	
11	90,16	112	16	61	40	20	64	70	25	64	100	
12	98,14	120	16	69	40	20	72	70	-	-	-	
13	106,14	128	16	78	40	20	80	70	25	80	100	
14	114,15	136	16	84	40	20	88	70	-	-	-	
15	122,17	144	16	92	40	20	96	70	25	96	100	
16	130,2	152	20	100	45	20	104	70	-	-	-	
17	138,23	160	20	100	45	20	112	70	30	112	100	
18	146,27	168	20	100	45	20	120	70	-	-	-	
19	154,32	176	20	100	45	20	128	70	30	128	100	
20	162,37	184	20	100	45	20	130	70	-	-	-	
21	170,42	192	20	110	50	25	130	70	30	130	100	
22	178,48	200	20	110	50	25	130	70	-	-	-	
23	186,54	208	20	110	50	25	130	70	30	130	100	
24	194,6	216	20	110	50	25	130	70	-	-	-	
25	202,66	224	20	110	50	25	130	70	30	130	100	
26	210,72	232	20	120	50	25	130	70	-	-	-	
27	218,79	240	20	120	50	25	130	70	-	-	-	
28	226,86	248	20	120	50	25	130	70	-	-	-	
29	234,93	256	20	120	50	25	130	70	-	-	-	
30	243	265	20	120	50	25	130	70	30	130	100	
32	259,14	281	25	120	50	-	-	-	-	-	-	
34	275,29	297	25	120	50	-	-	-	-	-	-	
35	283,36	305	25	120	50	-	-	-	-	-	-	
36	291,43	313	25	120	50	-	-	-	-	-	-	
38	307,58	329	25	120	50	25	140	70	30	140	100	
40	323,74	345	25	120	50	25	140	70	-	-	-	
45	* 364,12	386	29	125	70	-	-	-	-	-	-	
57	* 461,08	483	34	125	70	39	160	90	44	165	100	

* Cast iron GG22

Made of steel with a strength of 500 - 600 N/mm². We supply sprockets with custom bore and groove according to specifications. For details on orders and enquiries see page 106. Other sprockets on request.

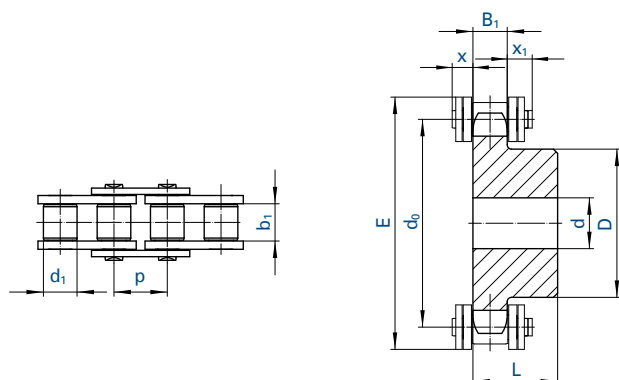

Chain		Pitch	Inner width	Roller Ø	Width over pin	Tooth width	Projection	
ISO		p	b ₁ min.	d ₁ max.	l ₁ max.	B ₁	x max.	x ₁ max.
No.	Ind.	No.	mm	mm	mm	mm	mm	mm
563		20 B-1	31,75	19,56	19,05	43,2	18,5	12,8
596		24 B-1	38,10	25,40	25,40	53,4	24,1	16,0

Number of teeth	563 (20 B-1)						596 (24 B-1)				
	z	d ₀	E _{max}	d	D	L	d ₀	E _{max}	d	D	L
	Ind.	mm	mm	mm	mm	mm	mm	mm	mm	mm	mm
10		102,75	130	20	70	40	123,30	157	20	80	45
11		112,69	139	20	77	45	135,23	169	25	90	50
12		122,67	149	20	88	45	147,21	181	25	102	50
13		132,67	159	20	98	45	159,21	193	25	114	50
14		142,68	169	20	108	45	171,22	205	25	128	50
15		152,71	179	20	118	45	183,25	217	25	140	50
16		162,74	190	25	120	50	195,29	229	25	140	55
17		172,79	200	25	120	50	207,35	241	25	140	55
18		182,84	210	25	120	50	219,41	253	25	140	55
19		192,90	220	25	120	50	231,48	265	25	140	55
20		202,96	230	25	120	50	243,55	277	25	140	55
21		213,03	240	25	140	55	255,63	289	25	150	60
22		223,10	250	25	140	55	267,72	302	25	150	60
23		233,17	260	25	140	55	279,81	314	25	150	60
24		243,25	270	25	140	55	291,90	326	25	150	60
25		253,32	280	25	140	55	303,99	338	25	150	60

* Possibly welded-on hub

Made of steel with a strength of 500 - 600 N/mm². We supply sprockets with custom bore and groove according to specifications. For details on orders and enquiries see page 106. Other sprockets on request.

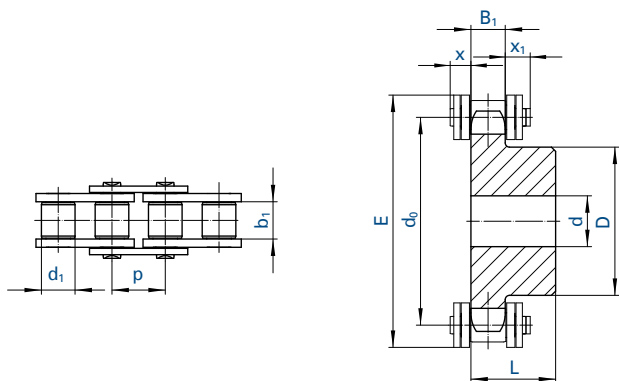

Chain		Pitch	Inner width	Roller Ø	Width over pin	Tooth width	Projection	
⚙		p	b ₁ min.	d ₁ max.	l ₁ max.	B ₁	x max.	x ₁ max.
No.	Ind.	mm	mm	mm	mm	mm	mm	mm
455 RF		9,525	5,72	6,35	13,5	5,3	4,5	7,8
462 RF		12,700	7,75	8,51	17,0	7,2	5,4	9,3
501 RF		15,875	9,65	10,16	19,6	9,1	5,6	9,7
513 RF		19,050	11,68	12,07	22,7	11,1	6,4	11,0
548 RF		25,400	17,02	15,88	36,1	16,2	10,8	16,2

Number of teeth		455 RF					462 RF					501 RF					
		z	d ₀	E _{max}	d	D	L	d ₀	E _{max}	d	D	L	d ₀	E _{max}	d	D	L
	Ind.	mm	mm	mm	mm	mm	mm	mm	mm	mm	mm	mm	mm	mm	mm	mm	mm
13		39,79	49	10	28	25	53,06	66	10	37	28	66,32	82	12	47	30	30
15		45,81	55	10	34	25	61,09	74	10	45	28	76,36	92	12	57	30	30
17		51,83	61	10	40	28	69,11	82	12	52	28	86,39	102	12	60	30	30
19		57,87	67	10	45	28	77,16	90	12	60	28	96,45	112	14	70	30	30
21		63,91	73	12	48	28	85,22	98	14	68	28	106,52	122	16	80	30	30
23		69,65	79	12	52	28	93,27	106	14	70	28	116,58	132	16	80	30	30
25		76,00	85	12	57	28	101,33	114	14	70	28	126,66	142	16	80	30	30

Number of teeth		513 RF					548 RF					
		z	d ₀	E _{max}	d	D	L	d ₀	E _{max}	d	D	L
	Ind.	mm	mm	mm	mm	mm	mm	mm	mm	mm	mm	mm
13		79,59	97	16	58	35	106,12	128	16	78	40	40
15		91,63	109	16	70	35	122,17	144	16	92	40	40
17		103,67	121	16	80	35	138,22	160	20	100	45	45
19		115,75	133	16	80	35	154,33	176	20	100	45	45
21		127,82	145	20	90	40	170,43	192	20	110	50	50
23		139,90	157	20	90	40	186,54	208	20	110	50	50
25		152,00	169	20	90	40	202,66	224	20	110	50	50

Other sprockets made of stainless steel or plastic are available on request.

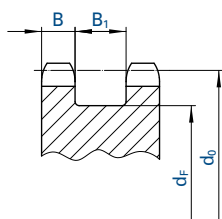

Chain			Pitch	Inner width	Roller Ø
	B ₁	B ₂	p	b ₁ min.	d ₁ max.
No.	mm	mm	mm	mm	mm
513 SF	10,6	20,8	19,05	11,68	12
513 SFK	10,6	20,8	19,05	11,68	12
513 SFV	10,6	20,8	19,05	11,68	12

Number of teeth	PCD	Pilot bore Ø	Hub-Ø between sprockets
z	d ₀		d _F
	mm	mm	mm
15+15	91,62	20	61
17+17	103,67	20	73
19+19	115,73	20	85

Other sprockets made of stainless steel or plastic are available on request.

Sprockets for hollow pin chains 01650

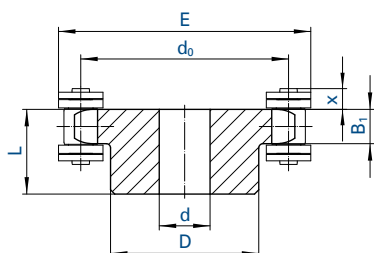

Chain	Pitch	Inner width	Roller Ø	Hollow pin Ø	Width over hollow pin	Plate height	Number of teeth	Sprocket dimensions						
								B ₁	d ₀	d	D	L	E	x
No.	mm	mm	mm	mm	mm	mm		mm	mm	mm	mm	mm	mm	mm
01650	50,8	10	30	8,2	27	26	7	9	117,08	20	80	40	148	10
01650	50,8	10	30	8,2	27	26	12	9	196,28	30	110*	50	227	10
01650	50,8	10	30	8,2	27	26	15	9	244,33	30	120*	50	275	10
01650	50,8	10	30	8,2	27	26	18	9	292,55	30	140*	50	323	10

* welded hub

We supply sprockets with custom bore and groove according to specifications.

Sprockets with integrated ball bearing

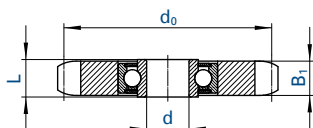

Chain	ISO	Pitch	Inner width	Roller Ø	Width over pin	Jockey sprocket	Number of teeth	d ₀	B ₁	Bearing		Load ratings		
										d + 0,3 + 0,1	L	C dyn.	C ₀ stat.	
No.	No.	mm	inch	mm	mm	No.		mm	mm	mm	mm	kN	kN	
455	06B-1	9,525	3/8	5,72	6,35	13,5	SPR 455	21	63,91	5,3	16	18,3	7,5	4,5
331	081	12,700	1/2	3,30	7,75	10,2	SPR 331	18	73,14	3,0	16	18,3	7,5	4,5
332	-	12,700	1/2	4,88	7,75	11,2	SPR 332	18	73,14	4,5	16	18,3	7,5	4,5
462	08B-1	12,700	1/2	7,75	8,51	17,0	SPR 462	18	73,14	7,2	16	18,3	7,5	4,5
501	10B-1	15,875	5/8	9,65	10,16	19,6	SPR 501	17	86,39	9,1	16	18,3	7,5	4,5
513	12B-1	19,050	3/4	11,68	12,07	22,7	SPR 513	15	91,62	11,1	16	18,3	7,5	4,5
548	16B-1	25,400	1	17,02	15,88	36,1	SPR 548	12	98,14	16,2	20	17,7	10,1	6,3
563	20B-1	31,750	1 1/4	19,56	19,05	43,2	SPR 563	13	132,67	18,5	25	21,0	11,0	7,1

Made of steel with a strength of 500 - 600 N/mm².

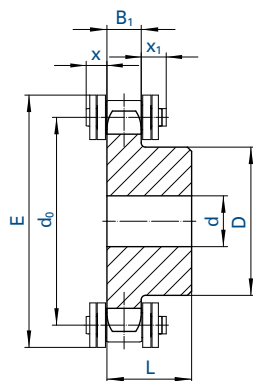

Formula for calculating the PCD:

$$d_0 = \frac{p}{\sin(180^\circ/z)}$$

Formula for calculating the permissible torque:

$$M_{zul.} = \frac{F_B [N] \cdot \frac{d_0 [mm]}{2}}{10 \cdot 1000} [Nm]$$

In all cases where the chain does not wrap around the sprocket, but only contacts it tangentially, the sprocket must be a lantern gear version, because only one tooth at a time meshes with the chain. Therefore the teeth of the sprocket are tempered to reduce wear. Thus roller chains are frequently used as a rack and pinion arrangement.

Rack and pinion arrangements with chains are inexpensive and easy to assemble. A spring clip connecting link or a connecting link with cottered pin is attached to both ends of a pre-stretched chain with an uneven number of links. By means of the connecting links the chain is then mounted to a clamping device. The chain must be supported over the whole length.

Lantern gear	Number of teeth	PCD	Tip circle Ø	Tooth width	Pre-drilled bore	Hub		Roller chain	Pitch	Inner width	Roller Ø
						Ø	length				
	z	d ₀	d _k max.	B ₁	d	D	L		p	b ₁ min.	d ₁ max.
No.		mm	mm	mm	mm	mm	mm	mm	mm	mm	mm
TRB 15462	15	61,08	69,1	6,3	10	30,5	25	462	12,700	7,75	8,51
TRB 17462	17	69,12	77,2	6,3	12	38,5	25	462	12,700	7,75	8,51
TRB 19462	19	77,16	85,3	6,3	12	46,5	25	462	12,700	7,75	8,51
TRB 21462	21	85,21	93,4	6,3	16	54,5	25	462	12,700	7,75	8,51
TRB 23462	23	93,27	101,4	6,3	16	63,0	25	462	12,700	7,75	8,51
TRB 15501	15	76,35	85,9	8,0	12	45,5	25	501	15,875	9,65	10,16
TRB 17501	17	86,39	96,0	8,0	16	55,5	25	501	15,875	9,65	10,16
TRB 19501	19	96,45	106,1	8,0	16	66,0	25	501	15,875	9,65	10,16
TRB 21501	21	106,51	116,2	8,0	16	76,0	25	501	15,875	9,65	10,16
TRB 23501	23	116,59	126,3	8,0	16	86,0	25	501	15,875	9,65	10,16
TRB 15513	15	91,63	103,0	9,5	16	45,0	35	513	19,050	11,68	12,07
TRB 17513	17	103,67	115,1	9,5	20	57,0	35	513	19,050	11,68	12,07
TRB 19513	19	115,74	127,3	9,5	20	69,0	35	513	19,050	11,68	12,07
TRB 21513	21	127,82	139,4	9,5	20	81,0	35	513	19,050	11,68	12,07
TRB 23513	23	139,90	151,5	9,5	20	93,0	35	513	19,050	11,68	12,07
TRB 15548	15	122,17	137,1	14,0	20	75,0	40	548	25,400	17,02	15,88
TRB 17548	17	138,23	153,3	14,0	20	91,0	40	548	25,400	17,02	15,88
TRB 19548	19	154,32	169,5	14,0	20	107,0	40	548	25,400	17,02	15,88
TRB 21548	21	170,42	185,6	14,0	25	123,0	40	548	25,400	17,02	15,88
TRB 23548	23	186,54	201,8	14,0	25	140,0	40	548	25,400	17,02	15,88

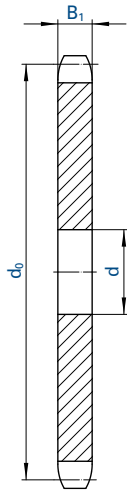

made of steel

Plate thickness = 4 mm
445 (04) as of z = 51
450 (05 B-1) as of z = 46

Number of teeth	z	445 (04)		450 (05 B-1)		455 (06 B-1)	
		$p = 6,0$ mm	$b_1 = 2,7$ mm	$p = 8,0$ mm	$b_1 = 3,0$ mm	$p = 9,525$ mm	$b_1 = 5,720$ mm
		$d_1 = 4,0$ mm	$B_1 = 2,6$ mm	$d_1 = 5,0$ mm	$B_1 = 2,8$ mm	$d_1 = 6,350$ mm	$B_1 = 5,300$ mm
		d_0	d	d_0	d	d_0	d
	Ind.	mm	mm	mm	mm	mm	mm
11		21,30	6	28,40	8	33,81	8
12		23,18	6	30,91	8	36,80	8
13		25,07	8	33,43	8	39,80	8
14		26,96	8	35,95	8	42,81	8
15		28,86	8	38,48	8	45,81	8
16		30,75	8	41,01	8	48,82	10
17		32,65	8	43,54	8	51,84	10
18		34,55	8	46,07	8	54,85	10
19		36,45	8	48,60	8	57,87	10
20		38,36	8	51,14	8	60,89	10
21		40,26	8	53,68	8	63,91	10
22		42,16	8	56,21	8	66,93	10
23		44,06	8	58,75	8	69,95	10
24		45,97	8	61,29	8	72,97	10
25		47,87	8	63,83	8	76,00	10
26		49,78	8	66,37	10	79,02	10
27		51,68	8	68,91	10	82,05	10
28		53,59	8	71,45	10	85,07	10
29		-	-	73,99	10	88,10	10
30		57,40	8	76,53	10	91,12	10
31		-	-	79,08	10	94,15	12
32		61,21	8	81,62	10	97,18	12
33		63,12	8	84,16	10	100,20	12
34		65,03	8	86,70	10	103,23	12
35		66,93	8	89,25	10	106,26	12
36		68,84	8	91,79	10	109,29	12
37		70,75	8	94,33	10	112,31	12
38		72,65	8	96,88	10	115,34	12
39		-	-	99,42	10	118,37	12
40		76,47	8	101,96	10	121,40	12
45		86,01	10	114,68	12	136,55	16
57		108,92	12	145,22	14	172,91	16
65		124,19	14	165,59	16	197,15	20

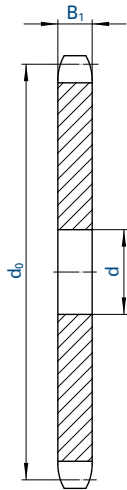

made of steel

Plate thickness = 4 mm
331 (081) as of z = 41

Number of teeth	331 (081)		332		462 (08 B-1)		501 (10 B-1)		
	$p = 12,70$ mm	$b_1 = 3,30$ mm	$p = 12,70$ mm	$b_1 = 4,88$ mm	$p = 12,70$ mm	$b_1 = 7,75$ mm	$p = 15,875$ mm	$b_1 = 9,650$ mm	
	$d_1 = 7,75$ mm	$B_1 = 3,00$ mm	$d_1 = 7,75$ mm	$B_1 = 4,50$ mm	$d_1 = 8,51$ mm	$B_1 = 7,20$ mm	$d_1 = 10,160$ mm	$B_1 = 9,100$ mm	
z	d_0	d	d_0	d	d_0	d	d_0	d	
	Ind.	mm	mm	mm	mm	mm	mm	mm	
11		45,08	8	45,08	8	45,08	10	56,35	10
12		49,07	8	49,07	8	49,07	10	61,34	10
13		53,07	8	53,07	8	53,07	10	66,34	10
14		57,07	8	57,07	8	57,07	10	71,34	10
15		61,08	8	61,08	8	61,08	10	76,35	10
16		65,10	10	65,10	10	65,10	10	81,37	12
17		69,12	10	69,12	10	69,12	10	86,39	12
18		73,14	10	73,14	10	73,14	10	91,42	12
19		77,16	10	77,16	10	77,16	10	96,45	12
20		81,18	10	81,18	10	81,18	10	101,48	12
21		85,21	10	85,21	10	85,21	12	106,51	12
22		89,24	10	89,24	10	89,24	12	111,55	12
23		93,27	10	93,27	10	93,27	12	116,59	12
24		97,30	10	97,30	10	97,30	12	121,62	12
25		101,33	10	101,33	10	101,33	12	126,66	12
26		105,36	12	105,36	12	105,36	16	131,70	16
27		109,40	12	109,40	12	109,40	16	136,74	16
28		113,43	12	113,43	12	113,43	16	141,79	16
29		-	-	117,46	12	117,46	16	146,83	16
30		121,50	12	121,50	12	121,50	16	151,87	16
31		-	-	125,53	12	125,53	16	156,92	16
32		129,57	12	129,57	12	129,57	16	161,96	16
33		133,61	12	133,61	12	133,61	16	167,01	16
34		137,64	12	137,64	12	137,64	16	172,05	16
35		141,68	12	141,68	12	141,68	16	177,10	16
36		145,72	16	145,72	16	145,72	16	182,14	20
37		149,75	16	149,75	16	149,75	16	187,19	20
38		153,79	16	153,79	16	153,79	16	192,24	20
39		157,83	16	157,83	16	157,83	16	197,29	20
40		161,87	16	161,87	16	161,87	16	202,35	20
45		182,06	16	182,06	16	182,06	20	227,58	20
57		230,54	20	230,54	20	-	-	288,18	25
65		-	-	262,87	20	262,87	25	328,58	25

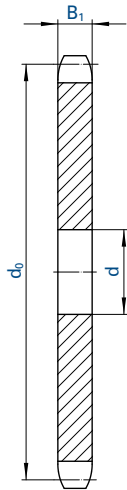

made of steel

Number of teeth z	513 (12 B-1)		548 (16 B-1)		563 (20 B-1)		596 (24 B-1)		
	d_0	d	d_0	d	d_0	d	d_0	d	
	Ind.	mm	mm	mm	mm	mm	mm	mm	
11		67,62	14	90,16	15	112,69	16	135,23	20
12		73,60	14	98,14	15	122,67	20	147,21	20
13		79,60	14	106,14	15	132,67	20	159,21	20
14		85,61	14	114,15	15	142,68	20	171,22	20
15		91,62	14	122,17	15	152,71	20	183,25	20
16		97,65	14	130,20	19	162,74	25	195,29	25
17		103,67	14	138,23	19	172,79	25	207,35	25
18		109,71	14	146,27	19	182,84	25	219,41	25
19		115,74	14	154,32	19	192,90	25	231,48	25
20		121,78	14	162,37	19	202,96	25	243,55	25
21		127,82	16	170,42	20	213,03	25	255,63	25
22		133,86	16	178,48	20	223,10	25	267,72	25
23		139,90	16	186,54	20	233,17	25	279,81	25
24		145,95	16	194,60	20	243,25	25	291,90	25
25		151,99	16	202,66	20	253,32	25	303,99	25
26		158,04	16	210,72	20	263,40	25	-	-
27		164,09	16	218,79	20	273,49	25	328,19	30
28		170,14	16	226,86	20	283,57	25	-	-
29		176,20	16	234,93	20	293,66	25	352,39	30
30		182,25	16	243,00	20	303,75	25	364,50	30
31		188,30	20	251,07	25	313,83	25	-	-
32		194,35	20	259,14	25	323,92	25	388,71	30
33		200,41	20	267,21	25	334,01	25	-	-
34		206,46	20	275,29	25	344,11	25	-	-
35		212,52	20	283,36	25	354,20	25	425,04	30
36		218,57	20	291,43	25	364,29	25	-	-
37		224,63	20	299,51	25	374,38	25	-	-
38		230,69	20	307,58	25	384,48	25	461,38	30
39		236,74	20	315,66	25	394,57	25	-	-
40		242,80	20	323,74	25	404,67	25	485,60	30
45		273,09	25	364,12	25	455,16	30	546,19	30
57		345,81	25	461,08	30	576,35	30	691,63	30
65		394,30	25	525,73	30	657,17	30	788,60	40

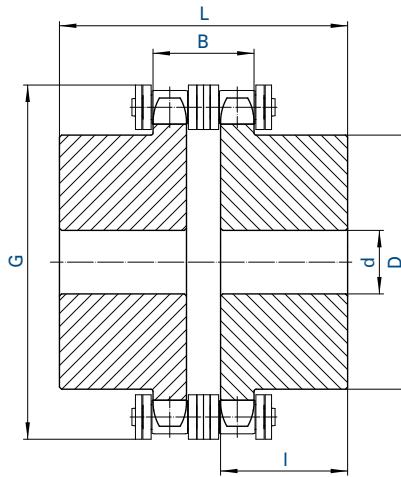

Advantages:

- Elastic torque transmission
- Fast decoupling by simply slackening the chain
- Especially inexpensive

Example:

A 4-cylinder diesel engine with $P = 110 \text{ kW}$ and $n = 1400 \text{ rpm}$ is to be coupled to a three-phase alternator – dynamic load factor 1,5.

The calculation is as follows:

$$1,5 \frac{P}{n} = 1,5 \frac{110}{1400} = 0,1178$$

Select the coupling according to $\frac{P}{n}$ column (see below):
The coupling next in size is No. 548 18.

Dynamic load factors

Load type of driven machines	Drive machines		
	Electric motors	Internal combustion engines	
		4 cylinders and more	less than 4 cylinders
impact-free	1,0	1,5	2,0
low impact	1,5	2,0	2,5
high impact	2,0	2,5	3,0

Coupling		Torque	Flywheel effect	$\frac{P}{n}$	n max.	d min.	D	l	B	Required space		Weight
No.	Ind.	M_d	mD^2							G	L	q max.
		Nm	kgm ²	kW/rpm	rpm	mm	mm	mm	mm	mm	mm	kg/piece
450 18		38	0,000 405	0,0039	8 000	10	38	20	8,2	53,5	43,0	0,41
455 14	*	60	0,000 410	0,0062	6 000	12	33	22	15,2	51,8	49,0	0,41
455 18	*	95	0,001 170	0,0097	6 000	12	45	25	15,2	63,9	55,0	0,78
462 14	*	150	0,001 650	0,0154	5 500	15	44	28	20,7	70,0	63,0	0,93
462 18	*	240	0,004 740	0,0246	5 500	15	60	32	20,7	86,0	71,0	1,83
501 18	*	380	0,013	0,0390	4 500	15	75	35	25,0	107,0	78,0	3,21
513 18	*	600	0,030 100	0,0616	3 000	25	90	40	29,5	126,5	89,5	4,97
513 24	*	940	0,107	0,0965	2 500	25	125	50	29,5	162,5	109,5	10,90
548 18	*	1 480	0,158	0,1519	2 500	30	120	60	46,7	170,0	137,0	12,30
548 24	*	2 350	0,517	0,2413	2 000	30	165	70	46,7	219,0	157,0	27,65
563 22	*	3 700	0,882	0,3798	1 800	40	180	75	53,5	250,0	169,5	37,50
596 18	*	5 800	1,160	0,5954	1 200	50	180	80	70,4	256,0	186,5	43,50
596 24	*	9 200	3,250	0,9445	1 200	50	220	100	70,4	328,0	226,5	78,50
652 22		14 500	7,940	1,4887	1 000	60	260	120	85,6	401,0	272,0	138,00
671 20		23 000	18,710	2,3613	800	75	300	150	105,3	466,0	340,0	231,00

* can also be supplied in maintenance-free MARATHON design. In this case please put MA after the number for the coupling, e.g. 462 14 MA

Couplings are supplied unassembled and the loose chain is enclosed.
Other sprockets, number of teeth, chain types and dimensions on request.

For enquiries and orders please supply the following details:

1. Number of couplings
2. Chain pitch
3. Number of teeth
4. Coupling No. or alternatively torque to be transmitted
5. Bores of coupling halves
6. Groove sizes (for keyways also tightening direction); without additional specifications we will supply sprockets on the basis of DIN 6885 sheet 1



Standard sprockets

Standard sprockets can be supplied ex stock with custom bore or bored and grooved "ready-to-install" at extra cost.

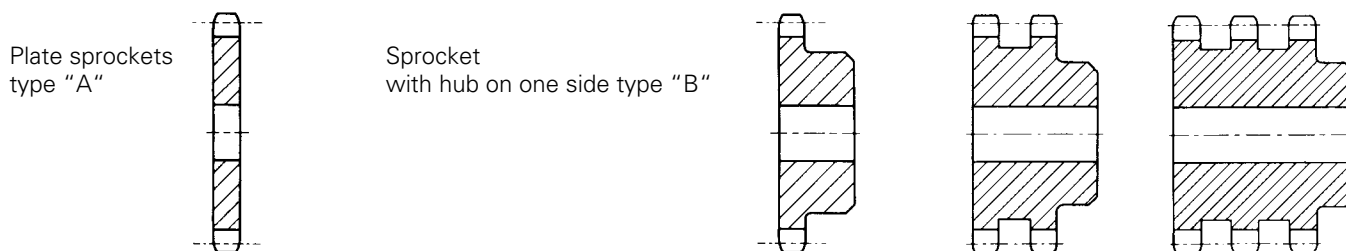

Sprockets made to specifications

Sprockets can be manufactured to your specifications and drawings.

Sprockets with hub on both sides (type "C") can be symmetrical or asymmetrical. For asymmetrical hub lengths the two hub sections l_1 and l_2 up to the centre of the sprocket must be stated in your order.

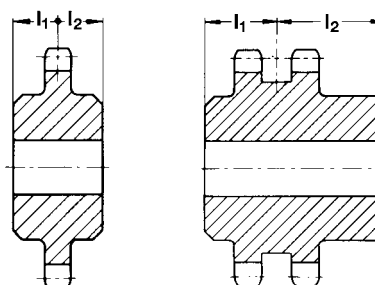

Material grades

For sprockets with a diameter of up to approx. 300 mm unalloyed steel with a steel strength of 500 - 600 N/mm² (S355JOC, C45 and the like) are usually sufficient. For larger sprockets cast iron suffices in case of normal loads.

For drive pinions subjected to high loads with speeds of more than 500 rpm or with chain speeds of more than 1 m/s it is recommended to harden or to harden and temper the teeth to 50 ± 2 HRC.

Groove sizes

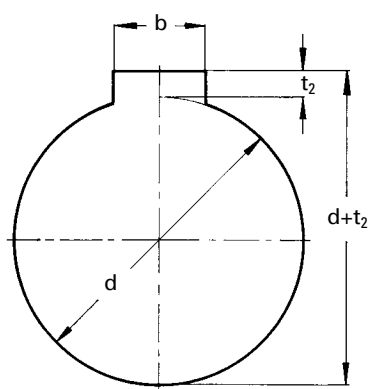

Groove sizes for woodruff keys DIN 6888 are in accordance with: DIN 6885 sheet 1 (with clearance) design A, DIN 6885 sheet 2 design B

We manufacture hub grooves only when specifically ordered by our customers. If no further specifications are given, we will work according to DIN 6885 sheet 1.

DIN	for shaft diameter	Groove width	Feather keys			Keyways		Hollow keys	Flat keys		
			6885	6885	6885	6886	6887	6881/6889	6883/6884		
			Sheet 1	Sheet 2	Sheet 3						
	d	b	Groove depth t_2								
			with clearance	with over-size		with clearance	with over-size				
more than	6 to 8	2,0	1,0	0,5	-	-	-	0,5	-	-	-
"	8 " 10	3,0	1,4	0,9	-	-	-	0,9	-	-	-
"	10 " 12	4,0	1,8	1,2	1,1	-	-	1,2	1,2	-	-
"	12 " 17	5,0	2,3	1,7	1,3	1,2	0,8	1,7	1,7	-	-
"	17 " 22	6,0	2,8	2,2	1,7	1,6	1,1	2,2	2,2	-	-
"	22 " 30	8,0	3,3	2,4	1,7	2,0	1,4	2,4	2,4	3,2	3,2
"	30 " 38	10,0	3,3	2,4	2,1	2,4	1,8	2,4	2,4	3,7	3,7
"	38 " 44	12,0	3,3	2,4	2,1	2,2	1,6	2,4	2,4	3,7	3,7
"	44 " 50	14,0	3,8	2,9	2,6	2,1	1,4	2,9	2,9	4,0	4,0
"	50 " 58	16,0	4,3	3,4	2,6	2,4	1,7	3,4	3,4	4,5	4,5
"	58 " 65	18,0	4,4	3,4	3,1	2,3	1,6	3,4	3,4	4,5	4,5
"	65 " 75	20,0	4,9	3,9	4,1	2,7	2,0	3,9	3,9	5,5	5,5
"	75 " 85	22,0	5,4	4,4	4,1	3,1	2,4	4,4	4,4	6,5	6,5
"	85 " 95	25,0	5,4	4,4	4,1	2,9	2,2	4,4	4,4	6,4	6,4
"	95 " 110	28,0	6,4	5,4	5,1	3,2	2,4	5,4	5,4	6,9	6,9
"	110 " 130	32,0	7,4	6,4	5,2	3,5	2,7	6,4	6,4	7,9	7,9
"	130 " 150	36,0	8,4	7,1	6,5	3,8	3,0	7,1	7,1	8,4	8,4
"	150 " 170	40,0	9,4	8,1	8,2	-	-	8,1	8,1	-	9,1
"	170 " 200	45,0	10,4	9,1	-	-	-	9,1	9,1	-	10,4
"	200 " 230	50,0	11,4	10,1	-	-	-	10,1	10,1	-	11,7
"	230 " 260	56,0	12,4	11,1	-	-	-	11,1	11,1	-	-

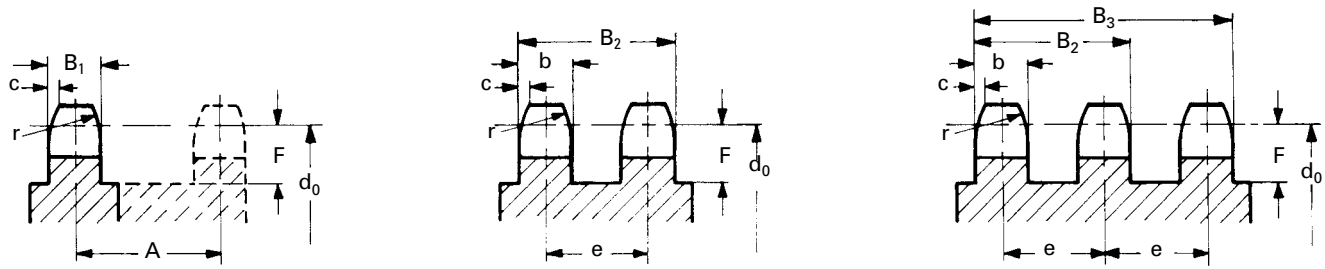

Simplex or 2 x simplex

Duplex

Triplex

- B_1 : Tooth width for simplex sprocket
- b : Tooth width for multiplex sprocket
- B_2 : Tooth width over duplex sprocket
- B_3 : Tooth width over triplex sprocket
- c : Chamfer of tooth width 0,1 to 0,15 p
- r : Tooth chamfer radius $\geq p$
- e : Transverse pitch
- F : Undercut
- A : Centre to centre distance for separated chain strands
(only for 2 x simplex roller chain, each with outer connecting side)

Roller chains according to ISO 606 (European type)

Chain	Chain dimensions			Profile dimensions							
	Pitch		Inner width	Roller \varnothing	e	B_1	b	B_2^*	B_3^*	F	A
	p		b_1	d_1		B_1	b	B_2^*	B_3^*	F	A
No.	mm	inch	mm	mm	mm	mm	mm	mm	mm	mm	mm
440	5,000	-	2,50	3,20	-	2,3	-	-	-	3,0	9
445, D 445	6,000	-	2,80	4,00	5,50	2,6	2,5	8,0	-	3,5	9
450, D 450, T 450	8,000	-	3,00	5,00	5,64	2,8	2,7	8,3	14,0	5,0	10
453	9,525	$\frac{3}{8}$	3,30	6,00	-	3,0	-	-	-	6,0	11
454	9,525	$\frac{3}{8}$	3,94	6,35	-	3,6	-	-	-	6,0	13
455, D 455, T 455	9,525	$\frac{3}{8}$	5,72	6,35	10,24	5,3	5,2	15,4	25,7	6,0	15
331	12,700	$\frac{1}{2}$	3,30	7,75	-	3,0	-	-	-	7,0	12
332, 17	12,700	$\frac{1}{2}$	4,88	7,75	-	4,5	-	-	-	7,0	15
110	12,700	$\frac{1}{2}$	2,38	7,75	-	2,2	-	-	-	7,0	9
41	12,700	$\frac{1}{2}$	6,38	7,75	-	5,9	-	-	-	7,0	16
385	12,700	$\frac{1}{2}$	6,40	7,75	-	5,9	-	-	-	8,0	18
461	12,700	$\frac{1}{2}$	6,40	8,51	-	5,9	-	-	-	8,0	18
462, D 462, T 462	12,700	$\frac{1}{2}$	7,75	8,51	13,92	7,2	7,0	21,0	34,8	8,0	20
500	15,875	$\frac{5}{8}$	6,48	10,16	-	6,1	-	-	-	10,0	19
501, D 501, T 501	15,875	$\frac{5}{8}$	9,65	10,16	16,59	9,1	9,0	25,6	42,2	10,0	23
513, D 513, T 513	19,050	$\frac{3}{4}$	11,68	12,07	19,46	11,1	10,8	30,3	49,7	11,0	27
548, D 548, T 548	25,400	1	17,02	15,88	31,88	16,2	15,8	47,7	79,6	15,0	42
552	30,000	-	17,02	15,88	-	16,2	-	-	-	15,0	42
563, D 563, T 563	31,750	1 $\frac{1}{4}$	19,56	19,05	36,45	18,5	18,2	54,6	91,1	18,0	50
596, D 596, T 596	38,100	1 $\frac{1}{2}$	25,40	25,40	48,36	24,1	23,6	72,0	120,3	23,0	63
613, D 613, T 613	44,450	1 $\frac{3}{4}$	30,99	27,94	59,56	29,4	28,8	88,4	147,9	25,0	76
652, D 652, T 652	50,800	2	30,99	29,21	58,55	29,4	28,8	87,4	145,9	29,0	79
671, D 671, T 671	63,500	2 $\frac{1}{2}$	38,10	39,37	72,29	36,2	35,4	107,7	180,0	36,0	97
679, D 679, T 679	76,200	3	45,72	48,26	91,21	43,4	42,5	133,7	224,9	43,0	116

Roller chains according to ISO 606 (American type)

35, 35-2, 35-3	9,525	$\frac{3}{8}$	4,77	5,08	10,13	4,4	4,3	14,4	24,5	6,0	15
40, 40-2, 40-3	12,700	$\frac{1}{2}$	7,85	7,95	14,38	7,4	7,2	21,6	36,0	8,0	20
50, 50-2, 50-3	15,875	$\frac{5}{8}$	9,40	10,16	18,11	9,0	8,8	26,9	45,0	10,0	25
60, 60 H, 60-2, 60-3	19,050	$\frac{3}{4}$	12,57	11,91	22,78	12,0	11,8	34,6	57,3	12,0	31/33**
80, 80 H, 80-2, 80-3	25,400	1	15,75	15,88	29,29	15,1	14,8	44,1	73,4	16,0	39/42**
100, 100 H, 100-2, 100-3	31,750	1 $\frac{1}{4}$	18,90	19,05	35,76	18,1	17,7	53,4	89,2	20,0	48/51**
120, 120-2, 120-3	38,100	1 $\frac{1}{2}$	25,22	22,23	45,44	24,1	23,6	69,0	114,5	24,0	60
140, 140-2, 140-3	44,450	1 $\frac{3}{4}$	25,22	25,40	48,87	24,1	23,6	72,5	121,3	28,0	64
160, 160-2, 160-3	50,800	2	31,55	28,58	58,55	30,1	29,5	88,0	146,6	32,0	77
200, 200-2, 200-3	63,500	2 $\frac{1}{2}$	37,85	39,68	71,55	36,2	35,4	106,9	178,5	40,0	94

* rounded off values ** the second value only applies to chains of type series "H"

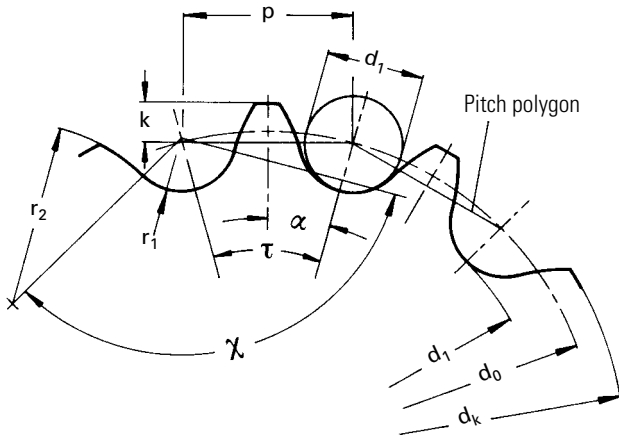

- p : Pitch
- z : Number of teeth
- d₁ : Roller diameter, bushing diameter or pin diameter
- d₀ : PCD
- d_k : Tip circle diameter
- d_f : Root circle diameter
- t : Pitch angle = $\frac{360^\circ}{z}$ $\alpha = \frac{180^\circ}{z}$
- x : Roller contact angle
- k : Tooth height above pitch polygon
(Diameter of pitch polygon = p cot α)
- r₁ : Tooth root radius
- r₂ : Tooth profile radius
- n : Factor for the number of teeth = $\frac{1}{\sin \alpha} = \frac{1}{\sin (180^\circ/z)}$

PCD

$$d_0 = \frac{p}{\sin \alpha} = \frac{p}{\sin (180^\circ/z)} = pn$$

Tip circle diameter d_k

a) Roller chain sprockets

$$d_k = p \cot \alpha + 0,8 d_1 = d_0 \cos \alpha + 0,8 d_1$$

the following applies with sufficient accuracy:

$$\begin{aligned} d_k &= d_0 + 0,5 \dots 0,6 d_1 & z &= 6 \dots \dots \dots 12 \text{ teeth} \\ d_k &= d_0 + 0,6 \dots 0,7 d_1 & z &= 13 \dots \dots \dots 25 \text{ teeth} \\ d_k &= d_0 + 0,7 \dots 0,8 d_1 & z &= \text{more than 25 teeth} \end{aligned}$$

b) Bush chain sprockets

$$d_k = d_0 + 0,8 \dots 1,0 d_1$$

c) Galle chain sprockets

$$d_k = d_0 + d_1$$

Root circle diameter

$$d_f = d_0 - d_1$$

Toothing check

a) by measuring

In order to check the sprocket toothing the root circle diameter must be determined by means of measuring pins with the same diameters as the chain rollers,

but with the tolerance $\begin{matrix} + 0,01 \\ 0,00 \end{matrix}$

For an even number of teeth the measure M is:

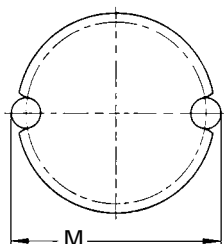

$$M = d_0 + d_1$$

$$M = pn + d_1$$

For an uneven number of teeth the measure M is: over 2 measuring pins over 3 measuring pins

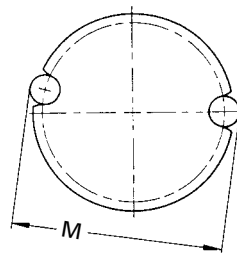

$$M = d_0 \cos \frac{\alpha}{2} + d_1$$

$$M = pn \cos \frac{\alpha}{2} + d_1$$

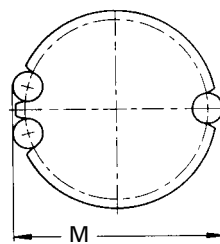

$$M = \frac{p}{2} \left(\frac{1}{\sin \alpha} + \cot \alpha \right) + d_1$$

$$M = \frac{p}{2} (n + \cot \alpha) + d_1$$

b) by means of a chain looped around the sprocket

It must be possible to fully loop the chain around the sprocket quite easily. If the toothing was milled too deeply, the sprocket is defective and must be scrapped! In case of the root circle diameter being too long (i.e. the chain cannot be looped around the sprocket and moves upwards on the tooth flanks after a few links), the sprocket can be milled again.

Toothing check by means of a chain looped around the sprocket

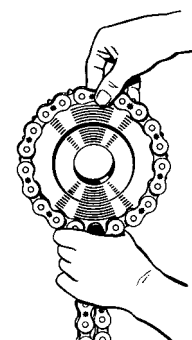

For permissible deviations of the measure M the tolerances of the root circle diameter (h₁₁) apply.



Chain No. 	440		445 D 450		450 D 450 T 450		35 35-2 35-3		453, 454 455 D 455 T 455		17, 18, 41 110, 331 40 40-2 40-3	
Pitch p	5,0		6,0		8,0		9,525		9,525		12,7	
Roller $\varnothing d_1$	3,2		4,0		5,0		5,08		6,0 - 6,35		7,75 - 7,95	
Number of teeth z	PCD	Tip circle \varnothing	PCD	Tip circle \varnothing	PCD	Tip circle \varnothing	PCD	Tip circle \varnothing	PCD	Tip circle \varnothing	PCD	Tip circle \varnothing
	d_0	d_k	d_0	d_k	d_0	d_k	d_0	d_k	d_0	d_k	d_0	d_k
11	17,75	19,6	21,30	23,6	28,40	31,2	33,81	36,5	33,81	37,5	45,08	49,6
12	19,32	21,2	23,18	25,6	30,91	33,8	36,80	39,6	36,80	40,6	49,07	53,8
13	20,89	22,8	25,07	27,5	33,43	36,4	39,80	42,7	39,80	43,7	53,07	57,9
14	22,47	24,5	26,96	29,5	35,95	39,0	42,81	45,8	42,81	46,8	57,07	62,0
15	24,05	26,1	28,86	31,4	38,48	41,6	45,81	48,9	45,81	49,9	61,08	66,1
16	25,63	27,7	30,75	33,3	41,01	44,2	48,82	52,0	48,82	53,0	65,10	70,2
17	27,21	29,3	32,65	35,2	43,54	46,8	51,84	55,0	51,84	56,0	69,12	74,3
18	28,79	30,9	34,55	37,2	46,07	49,5	54,85	58,1	54,85	59,1	73,14	78,4
19	30,38	32,5	36,45	39,1	48,60	51,9	57,87	61,2	57,87	62,2	77,16	82,5
20	31,96	34,2	38,36	41,1	51,14	54,5	60,89	64,2	60,89	65,2	81,18	86,6
21	33,55	35,7	40,26	43,0	53,68	57,1	63,91	67,3	63,91	68,3	85,21	90,6
22	35,13	37,3	42,16	44,9	56,21	59,6	66,93	70,3	66,93	71,3	89,24	94,7
23	36,72	38,9	44,06	46,8	58,75	62,2	69,95	73,4	69,95	74,4	93,27	98,8
24	38,31	40,5	45,97	48,8	61,29	64,8	72,97	76,4	72,97	77,4	97,30	102,9
25	39,89	42,2	47,87	50,7	63,83	67,3	76,00	79,5	76,00	80,5	101,33	106,9
26	41,48	43,7	49,78	52,6	66,37	69,9	79,02	82,5	79,02	83,5	105,36	111,0
27	43,07	45,3	51,68	54,5	68,91	72,4	82,05	85,6	82,05	86,6	109,40	115,0
28	44,66	46,9	53,59	56,4	71,45	75,0	85,07	88,6	85,07	89,6	113,43	119,1
29	46,25	48,5	55,49	58,4	73,99	77,5	88,10	91,7	88,10	92,7	117,46	123,2
30	47,83	50,1	57,40	60,3	76,53	80,1	91,12	94,7	91,12	95,7	121,50	127,2
31	49,42	51,7	59,31	62,2	79,08	82,7	94,15	97,8	94,15	98,8	125,53	131,3
32	51,01	53,3	61,21	64,1	81,62	85,7	97,18	100,8	97,18	101,8	129,57	135,3
33	52,60	54,9	63,12	66,0	84,16	87,8	100,20	103,8	100,20	104,8	133,61	139,4
34	54,19	56,5	65,03	67,9	86,70	90,3	103,23	106,9	103,23	107,9	137,64	143,4
35	55,78	58,2	66,93	69,8	89,25	92,9	106,26	109,9	106,26	110,9	141,68	147,5
36	57,37	59,7	68,84	71,8	91,79	95,4	109,29	113,0	109,29	114,0	145,72	151,5
37	58,96	61,3	70,75	73,7	94,33	98,0	112,31	116,0	112,31	117,0	149,75	155,6
38	60,55	62,9	72,66	75,6	96,88	100,5	115,34	119,0	115,34	120,0	153,79	159,6
39	62,14	64,5	74,57	77,5	99,42	103,1	118,37	122,1	118,37	123,1	157,83	163,7
40	63,73	66,1	76,47	79,4	101,96	105,6	121,40	125,1	121,40	126,1	161,87	167,7
41	65,32	67,7	78,38	81,3	104,51	108,2	124,43	128,1	124,43	129,1	165,91	171,8
42	66,91	69,3	80,29	83,2	107,05	110,7	127,46	131,2	127,46	132,2	169,95	175,9
43	68,50	70,9	82,20	85,2	109,60	113,3	130,49	134,2	130,49	135,2	173,98	179,9
44	70,09	72,5	84,11	87,1	112,14	115,8	133,52	137,2	133,52	138,2	178,02	184,0
45	71,68	74,1	86,01	89,0	114,68	118,4	136,55	140,3	136,55	141,3	182,06	188,0
46	73,27	75,7	87,92	90,9	117,23	120,9	139,58	143,3	139,58	144,3	186,10	192,0
47	74,86	77,3	89,83	92,8	119,77	123,5	142,61	146,4	142,61	147,4	190,14	196,1
48	76,45	78,8	91,74	94,7	122,32	126,0	145,64	149,4	145,64	150,4	194,18	200,1
49	78,04	80,4	93,65	96,6	124,86	128,6	148,67	152,4	148,67	153,4	198,22	204,2
50	79,63	82,0	95,56	98,5	127,41	131,1	151,70	155,5	151,70	156,5	202,26	208,2
51	81,22	83,6	97,46	100,5	129,95	133,7	154,73	158,5	154,73	159,5	206,30	212,3
52	82,81	85,2	99,37	102,4	132,50	136,2	157,75	161,5	157,75	162,5	210,34	216,3
53	84,40	86,8	101,28	104,3	135,04	138,8	160,78	164,5	160,78	165,6	214,38	220,4
54	85,99	88,4	103,19	106,2	137,59	141,3	163,81	167,6	163,81	168,6	218,42	224,4
55	87,58	90,0	105,10	108,1	140,13	143,9	166,85	170,6	166,85	171,6	222,46	228,5
56	89,17	91,6	107,01	110,0	142,68	146,4	169,88	173,7	169,88	174,7	226,50	232,5
57	90,76	93,2	108,92	111,9	145,22	149,0	172,91	176,7	172,91	177,7	230,54	236,6
58	92,36	94,8	110,83	113,8	147,77	151,5	175,94	179,8	175,94	180,8	234,58	240,6
59	93,95	96,4	112,74	115,8	150,31	154,1	178,97	182,8	178,97	183,8	238,62	244,7
60	95,54	98,0	114,64	117,7	152,86	156,7	182,00	185,8	182,00	186,8	242,66	248,7
61	97,13	99,6	116,55	119,6	155,40	159,2	185,03	188,9	185,03	189,9	246,70	252,8
62	98,72	101,2	118,46	121,5	157,95	161,7	188,06	191,9	188,06	192,9	250,74	256,8
63	100,31	102,7	120,37	123,4	160,50	164,3	191,09	194,9	191,09	195,9	254,79	260,9
64	101,90	104,3	122,28	125,3	163,04	166,8	194,12	198,0	194,12	199,0	258,83	264,9
65	103,49	105,9	124,19	127,2	165,59	169,4	197,15	201,0	197,15	202,0	262,87	268,9
66	105,08	107,5	126,10	129,1	168,13	171,9	200,18	204,0	200,18	205,0	266,91	273,0
67	106,67	109,1	128,01	131,0	170,68	174,5	203,21	207,1	203,21	208,1	270,95	277,0
68	108,26	110,7	129,92	132,9	173,22	177,0	206,24	210,1	206,24	211,1	274,99	281,1
69	109,86	112,3	131,83	134,9	175,77	179,6	209,27	213,1	209,27	214,1	279,03	285,1
70	111,45	113,9	133,74	136,8	178,31	182,1	212,30	216,2	212,30	217,2	283,07	289,2

All dimensions in mm



Chain No. 	460 461 462 D 462 T 462		50 H 50 HX 50 50-2 50-3		500 501 D 501 F 501		60 60-2 60-3 60 H 60 HX		513 D 513 T 513 515 517		80 H 80 HX 80 80-2 80-3		548 D 548 T 548		100 HX 100 100-2 100-3		563 D 563 T 563		120 HX 120 120-2 120-3	
	Pitch p	12,7		15,875		19,05		25,4		31,75		38,1								
Roller $\varnothing d_1$	8,51		10,16		11,91 - 12,07		15,88		19,05		22,23									
Number of teeth z	D 462	Tip circle \varnothing	PCD	Tip circle \varnothing	PCD	Tip circle \varnothing	PCD	Tip circle \varnothing	PCD	Tip circle \varnothing	PCD	Tip circle \varnothing	PCD	Tip circle \varnothing	PCD	Tip circle \varnothing	PCD	Tip circle \varnothing	PCD	Tip circle \varnothing
	T 462	50 H	d_0	d_k	d_0	d_k	d_0	d_k	d_0	d_k	d_0	d_k	d_0	d_k	d_0	d_k	d_0	d_k	d_0	d_k
11	45,08	50,0	56,35	62,2	67,62	74,5	90,16	99,2	112,69	123,4	135,23	147,6								
12	49,07	54,2	61,34	67,4	73,60	80,7	98,14	107,5	122,67	133,7	147,21	160,0								
13	53,07	58,3	66,34	72,5	79,60	86,9	106,14	115,7	132,67	144,0	159,21	172,4								
14	57,07	62,4	71,34	77,7	85,61	93,1	114,15	124,0	142,68	154,3	171,22	184,7								
15	61,08	66,5	76,35	82,8	91,62	99,2	122,17	132,2	152,71	164,6	183,25	197,0								
16	65,10	70,6	81,37	87,9	97,65	105,4	130,20	140,4	162,74	174,9	195,29	209,3								
17	69,12	74,7	86,39	93,0	103,67	111,5	138,23	148,5	172,79	185,1	207,35	221,6								
18	73,14	78,8	91,42	98,1	109,71	117,7	146,27	156,7	182,84	195,3	219,41	233,9								
19	77,16	82,9	96,45	103,2	115,74	123,8	154,32	164,9	192,90	205,5	231,48	246,1								
20	81,18	87,0	101,48	108,3	121,78	129,9	162,37	173,0	202,96	215,7	243,55	258,4								
21	85,21	91,0	106,51	113,4	127,82	136,0	170,42	181,2	213,03	225,9	255,63	270,6								
22	89,24	95,1	111,55	118,5	133,86	142,1	178,48	189,3	223,10	236,1	267,72	282,8								
23	93,27	99,2	116,59	123,6	139,90	148,2	186,54	197,5	233,17	246,2	279,81	295,0								
24	97,30	103,3	121,62	128,7	145,95	154,3	194,60	205,6	243,25	256,4	291,90	307,2								
25	101,33	107,3	126,66	133,8	151,99	160,4	202,66	213,7	253,32	266,6	303,99	319,4								
26	105,36	111,4	131,70	138,8	158,04	166,5	210,72	221,9	263,40	276,7	316,09	331,6								
27	109,40	115,4	136,74	143,9	164,09	172,6	218,79	230,0	273,49	286,9	328,19	343,8								
28	113,43	119,5	141,79	149,0	170,14	178,7	226,86	238,1	283,57	297,0	340,29	355,9								
29	117,46	123,6	146,83	154,1	176,20	184,8	234,93	246,2	293,66	307,2	352,39	368,1								
30	121,50	127,6	151,87	159,1	182,25	190,9	243,00	254,3	303,75	317,3	364,50	380,3								
31	125,53	131,7	156,92	164,2	188,30	197,0	251,07	262,5	313,83	327,5	376,60	392,5								
32	129,57	135,7	161,96	169,3	194,35	203,0	259,14	270,6	323,92	337,6	388,71	404,6								
33	133,61	139,8	167,01	174,4	200,41	209,1	267,21	278,7	334,01	347,7	400,82	416,8								
34	137,64	143,8	172,05	179,4	206,46	215,2	275,29	286,8	344,11	357,9	412,93	428,9								
35	141,68	147,9	177,10	184,5	212,52	221,3	283,36	294,9	354,20	368,0	425,04	441,1								
36	145,72	152,0	182,14	189,6	218,57	227,4	291,43	303,0	364,29	378,1	437,15	453,3								
37	149,75	156,0	187,19	194,6	224,63	233,5	299,51	311,1	374,38	388,3	449,26	465,4								
38	153,79	160,1	192,24	199,7	230,69	239,5	307,58	319,2	384,48	398,4	461,38	477,6								
39	157,83	164,1	197,29	204,8	236,74	245,6	315,66	327,3	394,57	408,5	473,49	489,8								
40	161,87	168,2	202,35	209,8	242,80	251,7	323,74	335,4	404,67	418,7	485,60	501,9								
41	165,91	172,2	207,38	214,9	248,86	257,8	331,81	343,5	414,77	428,8	497,72	514,1								
42	169,95	176,3	212,43	219,9	254,92	263,8	339,89	351,6	424,86	438,9	509,84	526,2								
43	173,98	180,3	217,48	225,0	260,98	269,9	347,97	359,7	434,96	449,0	521,95	538,4								
44	178,02	184,4	222,53	230,1	267,04	276,0	356,05	367,8	445,06	459,2	534,07	551,5								
45	182,06	188,4	227,58	235,1	273,09	282,0	364,12	375,9	455,16	469,3	546,19	562,6								
46	186,10	192,5	232,63	240,2	279,15	288,1	372,20	384,0	465,25	479,4	558,31	574,8								
47	190,14	196,5	237,68	245,3	285,21	294,2	380,28	392,1	475,35	489,5	570,42	586,9								
48	194,18	200,6	242,73	250,3	291,27	300,3	388,36	400,2	485,45	499,6	582,54	599,1								
49	198,22	204,6	247,78	255,4	297,33	306,4	396,44	408,3	495,55	509,8	594,66	611,2								
50	202,26	208,6	252,83	260,4	303,39	312,4	404,52	416,4	505,65	519,9	606,78	623,4								
51	206,30	212,7	257,88	265,5	309,45	318,5	412,60	424,5	515,75	530,0	618,90	635,5								
52	210,34	216,7	262,93	270,6	315,51	324,6	420,68	432,6	525,85	540,1	631,02	647,8								
53	214,38	220,8	267,97	275,6	321,57	330,6	428,76	440,7	535,95	550,2	643,14	659,8								
54	218,42	224,8	273,02	280,7	327,63	336,7	436,84	448,8	546,05	560,4	655,26	671,9								
55	222,46	228,9	278,08	285,7	333,69	342,8	444,92	456,9	556,15	570,5	667,38	684,1								
56	226,50	232,9	283,13	290,8	339,75	348,8	453,00	465,0	566,25	580,6	679,50	696,2								
57	230,54	237,0	288,18	295,8	345,81	354,9	461,08	473,1	576,35	590,7	691,63	708,4								
58	234,58	241,0	293,23	300,9	351,87	361,0	469,16	481,2	586,45	600,8	703,75	720,5								
59	238,62	245,1	298,28	306,0	357,93	367,0	477,24	489,2	596,56	610,9	715,87	732,6								
60	242,66	249,1	303,33	311,0	363,99	373,1	485,33	497,3	606,66	621,0	727,99	744,8								
61	246,70	253,2	308,38	316,1	370,06	379,2	493,41	505,4	616,76	631,1	740,11	756,9								
62	250,74	257,2	313,43	321,1	376,12	385,3	501,49	513,5	626,86	641,3	752,23	769,1								
63	254,79	261,3	318,48	326,2	382,18	391,3	509,57	521,6	636,97	651,4	764,36	781,2								
64	258,83	265,3	323,53	331,2	388,24	397,4	517,65	529,7	647,07	661,5	776,48	793,3								
65	262,87	269,4	328,58	336,3	394,30	403,5	525,73	537,8	657,17	671,6	788,60	805,5								
66	266,91	273,4	333,64	341,4	400,36	409,5	533,82	545,9	667,27	681,7	800,72	817,6								
67	270,95	277,4	338,69	346,4	406,42	415,6	541,90	554,0	677,37	691,9	812,85	829,8								
68	274,99	281,5	343,74	351,5	412,49	421,7	549,98	562,1	687,48	701,9	824,97	841,9								
69	279,03	285,5	348,79	356,5	418,55	427,7	558,06	570,2	697,58	712,0	837,10	854,0								
70	283,07	289,6	353,84	361,6	424,61	433,8	566,15	578,2	707,68	722,2	849,22	866,1								

All dimensions in mm



Chain No. 	596 R 596 SX 596 D 596 T 596		140 HX 140 140-2 140-3		613 D 613 T 613		160 HX 160 160-2 160-3		652 D 652 T 652		200 HX 200 200-2 200-3		671 SX D 671 T 671		679 D 679 T 679	
	Pitch p	38,1	44,45		44,45		50,8		63,5		76,2					
Roller $\varnothing d_1$	25,4		25,4		27,94		28,58 - 29,21		39,37 - 39,68		48,26					
Number of teeth z	D 462	Tip circle \varnothing	PCD	Tip circle \varnothing	PCD	Tip circle \varnothing	PCD	Tip circle \varnothing	PCD	Tip circle \varnothing	PCD	Tip circle \varnothing	PCD	Tip circle \varnothing		
	T 462	50 H	d_0	d_k	d_0	d_k	d_0	d_k	d_0	d_k	d_0	d_k	d_0	d_k		
11	135,23	150,0	157,77	171,8	157,77	173,8	180,31	196,4	225,39	248,1	270,47	298,1				
12	147,21	162,5	171,74	186,3	171,74	188,3	196,28	213,0	245,35	268,8	294,41	323,0				
13	159,21	174,9	185,74	200,7	185,74	202,7	212,27	229,5	265,34	289,4	318,41	347,7				
14	171,22	187,2	199,76	215,1	199,76	217,1	228,30	246,0	285,37	310,0	342,44	372,5				
15	183,25	199,5	213,79	229,5	213,79	231,5	244,33	262,4	305,42	330,5	366,50	397,1				
16	195,29	211,8	227,84	243,9	227,84	245,9	260,39	278,8	325,49	351,0	390,59	421,7				
17	207,35	224,1	241,91	258,2	241,91	260,2	276,46	295,2	345,58	371,5	414,70	446,2				
18	219,41	236,3	255,98	272,5	255,98	274,5	292,55	311,5	365,68	391,9	438,82	470,7				
19	231,48	248,6	270,06	286,8	270,06	288,8	308,64	327,8	385,79	412,3	462,95	495,2				
20	243,55	260,9	284,15	301,0	284,15	303,0	324,74	344,1	405,92	432,7	487,11	519,7				
21	255,63	273,1	298,24	315,3	298,24	317,3	340,84	360,4	426,05	453,1	511,26	544,2				
22	267,72	285,3	312,34	329,6	312,34	331,6	356,96	376,7	446,20	473,5	535,44	568,6				
23	279,81	297,5	326,44	343,8	326,44	345,8	373,07	393,0	466,34	493,8	559,61	593,0				
24	291,90	309,7	340,55	358,0	340,55	360,0	389,19	409,3	486,49	514,1	583,79	617,4				
25	303,99	321,9	354,65	372,3	354,65	374,3	405,32	425,5	506,65	534,5	607,98	641,8				
26	316,09	334,1	368,77	386,5	368,77	388,5	421,45	441,8	526,81	554,8	632,17	666,2				
27	328,19	346,2	382,88	400,7	382,88	402,7	437,58	458,0	546,98	575,1	656,37	690,5				
28	340,29	358,4	397,00	414,9	397,00	416,9	453,72	474,3	567,14	595,4	680,57	714,9				
29	352,39	370,6	411,12	429,1	411,12	431,1	469,85	490,5	587,32	615,7	704,78	739,2				
30	364,50	382,8	425,24	443,3	425,24	445,3	485,99	506,7	607,49	636,0	728,99	763,6				
31	376,60	395,0	439,37	457,5	439,37	459,5	502,13	523,0	627,67	656,2	753,20	787,9				
32	388,71	407,1	453,49	471,7	453,49	473,7	518,28	539,2	647,85	676,5	777,42	812,3				
33	400,82	419,3	467,62	485,8	467,62	487,9	534,42	555,4	668,03	696,8	801,63	836,6				
34	412,93	431,4	481,75	500,1	481,75	502,1	550,57	571,6	688,21	717,1	825,86	860,9				
35	425,04	443,6	495,88	514,3	495,88	516,3	566,72	587,8	708,39	737,3	850,07	885,3				
36	437,15	455,8	510,01	528,5	510,01	530,5	582,86	604,0	728,58	757,6	874,30	909,6				
37	449,26	467,9	524,14	542,7	524,14	544,7	599,01	620,3	748,77	777,9	898,52	933,9				
38	461,38	480,1	538,27	556,8	538,27	558,8	615,17	636,5	768,96	798,1	922,75	958,2				
39	473,49	492,2	552,40	571,0	552,40	573,0	631,32	652,7	789,15	818,4	946,98	982,5				
40	485,60	504,4	566,54	585,2	566,54	587,2	647,47	668,9	809,34	838,6	971,21	1007,0				
41	497,72	516,6	580,67	599,4	580,67	601,4	663,63	685,1	829,53	858,9	995,44	1031,0				
42	509,84	528,7	594,81	613,5	594,81	615,5	679,78	701,3	849,73	879,2	1019,67	1055,0				
43	521,95	540,9	608,94	627,7	608,94	629,7	695,93	717,5	869,92	899,4	1043,90	1080,0				
44	534,07	553,0	623,08	641,9	623,08	643,9	712,09	733,7	890,12	919,6	1068,14	1104,0				
45	546,19	565,1	637,22	656,1	637,22	658,1	728,25	749,9	910,31	939,9	1092,37	1128,0				
46	558,31	577,3	651,36	670,2	651,36	672,2	744,41	766,1	930,51	960,1	1116,61	1153,0				
47	570,42	589,4	665,49	684,4	665,49	686,4	760,56	782,3	950,70	980,4	1140,84	1177,0				
48	582,54	601,6	679,63	698,6	679,63	700,6	776,72	798,5	970,90	1000,0	1165,08	1201,0				
49	594,66	613,7	693,77	712,7	693,77	714,7	792,88	814,7	991,10	1021,0	1189,32	1226,0				
50	606,78	625,9	707,91	726,9	707,91	728,9	809,04	830,8	1011,30	1041,0	1213,56	1250,0				
51	618,90	638,0	722,05	741,1	722,05	743,1	825,20	847,0	1031,50	1061,0	1237,80	1274,0				
52	631,02	650,2	736,19	755,2	736,19	757,2	841,36	863,2	1051,70	1082,0	1262,04	1298,0				
53	643,14	662,3	750,33	769,4	750,33	771,4	857,52	879,4	1071,90	1102,0	1286,28	1323,0				
54	655,26	674,4	764,47	783,6	764,47	785,6	873,68	895,6	1092,10	1122,0	1310,52	1347,0				
55	667,38	686,6	778,61	797,7	778,61	799,7	889,84	911,8	1112,30	1142,0	1334,76	1371,0				
56	679,50	698,7	792,75	811,9	792,75	813,9	906,00	928,0	1132,50	1163,0	1359,00	1395,0				
57	691,63	710,9	806,90	826,1	806,90	828,1	922,17	944,2	1152,71	1183,0	1383,25	1420,0				
58	703,75	723,0	821,04	840,2	821,04	842,2	938,33	960,4	1172,91	1203,0	1407,49	1444,0				
59	715,87	735,1	835,18	854,4	835,18	856,4	954,49	976,5	1193,11	1223,0	1431,74	1468,0				
60	727,99	747,3	849,32	868,5	849,32	870,5	970,65	992,7	1213,31	1243,0	1455,98	1493,0				
61	740,11	759,4	863,46	882,7	863,46	884,7	986,82	1009,0	1233,52	1264,0	1480,22	1517,0				
62	752,23	771,6	877,61	896,9	877,61	898,9	1002,97	1025,0	1253,72	1284,0	1504,46	1541,0				
63	764,36	783,7	891,75	911,0	891,75	913,0	1019,14	1041,0	1273,93	1304,0	1528,72	1565,0				
64	776,48	795,8	905,89	925,2	905,89	927,2	1035,30	1057,0	1294,13	1324,0	1552,96	1590,0				
65	788,60	808,0	920,03	939,4	920,03	941,4	1051,47	1074,0	1314,34	1345,0	1577,20	1614,0				
66	800,72	820,1	934,18	953,5	934,18	955,5	1067,63	1090,0	1334,54	1365,0	1601,45	1638,0				
67	812,85	832,3	948,32	967,7	948,32	969,7	1083,80	1106,0	1354,75	1385,0	1625,70	1663,0				
68	824,97	844,4	962,47	981,8	962,47	983,8	1099,96	1122,0	1374,95	1405,0	1649,94	1687,0				
69	837,10	856,5	976,61	996,0	976,61	998,0	1116,13	1138,0	1395,16	1425,0	1674,19	1711,0				
70	849,22	868,6	990,75	1010,0	990,75	1012,0	1132,29	1155,0	1415,36	1445,0	1698,44	1735,0				

All dimensions in mm

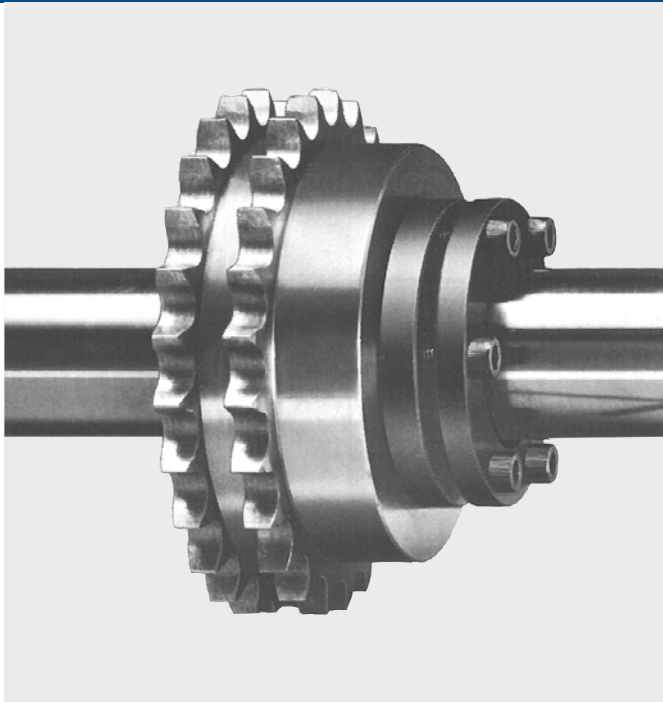

ETP shaft bushings

Friction-locked connection of sprockets and shafts

The ETP shaft bushing is a high-quality clamping element, which mounts components such as sprockets, toothed wheels, levers and other machine parts fast, easily and permanently onto shafts. Grooves, tapers and inside threads are no longer necessary.

Simply slide bushing and hub onto the shaft and tighten the few clamping screws. The only required tool is a simple hexagon wrench. However, a small torque wrench (up to 32 Nm) would be absolutely perfect. The transmissible torques easily exceed the allowable values of the shaft torsional stresses.

Here is an example for a shaft diameter of 40 mm with a feather key connection:

- a) Shaft material St 60: M_d approx. 230 Nm
- b) Shaft material 42 CrMo 4: M_d approx. 310 Nm

The ETP bushing transmits 800 Nm (at 20° Centigrade). Since it is not necessary to mill grooves into the shaft, the shaft diameter can be reduced by max. 25 % (2 x groove depth), i.e. a shaft with a diameter of 30 mm fitted with the proper bushing transmits at least 340 Nm.

This means more efficiency due to:

1. Material savings
2. Lower dimensioning of other components, particularly bearings.

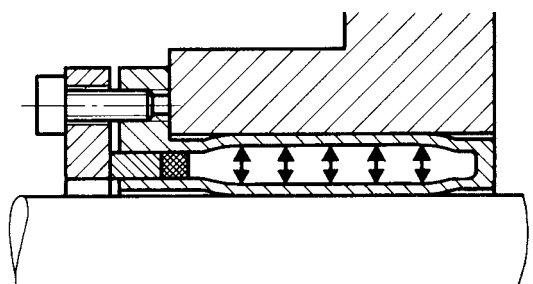

Bushing after tightening of clamping screws

Fine adjustments are possible. Adjusting the transmission elements is never a problem. The bushings are subsequently radially and axially adjustable to change positions without difficulty and backlash-free.

The ETP bushing is easy to repair. There will be no frictional corrosion since micro-movements are prevented due to the solid connection. The bushing can always be re-used, e.g. it can easily be mounted to a new sprocket. Subsequent machining on the old shaft will not be necessary.

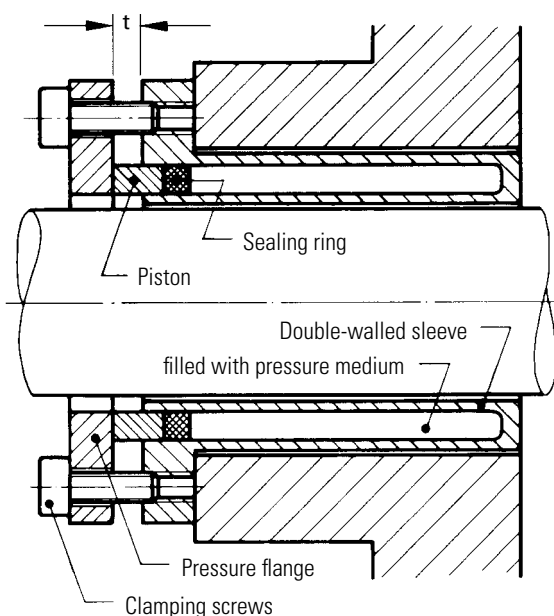

The ETP bushing consists of five parts: double-walled sleeve filled with pressure medium, sealing ring, piston, pressure flange and clamping screws (3, 4, 6 or 8 screws).

When the screws are being tightened, the piston forces the pressure medium in the double-walled sleeve against the walls. After tightening the screws with the required clamping torque M_{anz} , almost the entire bushing lies against shaft and hub. Thus the shaft and the respective part it is to be connected to are friction-locked. The pressure medium is resistant to material fatigue, and the clamping force of the bushing will persist. A 100 mm ETP bushing will then be non-slip up to a static moment of at least 12500 Nm. The maximum working temperature is 85°C.

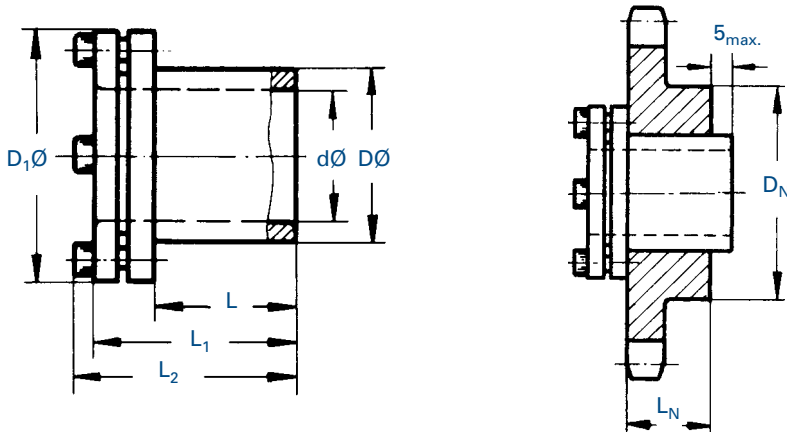

Order number	d	D	D ₁	L	L ₁	L ₂	M _N	F _N	Clamping screws			Weight	Hub Ø min.		Hub length L _N
									Number	Thread	M _{anz.}		Steel	Cast iron	
									at 20 °C						
							Nm	kN			Nm	kg	mm	mm	mm
ETP-15/23-17	15	23	36	17	28	32	43	5,7	3	M4	4,5	0,11	35	46	12
ETP-19/28-21	19	28	45	21	34	39	88	9,3	3	M5	7	0,18	42	56	16
ETP-20/28-22	20	28	45	22	40	45	125	13,0	3	M5	8	0,18	42	56	22
ETP-22/32-22	22	32	49	22	35	40	135	11,6	3	M5	8	0,21	48	64	17
ETP-24/34-25	24	34	49	25	38	43	175	14,4	4	M5	8	0,22	51	68	20
ETP-25/34-27	25	34	49	27	41	46	195	16,2	4	M5	8	0,22	51	68	22
ETP-28/39-29	28	39	55	29	43	48	280	19,5	4	M5	8	0,28	59	78	24
ETP-30/41-32	30	41	57	32	46	51	340	23,1	4	M5	8	0,30	62	82	27
ETP-32/43-34	32	43	60	34	50	55	410	26,1	4	M5	8	0,34	65	86	29
ETP-35/47-37	35	47	63	37	53	58	540	31,1	6	M5	8	0,40	71	94	32
ETP-38/50-41	38	50	65	41	57	62	700	37,4	6	M5	8	0,46	75	100	36
ETP-40/53-43	40	53	70	43	60	65	800	41,3	6	M5	8	0,58	80	106	38
ETP-42/55-45	42	55	70	45	62	67	940	45,4	6	M5	8	0,60	83	110	40
ETP-45/59-49	45	59	77	49	66	72	1180	53,0	6	M6	13	0,75	89	118	44
ETP-48/62-52	48	62	80	52	70	76	1370	59,9	6	M6	13	0,80	93	124	47
ETP-50/65-53	50	65	83	53	72	78	1620	64,8	6	M6	13	0,93	98	130	48
ETP-55/71-58	55	71	88	58	77	83	2110	77,9	8	M6	13	1,10	107	142	53
ETP-60/77-64	60	77	95	64	85	91	2750	93,6	8	M6	13	1,40	116	154	59
ETP-65/84-68	65	84	102	68	90	96	3430	108	8	M6	13	1,73	126	168	63
ETP-70/90-72	70	90	113	72	94	100	4300	124	6	M8	32	1,90	135	180	67
ETP-75/95-85	75	95	118	85	108	114	5300	153	6	M8	32	2,25	143	190	80
ETP-80/100-90	80	100	123	90	114	122	6400	173	6	M8	32	2,62	150	200	85
ETP-85/106-95	85	106	129	95	119	127	7700	194	6	M8	32	3,00	159	212	90
ETP-90/112-100	90	112	135	100	127	135	9100	216	8	M8	32	3,56	168	224	95
ETP-95/120-105	95	120	143	105	132	140	10700	239	8	M8	32	4,39	180	240	100
ETP-100/125-110	100	125	148	110	139	147	12500	264	8	M8	32	4,81	188	250	105

Dimensions, technical specifications and other details were correct at the time of printing, but are subject to change. M_{anz} is the clamping torque of the clamping screws to reach M_N or F_N. F_N is the transmissible axial force at a torque of 0. M_N is the transmissible torque at an axial force of 0.

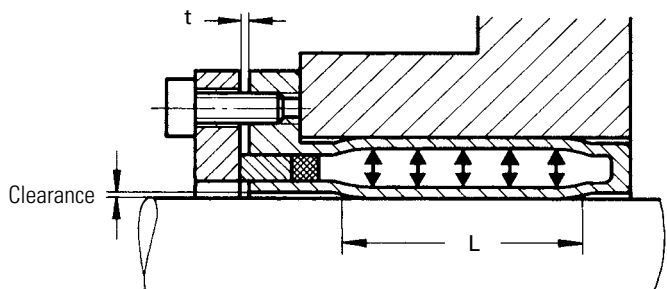

Fit tolerances

ETP bushings have been designed for the following fit tolerances:

Shafts $\text{Ø } h8 - k6$ (except 15 mm $\text{Ø} : h7$), hub bore hole H7. Permissible roughness depth: $R_a \text{ max.} = 3 / R_a \text{ min. } 1 [\mu\text{m}]$

Please note: the torque transmission (M) is influenced in a negative way, if the tolerance zone of the bushing connection does not comply with the recommended values. The distance (t) will diminish with increasing clearance. In case of exceedingly high tolerances the pressure flange will connect to the sleeve without the surface pressure required for the torque transmission being reached.

Hub dimensioning

Depending on the material used, the pressure reached at the maximum clamping torque requires a minimum wall thickness of the hub as well as a minimum hub length (see table).

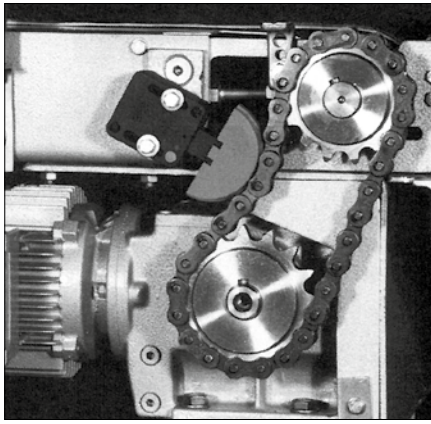

SPANN-BOX® size 0

SPANN-BOX® und SPANN-BOY®

Automatic chain drive tensioning

Not only correct lubrication and wheel alignment, but also chain re-tensioning to compensate for elongation is of crucial importance for a satisfactory life cycle of a chain drive.

Apart from chain tension wheels, our chain tensioners SPANN-BOY® and SPANN-BOX® offer perfect solutions. Due to different sizes and profiles they cover almost all application areas.

For controlling purposes SPANN-BOY® and SPANN-BOX® can be fitted with limit or proximity switches.

We can also supply SPANN-BOY® and SPANN-BOX® with casings or springs made of stainless steel.



SPANN-BOY®



SPANN-BOX® size 1
with deflecting profile



SPANN-BOX® size 1
with arch profile



SPANN-BOX® size 1 (type KL)
with sprocket



SPANN-BOX® size 1 (type KS)
with sprocket



SPANN-BOX® size 2
with block profile



Chain No.	Pitch mm	Arch profile				Semicircle profile				Deflecting profile				Block profile				Sprocket				
		Size				Size				Size				Size				Size				
		SPANN-BOY®				SPANN-BOY®				SPANN-BOY®				SPANN-BOY®				SPANN-BOY®				
		0	30	1	2	0	30	1	2	0	30	1	2	0	30	1	2	0	30	1	2	
not mentioned chains with width up to 15 mm						X	X															
455	9,525			X			X	X				X								X	X	
D 455	9,525	X	X			X	X					X										
T 455	9,525	X	X			X	X					X										
462	12,7	X	X			X	X					X								X	X	
D 462	12,7	X	X	X		X	X	X				X	X									
T 462	12,7	X	X	X				X	X			X	X									
501	15,875	X	X			X	X					X								X	X	
D 501	15,875	X	X	X		X		X	X			X	X									
T 501	15,875	X	X	X				X				X	X									
513	19,05	X	X	X		X		X	X			X	X							X	X	
D 513	19,05	X	X	X				X	X			X	X									
T 513	19,05		X	X								X										
548	25,4	X	X	X				X				X	X									
D 548	25,4		X	X																	X	
T 548	25,4			X																	X	
563	31,75		X	X								X										
D 563	31,75			X																	X	
T 563	31,75			X																	X	
596	38,1			X																	X	
D 596	38,1			X																	X	
T 596	38,1																				X	
613	44,45																				X	
D 613	44,45																				X	
T 613	44,45																				X	
652	50,8																				X	
D 652	50,8																				X	
T 652	50,8																				X	
671	63,5																				X	
D 671	63,5																				X	
T 671	63,5																				X	
679	76,2																				X	
D 679	76,2																				X	
T 679	76,2																				X	

Tension values and range of shift

Size	SPANN-BOY®		SPANN-BOX® size 0		SPANN-BOX® size 30 or 1		SPANN-BOX® size 2	
Range of shift	40 mm		40 mm		40 mm		60 mm	
Spring design	light	heavy	light	heavy	light	heavy	light	heavy
Tension force	N	N	N	N	N	N	N	N
1 spring released	58 - 32	132 - 60	58 - 32	132 - 60	58 - 32	132 - 60	148 - 82	262 - 116
2 springs released	-	-	-	-	116 - 64	264 - 120	296 - 164	524 - 236
3 springs released	-	-	-	-	174 - 96	396 - 180	444 - 246	786 - 454

The chain weight should not be higher than the force of a spring already released by 50%.
The second and the third spring may be activated later if required.

Further combinations and profiles made to specification are also available.



SPANN-BOX® size 0

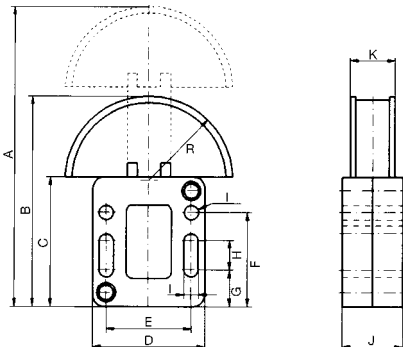

SPANN-BOX® size 30 with arch profile

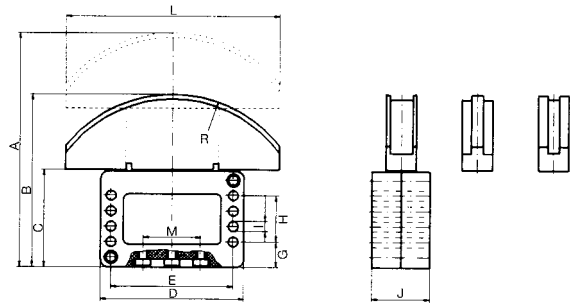

SPANN-BOX® size 1 and 2 with arch profile

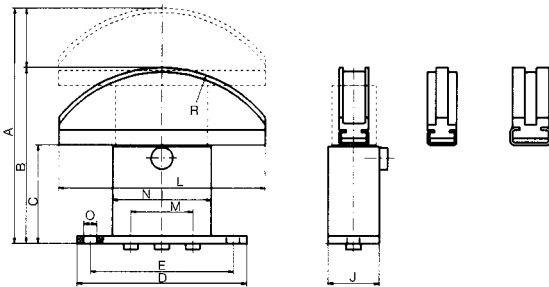

SPANN-BOX® size 1 and 2 with deflecting profile

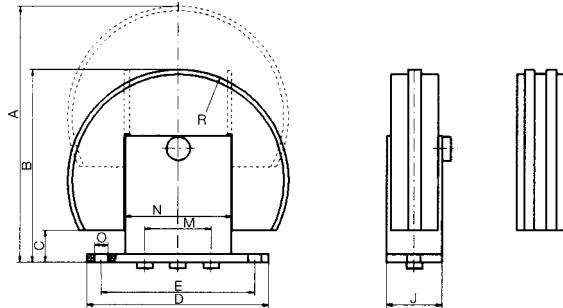

SPANN-BOX® size 1 and 2 with semicircle profile

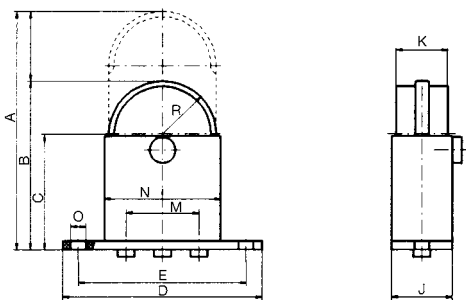

SPANN-BOX® size 2 with block profile

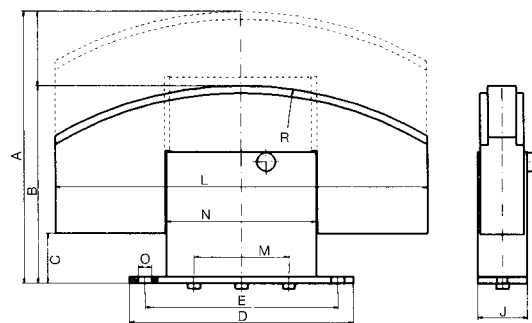

Dimensions	Ind.	A	B	C	D	E	F	G	H	I	J	K	L	M	N	O	R
Size 0		134,0	94,0	58,0	50	38	42	16,2	12,9	6,5	27	20	-	-	-	-	37,5
Size 30		152,5	112,5	63,5	94	80	-	16,5	30,0	6,5	38	-	140	38	-	-	90,0
Size 1, arch profile		158,0	118,0	66,0	115	97	-	-	-	-	35	-	140	42	67	8,5	90,0
Size 1, arch profile	*	173,0	133,0	81,0	115	97	-	-	-	-	40	-	140	42	67	8,5	90,0
Size 1, semicircle profile		137,0	97,0	66,0	115	97	-	-	-	-	35	30	-	42	67	8,5	31,0
Size 1, semicircle profile	*	152,0	112,0	81,0	115	97	-	-	-	-	40	30	-	42	67	8,5	31,0
Size 1, deflecting profile		162,0	122,0	20,0	115	97	-	-	-	-	35	-	-	42	67	8,5	70,0
Size 2, arch profile		209,0	149,0	86,0	180	155	-	-	-	-	40	-	200	76	120	11,0	150,0
Size 2, arch profile	*	229,0	169,0	106,0	180	155	-	-	-	-	40	-	200	76	120	11,0	150,0
Size 2, semicircle profile		203,0	143,0	86,0	180	155	-	-	-	-	40	35	-	76	120	11,0	57,0
Size 2, semicircle profile	*	223,0	163,0	106,0	180	155	-	-	-	-	40	35	-	76	120	11,0	57,0
Size 2, deflecting profile		225,0	165,0	40,0	180	155	-	-	-	-	40	-	-	76	120	11,0	100,0
Size 2, block profile		218,0	158,0	40,0	180	155	-	-	-	-	40	-	300	76	120	11,0	300,0

* long casing

SPANN-BOX® Size 1 with sprocket type KL

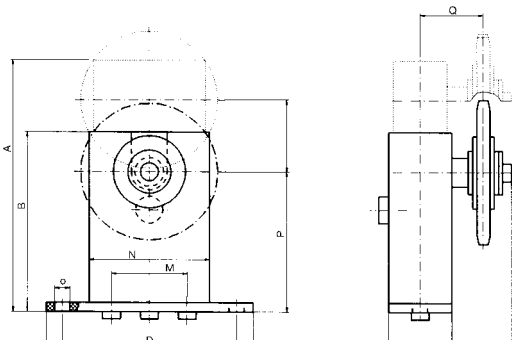

SPANN-BOX® Size 1 with sprocket type KS

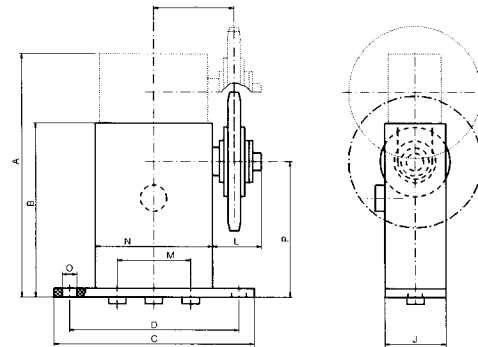

SPANN-BOY® with arch profile

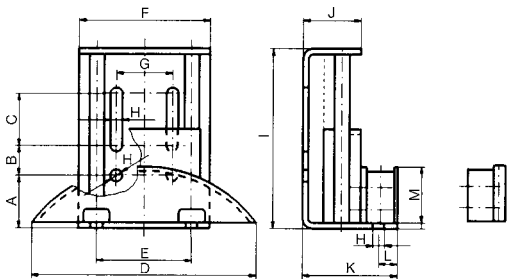

SPANN-BOY® with sprocket

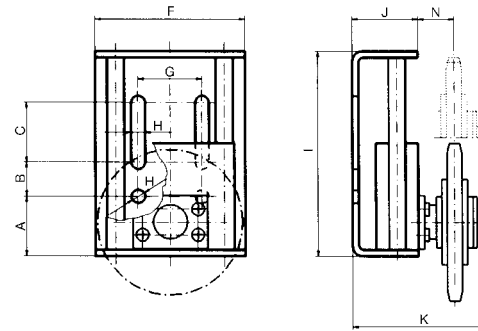

Mounting bracket for SPANN-BOX® size 1 and 2

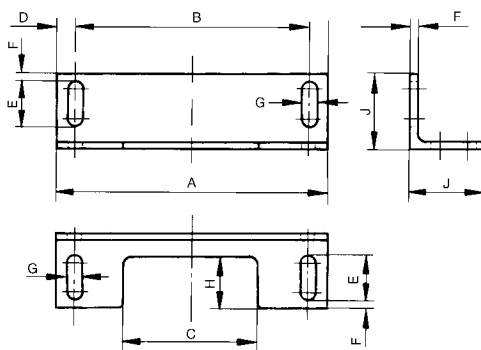

Standard sprockets

Chain-No.	Number of teeth			
	20	21	23	
455	20	21	23	
462	16	17	18	
501	14	15	16	17
513	13	15	16	17

Dimensions	A	B	C	D	E	F	G	H	I	J	K	L	M	N	O	P	Q
SPANN-BOX® size 1 (type KL)	140	100	115	97,0	-	-	-	-	-	35	8,5	35 max.	42	67	8,5	78	35
SPANN-BOX® size 1 (type KS)	140	100	115	97,0	-	-	-	-	-	35	8,5	30 max.	42	67	8,5	78	46
Bracket size 1	115	97	60	9,0	25,0	5	8,5	30,0	-	45	-	-	-	-	-	-	-
Bracket size 2	180	155	90	12,5	30,0	5	11,0	35,0	-	50	-	-	-	-	-	-	-
SPANN-BOY® (arch profile)	28	16	28	120,0	50,8	70	30,0	6,4	96	31	51,0	10	30	-	-	-	-
SPANN-BOY® (with sprocket)	28	16	28	-	-	70	30,0	6,4	96	31	66,0 max.	-	-	17	-	-	-

SPANN-BOX® and mounting brackets made of stainless steel grade 1.4301 on request (Please note: different sizes!).

In order to avoid errors or misunderstandings please supply the following details:

Plate sprocket Type "A"

(for simplex roller chains according to DIN 8187)

1. Number of plate sprockets
2. ⚙-plate sprocket No. (e.g. plate sprocket with 20 teeth for simplex roller chain No. 462 – 1/2" x 5/16" = A 20 462)
3. Custom bore size (fit normal H7)

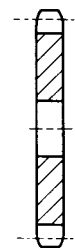

Type A

Sprocket Type "B"

(for simplex, duplex and triplex roller chains according to DIN 8187)

1. Number of sprockets
2. ⚙-sprocket No. (e.g. sprocket with 23 teeth for duplex roller chain No. D 501 – 5/8" x 3/8" = B 23 D 501)
3. Custom bore size (fit normal H7)
4. Groove sizes (for keyways also tightening direction); without additional specifications (e.g. if you merely state groove according to DIN) we will supply sprockets on the basis of DIN 6885 sheet 1
5. Inside threads or pin holes

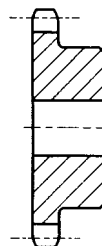

Type B

Sprockets in special designs

(for all chains in our manufacturing line)

1. Number of sprockets
2. Appropriate ⚙-chain No. or ISO No.; alternatively pitch p, inner width b1 (between inner plates) and roller-Ø, pin-Ø or bushing-Ø
3. Number of teeth z
4. Bore size and fit
5. Hub diameter and hub length
6. Hub seat (one-sided or symmetrical); in case of asymmetrical hubs please state the two hub sections up to the sprocket centre
7. Groove sizes (for keyways also tightening direction)
8. Inside threads or pin holes

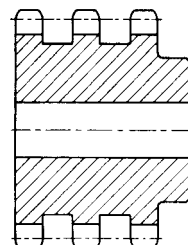
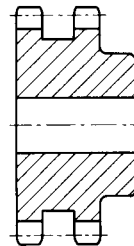

It is advisable to include a precise drawing when ordering sprockets in special designs.

Toothing

(for all chains in our manufacturing line including inverted tooth chains up to p = 25,4 mm)

1. Number of wheel bodies to be toothed
2. ⚙-chain No. or ISO No.; alternatively pitch p, inner width b1 (between inner plates) and roller-Ø, pin-Ø or bushing-Ø
3. Number of teeth

Grooves

1. Number of parts to be grooved
2. Groove sizes (normal DIN 6885 sheet 1)

Lantern gear toothing

1. Number of lantern gears

Chain tensioner SPANN-BOX®

1. Number of chain tensioners SPANN-BOX®
2. ⚙-chain No. or ISO No.
3. SPANN-BOX® size
4. Sliding profile (arch, semicircle or deflecting profile)
5. Spring tension (high or low) and design (ordinary steel or grade 1.4301 [V2 A])

ETP Bushings

1. Number of bushings
2. Order number

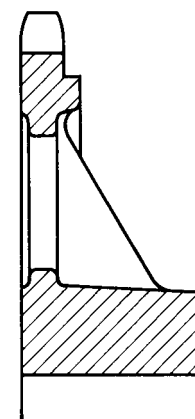

Type B (Cast iron)

Alignment of the sprockets

The wear life of a chain largely depends on the proper alignment of the sprockets. Sprockets must always align exactly. Alignment can be checked by means of a long ruler applied across the sprockets. This check must be repeated several times with the sprockets turned a little further each time. Subsequently, they have to be secured in axial direction.

The shafts must be aligned exactly horizontally. They must be axially parallel and free from runout. In order to avoid vibrations they should be dimensioned according to the weight of the sprockets, the design layout and the loads.

Chain tensioning

Unlike belt drives, chains do not require pre-tensioning, and they should have a slight slack span (see page 124). Chains must not be overtightened, since this would load the drive unnecessarily and lead to premature wear of the chain. However, if chains are fitted too loosely, they tend to "jump off" the sprockets. The chain slack span should be checked after a few weeks. Initial elongation is higher than during the subsequent operation period due to running-in wear.

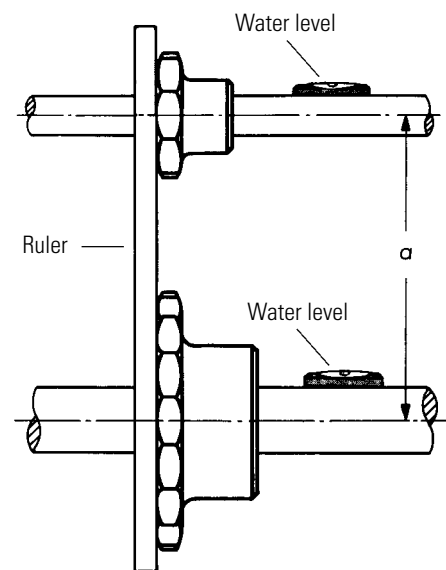

Faulty mounting

Chain runs on laterally offset sprockets

In this case the sprockets are not lopsided, but they are laterally offset. Therefore the chain runs laterally skewed. As a result, the chain plates heavily grind on the teeth of the sprocket and wear quickly. The lateral pressure also loosens the riveting. The chain cannot run smoothly and there is a relatively strong elongation due to the strong wear between pins and bushings.



Tilted position of sprockets

Originally the sprockets were aligned. During tensioning the gear mechanism shifted and is now in an angle to the line of the sprocket on the machine shaft. The consequences are the same as before. Apart from that, axial forces put pressure on the machine and gearing shafts.

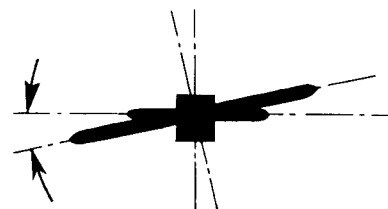

Skewed position of sprockets

The drawing shows that the sprockets are aligned, but that they are skewed, so that the driven sprocket, for example, has now a tilted position against the angle. In this case, the chain is also subject to extreme load and will wear prematurely.





The followings aspects should be considered when selecting a lubricant:

- **Oil or grease lubrication**
Oils are normally used for continuous relubrication. Grease is preferred, if the ambient air contains dust (lime, talcum, flour etc.).
- **Operating temperature**
This is one of the most significant aspects of lubricant selection. The decisive criterion is the temperature in the chain bearing during operation.
- **Viscosity**
Viscosity must be high enough so that all the chain parts are protected against wear and galling. However, despite high viscosity the oil must be sufficiently capable of flow.
The following rules of thumb apply:
 - Low bearing pressure, high chain speed = low viscosity
 - High bearing pressure, low chain speed = high viscosity
 - Low operating temperature = low viscosity
 - High operating temperature = high viscosity
- **Initial lubricant**
It must have excellent corrosion protection qualities and guarantee sufficient wear protection up to the first relubrication. The envisaged operating conditions should be taken into account.
- **Load-bearing properties**
Sufficient load-bearing properties of the lubricating oil film help to reduce wear.
- **Friction point wetting**
The chain lubricant must be able to permeate the lubrication gap autonomously.
- **Chain cooling**
In conjunction with appropriate lubrication procedures certain oils are suitable for cooling. The maximum service temperature of the lubricating oil must never be exceeded.
- **Applications in the food industry**
Lubricants must comply with specific food law requirements.
- **Applications in the textile industry**
Non-drip and non-adhesive oils should be used.
- **Corrosion protection**
This is particularly important for chains used in corrosive environments.
- **Applications in wet environments**
Lubricants must not be washed off by splash water. They must be capable of creep, and supply sufficient corrosion protection even as emulsions.
- **Muffling of chain noises**
Lubricants with higher viscosity ensure better muffling properties than low viscosity lubricants. However, the lubricants must always be sufficiently capable of flow.

- **Contact with elastomers and synthetic materials**
Compatibility with elastomers and synthetic materials must be guaranteed. Compatibility tests are always required.
- **Lifetime lubrication**
Lubrication has been designed in a way that the lubricant will be functioning during the entire lifetime of the chain.
- **Lifetime lubrication for chains is possible, if**
 - the chain load is low
 - the service temperature of the lubricant is considerably underrun
 - the overall operating time is low
 For lifetime lubrication special non-aging chain lubricants have been developed.
- **Ground water hazards**
Please refer to the appropriate safety data specifications.
- **General environmental compatibility**
Please use lubricants, which are biodegradable and particularly environmentally friendly.

Chain lubrication from production to operation

Chain manufacturers	Initial lubrication Corrosion and wear protection Selection of suitable lubrication method
Machine/engine manufacturers	Make already installed chains accessible for manual lubrication Plan chain protection boxes Provide oil pans Design lubrication facilities State reference values for lubrication schedules and lubricant dosage
Machine/engine operators	Inspection of lubrication state and, if necessary, evaluation of lubrication schedules and lubricant dosage Chain cleansing Chain conservation Relubrication

Also refer to the chapter "Maintenance of chain drives" on page 129.

Performance of roller chains as a function of temperature

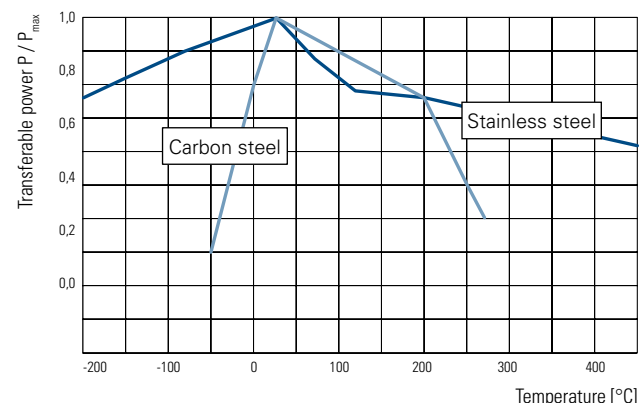



General information

Chains running on sprockets are subject to wear of the joints due to angle-sliding movements of the pins. Therefore efficient lubrication is of utmost importance. Even low-maintenance roller chains with plastic slide bearings should be relubricated occasionally.

Dry running condition (curve 1) causes excessive wear and destroys the chain within a very short time.

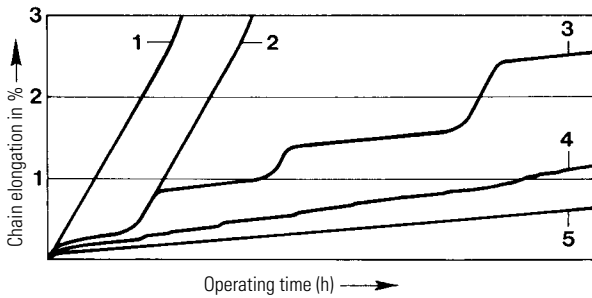

Chain elongation as a function of operating time with different lubrication states

One-time lubrication (curve 2) only delays the wear until the lubricant has been used up.

Intermittent dry running conditions (curve 3) frequently occur with manual lubrication, particularly if deadlines for relubrication have not been met.

Wrong lubrication (curve 4) results in uneven wear and may be caused by inferior, dirty, wrong (unsuitable viscosity) or too little lubricant.

Correct lubrication (curve 5) is crucial for chain drives according to performance diagrams.

Lubrication and degree of efficiency

The following graph shows the influence of lubrication on efficiency.

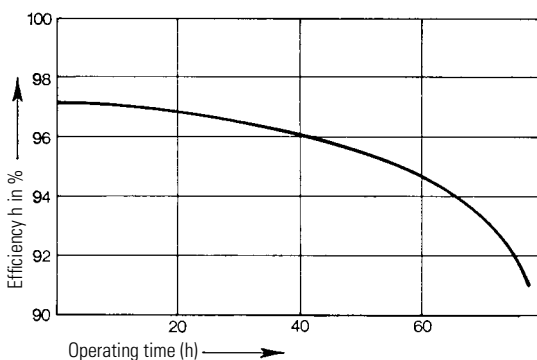

Degree of efficiency as a function of operating time with one-time lubrication (according to Worobjew)

Lubricants

The selection of an appropriate lubricant depends first of all on the type of lubrication.

Low viscosity mineral oils are particularly suitable for chain drives.

Ambient temperature °C	Viscosity group of lubricant
- 5 up to + 25	ISO VG 100 (SAE 30)
25 up to 45	ISO VG 150 (SAE 40)
45 up to 65	ISO VG 220 (SAE 50)

For higher temperatures (e.g. furnace chains) graphite or molybdenum disulfide (MoS₂) applied either as additive or spray will facilitate lubrication.

Low-viscosity or hardened grease products with a drop point of 70° C are also suitable for manual lubrication. In special cases liquidised grease may be sprayed on. Initial operation can start immediately after evaporation of the volatile carrier substance.

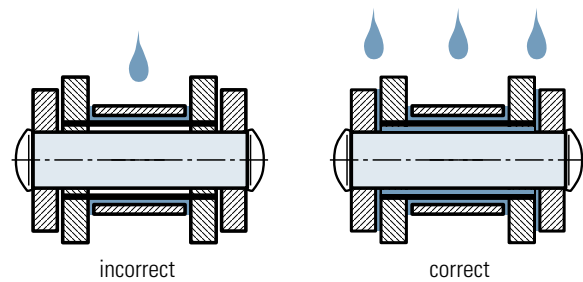

It is very important that the lubricant reaches the joints (pins, bushings), which are subject to wear.

Recommendations for lubrication

The type of lubrication depends on the chain pitch and the chain speed.

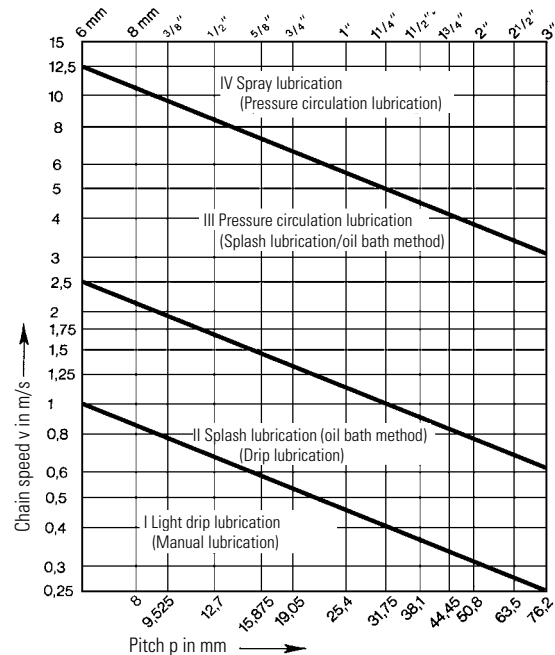

The lubrication types, which are not in brackets, are preferable to those in brackets (permitted).

In order to achieve a long wear life and high cost effectiveness for chain drives in lubrication range I (light drip lubrication or manual lubrication) relubrication schedules must be determined by tests.



Manual lubrication

This type of lubrication by means of oil can and brush is not very safe and therefore only suitable for chains with occasional operation or for secondary drives and low chain speeds.

Sufficient lubrication should take place at least once a day (if possible every 8 operating hours). Lubricant colouration may not occur.

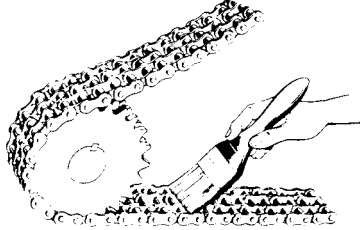

Spinning disk lubrication

With this type of lubrication the chain operates above oil level. A disk submerging into the lower oil level (peripheral velocity between min. and max. 40 m/s) centrifuges oil against the casing walls from where it continuously runs down onto the chain via drip rails.

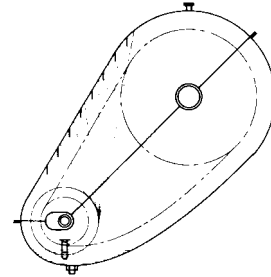

Splash lubrication (oil bath method)

There is just enough oil in a sufficiently sized protection box (the worn and elongated chain must not be able to hit against the casing wall) to allow the chain plates to submerge into the bath up to the rollers or the bushings respectively.

Higher submerging depths cause the oil to heat up and lead to untimely oxidation of the oil.

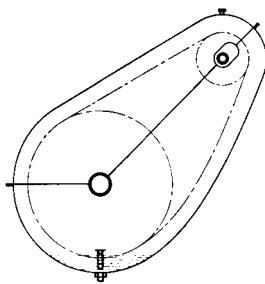

Spray lubrication

Spray lubrication is very similar to pressure circulation lubrication. Instead of a lubrication shower, however, lubrication spray valves atomise the oil into aerosol form, and thus the fine oil mist can reach every single chain joint.

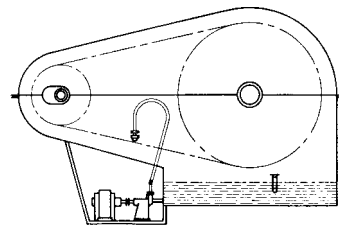

Drip lubrication

Drip lubrication by means of wick oilers, needle oilers or drip oilers is only suitable for low load bearing drives. Sufficient lubrication of the joint surfaces must be ensured. Lubricant colouration may not occur.

Pressure circulation lubrication

This type of lubrication is suitable for fast-running drives and high loads. The oil can be supplied via a connection to an existing pressure oil pipe or via an extra pump. By means of a lubrication shower situated near the large sprocket, oil is sprayed onto the inner side of the chain return strand in running direction over the whole width of the chain. High load-bearing drives need a second shower for cooling with the oil to be sprayed onto the pull strand. The oil quantity depends on the drive size and the amount of heat to be dissipated.

Lubrication overview

Lubrication range	Chain speed m/s	Lubrication a) favourable b) permitted	Transmissible power			
			correct lubrication (favourable/permitted)	insufficient lubrication without contamination	insufficient lubrication with contamination	without lubrication*
I	up to ≈ 1	a) Light drip lubrication b) Manual lubrication/grease lubrication	100 %	60 %	30 %	15 %
II	up to ≈ 2,5	a) Splash lubrication (oil bath method) b) Drip lubrication		30 %	15 %	
III	up to ≈ 12,5	a) Pressure circulation lubrication b) Splash lubrication (oil bath method), if possible with spinning disk		not permitted		
IV	above 12,5	a) Spray lubrication b) Pressure circulation lubrication (possibly with oil cooling system)				

* a wear life of 15 000 hours cannot be guaranteed!

WIPPERMANN Lubrication

Product	Oil	Grease	Spray	Application °C from to	Technical features
WKS-C				- 10 + 100	WIPPERMANN standard lubrication Mineral oil-based soap-free chain grease, with wax and product-specific additives, for extreme requirements as to corrosion and wear protection Water resistant
WKS-W				0 + 80	Lubrication wax for chains "Quasi dry" non-tacky lubrication film Wear protection High corrosion protection Good adhesive properties Excellent water resistance
WKS-Rapid				- 15 + 120	White chain lubricant Difficult to centrifuge off Protects against corrosion and wear It has absorbing and rinsing properties and provides effective lubrication Resistant to water and vapour Quite resistant to acids and bases
WKS-D				- 10 + 80	Corrosion protection oil Chlorine-free lubricant made with mineral oil raffinates and corrosion protection additives; thin, waxes and pressure-resistant lubrication with anti-wear additives Excellent corrosion protection
WKS-H1				- 10 + 140	Chain lubricant for hygienic and clean lubrication Fully synthetic high performance chain lubricant for the pharmaceutical, food and beverage, cosmetics, feeding stuff, and tobacco industries as well as their suppliers. Complies with U.S. requirements as to guidelines of sec. 21 CFR of FDA regulations Increased performance range achieved by a combination of high-quality, mineral oil free synthetic base oils with a high-capacity additives package. <u>Nonfood Compounds Program Listed H1, NSF Reg # 143954</u>
WKS-Plus				- 10 + 240	High-temperature lubricant Fully synthetic, temperature-stable high-performance oil especially developed for chain lubrication Improved protection against wear, ageing and corrosion due to a combination of synthetic ester oils and additives This product combines the special requirements of chain lubrication with demands on lacquer compatibility.
WKS-HT				- 10 > 250 (as of +300 °C dry lubrication)	High-temperature lubricant Polyalkylene glycol oil, containing solid lubricants, for chain lubrication at high temperatures Excellent wetting properties and creep behaviour High stability This product can be used at temperatures of up to 500°C; above 200°C there is a gradual transition to dry lubrication.
WKS-T				- 55 + 90	Lubricant for environments with low temperatures Fast biodegradable and low-temperature multi-purpose oil based on synthetic ester with excellent wear protection The product has a low evaporation rate and is characterised by its excellent viscosity-temperature behaviour; it is also highly age resistant
WKS-Spezial				- 10 + 80	Chain spray for relubrication Mineral oil-based chain spray with synthetic wax, corrosion protection and anti-wear additives (propellant: propane / butane pressure gas mixture) For relubrication of open drive chains, conveyor chains in conveying systems as well as for load chains

All lubricants supplied by WIPPERMANN are free from chlorine and silicone.

Detailed product description and safety data sheets on request.

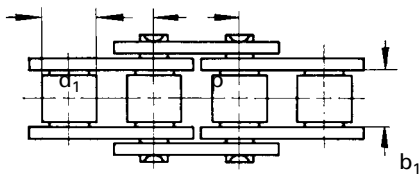

Steel link chains

Generally, steel link chains can only operate on one plane, and they are primarily used as drive elements for chain drives.

They are precisely determined by three main measurements:

p = **Pitch** is the distance from pin centre to pin centre.

b_1 = **Inner width** is the distance between the inner plates.

d_1 = **Roller diameter, bushing diameter or pin diameter** is the outer dimension of the cylindrical parts between the inner plates.

The characteristic feature of a steel link chain is the chain joint.

It consists of an outer and an inner link. On this joint the calculated bearing area equals the projection of the pin onto the bearing area of the inner link. It has a different size depending on the type of chain.

In the following overview the characteristic features of various types of steel link chains are briefly described.

Galle chains

Galle chains were named after their inventor André Galle (1761-1841). A Galle chain is the simplest type of steel link chain.

The plates rotate directly on the pin lug. With this type of chain the bearing area is very small.

Therefore the chain speed should not exceed 0,3 m/s.

Consequently, Galle chains are less suitable for power transmission, and they are almost exclusively used as load chains (e.g. counterweight chains, lock chains and tack chains).

Galle chains on request (see page 76)

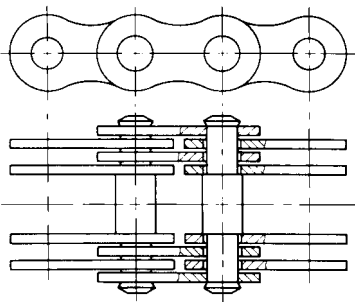

Leaf chains

Leaf chains in normal design or reinforced design are used as load chains in cranes, hoisting gear and lifting equipment as well as for counterweights, e.g. on machine tools, and also to transmit back-and-forth movements.

The plates of leaf chains are punched from high-grade steel and are subsequently hardened and tempered to guarantee high fatigue strength. Very narrow tolerances ensure that all plates bear the same load proportions. Pins made of high alloy case-hardened steel are tempered to achieve high wear resistance. The tightly adjoining plates are designed in various combinations and rotate on the pins.

One special design is the heavy-duty type series U. On chains of this type all plates are mounted with a sliding fit and are also secured with laterally attached riveted disks. This design guarantees an even load distribution and reduces the bending load of the pins. These chains were especially developed for heavy loads and operations under harsh conditions. Due to their high fatigue strength they are particularly suitable for such application areas.

Due to their design (no tooth meshing) leaf chains cannot transmit torques. Their force direction, however, can easily be deflected by means of rollers. Even with a small working width they have a high breaking load.

Dimensions as of page 68 ff.

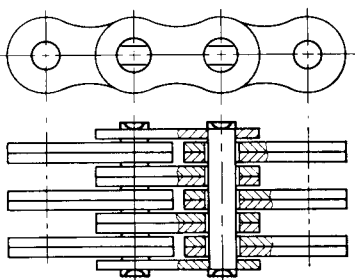

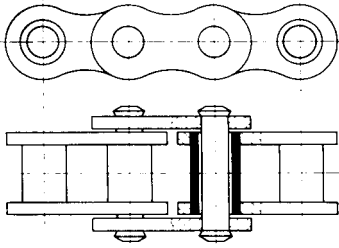

Bush chains

Bush chains are more wear-resistant than Galle chains. The inner links consist of two inner plates with two force-fitted bushings. The outer links consist of two outer plates with two force-fitted and riveted pins.

Chain speeds of up to 5 m/s are possible depending on the pitch.

Due to their robust design bush chains are mainly used as drive and conveyor chains, particularly where there are rough operating conditions, e.g. in mining or construction site equipment.

For dimensions see page 47.

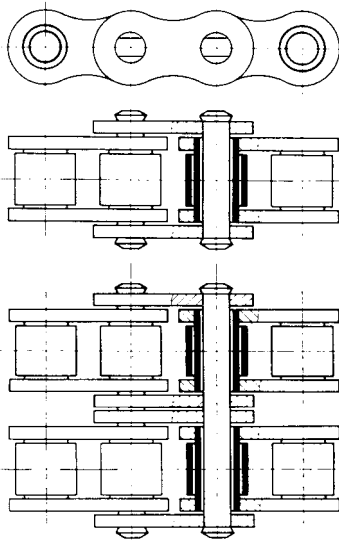

High performance roller chains

Compared to bush chains, high performance roller chains are of better quality due to the use of higher steel grades and heat treatment. Furthermore, they are produced with higher accuracy and narrower tolerances. The visible difference is the rollers, which are mounted on the bushings with running fit, and which absorb the meshing impact in the sprocket and thus reduce sprocket wear. Plates and rollers are hardened and tempered in order to achieve high fatigue strength, whereas bushings and pins, which are subject to wear, are case-hardened.

For high power transmission under restricted mounting conditions multi-strand roller chains can be used. This means that several simplex roller chains are connected by means of an end-to-end pin to form one single unit. Duplex and triplex chains are standardised.

Roller chains can be employed universally and are therefore the most common chain type. They are not only used as drive and gear chains in machine construction, but also in special designs with attachments for transport and conveyance purposes or instead of rack and pinion arrangements.

Roller chains RF made of stainless and acid-resistant steel grade 4301 have proved their value on corrosion-endangered drives and because of their anti-magnetic properties for many years. They are mainly used in the chemical, beverage and food industry.

Dimensions as of page 10 ff.

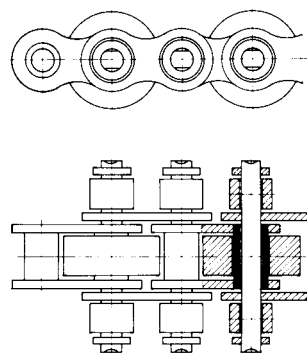

Accumulator chains

Accumulator chains are employed, when accumulation of piece goods during transportation is required. The chain runs on lateral support rollers, whereas the conveyor roller in the middle runs freely.

The particular advantages of this type of chain lie in the simple control, the exact guiding possibilities as well as in the smooth transition from one direction to another without abrupt acceleration. During intentional or unintentional accumulation of the transported piece goods no excessive impact pressure is put on the following transport units since the power and free conveyor chain will continue to run smoothly under the goods until the end of the accumulation, when transportation will continue due to friction.

For dimensions see page 38, 39, 60 - 62.

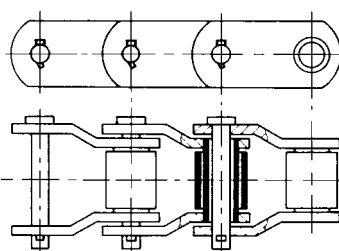

Cranked link chains (Rotary chains)

Cranked link chains (Rotary chains) are in fact roller chains, but only cranked plates are used. These plates help to give the chain a high amount of elasticity so that load impacts can easily be absorbed. It is also quite straightforward to repair cranked link chains since each individual link can be replaced.

Cranked link chains (Rotary chains) are mainly employed for applications with intermittent impacts and where the drive is exposed to rough soiling, e.g. in excavation machinery, crawlers for excavators and dozers or drilling equipment.

Cranked link chains (Rotary chains) on request 76)



- High efficiency:** η up to 0,98 with a properly lubricated chain under normal circumstances and with a drive working under full load.
- Long wear life:** \approx 15000 operating hours if the correct drive was selected and with appropriate maintenance.
- Extensive power and speed range:** P up to 225 kW with simplex roller chain $p = 76,2$ mm
Power diagram for roller chains according to ISO 606 see page 120 ff
- Long shaft distance:** The shaft distance (usually between 30 times and 50 times the pitch) has no fixed measurements. It can easily be adjusted by shortening or lengthening of the chain, even after completed assembly, in order to meet altered construction requirements.
- No slip:** In contrast to friction-locked drives chain drives have no slip. In motor vehicles, camshaft drives with chains guarantee exact valve timing.
- Multiple transmission ratios:** The transmission ratio:
$$i = \frac{n_1}{n_2} = \frac{z_2}{z_1} \quad (\text{usually up to approx. } 7:1)$$

(in special cases up to 10:1 in one step possible)
remains constant during the entire operation period due to its positive locking connection. However, it may be easily altered by simply changing the sprockets and keeping the shaft distance.
- High load capacity:** For the permissible bearing pressure with recommended lubrication please refer to the table on page 122.
- Elastic properties:** Roller chain drives have a high elasticity, because of the plate material and the lubrication layer between rollers, pins and bushings.
- Versatile applications:** Roller chains are mainly used as drive elements for power transmission or as load chains; equipped with special links they can also be used for transportation and conveyance purposes. One chain is able to simultaneously drive several shafts with the same or opposite rotational direction at the same or at different speeds. It can also be employed as a rack and pinion assembly (lantern gears).
- Cost effectiveness:** Roller chains do not need to be pre-tensioned. Therefore there are only minor bearing loads. Space-saving construction, simple mounting, low service and maintenance costs make chain drives very economical.



Designation	Symbol	Unit	Basic equations
Input speed	n	min ⁻¹	
Operating factor	k		$k = f_y \cdot f_i \cdot f_z$
Minimum tensile strength	F _B	N	see chain tables
Torque	M	Nm	$M = \frac{9550 P}{n} = \frac{F \cdot d_0}{2000}$ in Nm
Correction factor for impact loads	f _y		see page 118
Correction factor for transmission ratio	f _i		see page 119
Correction factor for shaft distance	f _a		see page 119
Correction factor for number of teeth	f _z		see page 119
Bearing area	f	cm ²	see chain tables
Bearing pressure	p _r	N/cm ²	$p_r = \frac{F}{f}$ see page 117
Speed	v	m/s	$v = \frac{z \cdot p \cdot n}{60\,000}$ in m/s
Weight of chain per meter	q	kg/m	see chain tables
Power	P	kW	$P = \frac{F \cdot v}{1000} = \frac{M \cdot n}{9550}$ in kW
Diagram power	P _c	kW	$P_c = P \cdot k$ in kW
Safety factor	S		$S = \frac{F_B}{F_G}$
Impact coefficient	Y		see page 118
PCD	d ₀	mm	$d_0 = \frac{p}{\sin \frac{180^\circ}{z}}$ in mm
Pitch	p	mm	see chain tables
Transmission ratio	i		$i = \frac{n_1}{n_2} = \frac{z_2}{z_1}$
Shaft distance	a	mm	
Number of teeth	z ₁ , z ₂		
Tensile force	F	N	$F = \frac{1000 P}{v} = \frac{2000 M}{d_0}$ in N
Tensile force, dynamic	F _d	N	$F_d = F \cdot f_y$ in N
Tensile force, centrifugal	F _F	N	$F_F = q \cdot v^2$ in N
Tensile force, total	F _G	N	$F_G = F_d + F_F$ in N



Dimensioning of leaf chains

The transmissible load as well as the operating conditions i.e. type of load, chain speed, chain activity rate, impact level and operating temperature must be considered when selecting a leaf chain.

The permissible dynamic tensile force depends on the fatigue strength of plates and pins. As an indirect benchmark the breaking load of chains is used, and thus fatigue strength is taken into account by including a sufficient safety factor. Type and design of the chain determine the safety factor to be selected. In order to be able to dimension leaf chains, the tensile force F as well and the operating conditions for assessing

further dynamic loads have to be known. The tensile force F , the factor f_1 for the operating conditions and the safety factor S are crucial to calculate the required minimum breaking load F_B of the chain.

The safety factor S is subject to the regulations stipulated by various authorities and the German Technical Inspection Authority (TÜV). If there are no specific regulations, the factor S can normally be selected between 7 and 12 according to the type and design (combination of plates) of the respective chain.

Calculation of the minimum breaking load F_B

$$F_B \geq F \cdot f_1 \cdot S$$

$$F_B \geq F \cdot f_1 \cdot (n_{LW} \cdot 100 \cdot f_u)^{0,1}$$

F_B : Minimum tensile strength of chain

F : Tensile force in chain

f_1 : Operating factor

S : Safety factor

n_{LW} : No. of load cycles (fatigue limit: $n_{LW} = 10^7$)

f_u : Correction factor for PCD

$$S = (n_{LW} \cdot 100 \cdot f_u)^{0,1}$$

$$d_0 = d_u + g$$

d_0 : PCD of deflection

d_u : Diameter of contact surface of deflection roller

g : Plate height

p : Chain pitch

Load type	f_1
no impact	1,00
uniform, single slight impacts, slightly swelling load	1,25
repeated slight impacts, moderately swelling load	1,37
repeated slight impacts, highly swelling load	1,59
repeated high impacts, moderately swelling load	1,72
repeated high impacts, moderately swelling load	1,85

PCD d_0	f_u
$4,5 \cdot p$	9,10
$5,0 \cdot p$	7,14
$5,5 \cdot p$	5,95
$5,8 \cdot p$	5,43
$6,0 \cdot p$	5,13
$6,5 \cdot p$	4,52
$7,0 \cdot p$	3,79
$7,5 \cdot p$	3,70

Chain speed
up to 5 m/min.
> 5 ... 10 m/min.
> 10 ... 30 m/min.

Minimum safety factor S
7
10
12

Further details:

- For temperatures as of 100 °C higher safety factors apply. On request we will give you more detailed information as to these safety factors.
- The higher the number of plates the higher the safety factor S should be.
- For single lacing the safety factor should be higher than for double lacing.

Calculation of the bearing pressure p_r

$$p_r = \frac{F \cdot f_1}{f} \leq p_{rzul}$$

- p_r : Bearing pressure
 f : Chain joint area
 p_{rzul} : Permissible pressure in bearing area
 F : Tensile force in chain
 f_1 : Operating factor

Check and maintenance of leaf chains

Permissible wear elongation may be max. 3 %. If a chain has elongated by 3 % caused by wear in the joints, it must be replaced. Therefore leaf chains must be subjected to wear checks at regular intervals. These checks should comprise:

1. Check of elongation in working area (max. 3 %)
2. Check of play in joints (by pushing the chain together, pulling it apart again and measuring the length difference)
3. Check of pin fit in outer plates

Deflection of leaf chains

$$d_0 = d + g$$

$$d_a = d_u + 2 \cdot k$$

$$d_R \geq d_u + 2 \cdot g$$

$$b_1 \geq l_1$$

p : Chain pitch

d_0 : PCD of deflection

d_R : Diameter with fitted chain

b_1 : Width of contact surface

g : Plate height

$$k = 0,86 \cdot \frac{g - d_2}{2}$$

$$b_2 \geq 1,2 \cdot b_1$$

d_u : Diameter of contact surface of deflection roller

d_a : Outer diameter of roller

b_2 : Roller width

l_1 : Width of chain over pin

k : Height of collar

d_2 : Pin diameter

Chain speed

Chain speed		P_{rzul}	
up to 5	m/min.	14000	N/cm ²
> 5 ... 10	m/min.	12000	N/cm ²
> 10 ... 30	m/min.	9000	N/cm ²

In case of permanent tensile force (counter balances) p_{rzul} must be smaller than with a regularly released chain.

4. Check for fatigue failure (cracks in plates)
5. Check for deformed plates
6. Check for corrosion (pitting corrosion)
7. Check of flexibility (sufficient lubrication)

Leaf chains must be relubricated at regular intervals (see as of page 105 - 108). Sufficient lubrication will considerably reduce wear and increase the wear life by a multiple.

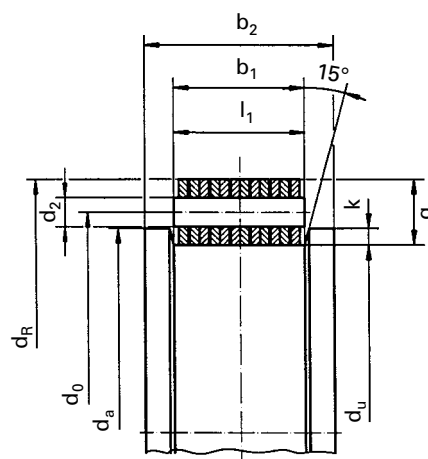

Leaf chains heavy duty design U

$$k^* = 0,86 \cdot \frac{g - d_3}{2}$$

$$d_a^* = d_u + 2 \cdot k^*$$

d_a^* : Outer diameter of rollers (for chains with washers)

k^* : Height of collar (for chains with washers)

d_3 : Diameter of washers

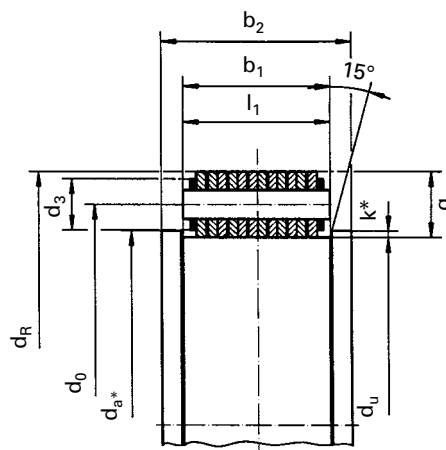

General information

The selection criteria discussed below apply to general mechanical engineering applications. Application areas such as hoisting devices (e.g. for lifting loads etc.) are excluded.

The chain life is exclusively determined by its wear behaviour. Wear occurs in the chain joints on pins and bushings. Primarily, wear depends on the chain tensile force, on deflection movements of links running along the sprockets, on the bearing area as well as on lubrication and on the number of rotations.

Therefore the chain must be dimensioned in a way that prevents overloads and fatigue failure. This means that plates and pins resist the transmissible tensile forces, rollers withstand the loads occurring when meshing with the sprocket, and that wear in the joints and on the tooth flanks remains within permissible limits.

Chain drives only have a satisfactory wear life, if the sprockets align, if they are subjected to sufficient lubrication, if there are re-tensioning facilities to compensate for the elongation occurring during operation, and if vibrations of the pull and return strands or torsional vibrations of the entire drive are eliminated. With new chains, the slack span in the return strand should be about 1 % of the shaft distance.

Basic information for chain selection

In order to be able to select a chain, at least the following values for power transmission must be known:

1. Transmissible power P in kW
2. Speed of driving sprocket n₁ in min⁻¹
3. Transmission ratio $i = n_1/n_2 = z_2/z_1$
4. Operating conditions of drive (Stoßbeiwert f_y)
5. Shaft distance a in mm

If possible, sprockets with at least 17 teeth should be selected. For chain drives with medium speeds or more, and for maximum loads we recommend sprockets with 21 tempered teeth. Normally, the maximum number of teeth should not exceed 150.

The optimal shaft distance is 30 times p - 50 times p and should allow an angle of lap of at least 120° on the smaller sprocket. On chain drives with an inclination of more than 60° clamping-jockey sprockets or automatic chain tensioners must be mounted to ensure the required chain tension.

There often is a choice between a simplex roller chain with a longer pitch and a multiplex roller chains with a shorter pitch. However, chain drives with multiplex roller chains allow smaller sprocket diameters in restricted spaces. They cause less noise and fewer vibrations than chains with a long pitch, which run on sprockets with fewer teeth.

Factor f_y to take into account specific operating conditions

Driving motor / engine	Driven equipment		
	Centrifugal pumps and compressors Printing machines Conveyors with regular infeed Paper calenders Escalators Stirring devices for liquids Rotary driers Ventilators Generators (apart from welding generators)	Piston pumps and compressors with three or more cylinders Concrete mixers Conveyors with irregular feed Screw conveyors Rolling mills direct Saws and reciprocating saws Stirring devices for solid matter Spinning and rinsing machines Brick work machines	Planing machine and pulp grinders Excavators and other building plant Roller crushers Pulling machines Welding generators Choppers Rubber processing machines Piston pumps and compressors with one or two cylinders Gas or oil drill poles Dough mixers
Electric motors in continuous operation Internal combustion engines with hydraulic coupling Water, steam or gas turbines	1,0	1,4	1,8
Electric motors, which are repeatedly started and stopped with fewer than 10 cycles/min Internal combustion engines with six or more cylinders and mechanical coupling	1,1	1,5	1,9
Electric motors, which are repeatedly started and stopped with more than 10 cycles/min Internal combustion engines with fewer than six cylinders and mechanical coupling	1,3	1,7	2,1



Table of tolerable bearing pressures with recommended type of lubrication

Chain speed in m/s	Bearing pressure p_i in N/cm ² with number of teeth z on smaller sprocket														
	11	12	13	14	15	16	17	18	19	20	21	22	23	24	≥ 25
0,1	3080	3120	3170	3220	3270	3300	3320	3350	3400	3430	3450	3480	3500	3530	3550
0,2	2810	2850	2880	2930	2980	3000	3030	3060	3100	3120	3140	3170	3190	3220	3240
0,4	2700	2740	2780	2830	2870	2890	2910	2950	2980	3000	3020	3070	3070	3100	3120
0,6	2580	2620	2650	2700	2740	2760	2780	2820	2850	2870	2890	2910	2930	2960	2980
0,8	2490	2490	2560	2610	2650	2670	2680	2720	2750	2770	2790	2810	2830	2860	2880
1,0	2380	2420	2450	2490	2520	2540	2560	2590	2620	2640	2660	2680	2700	2720	2740
1,5	2290	2330	2360	2400	2430	2450	2470	2500	2530	2550	2570	2590	2610	2630	2650
2,0	2210	2240	2270	2310	2350	2370	2380	2410	2440	2460	2470	2490	2510	2530	2550
2,5	2130	2160	2190	2230	2260	2280	2290	2320	2350	2370	2380	2400	2440	2470	2500
3,0	2050	2080	2110	2140	2170	2190	2210	2240	2260	2290	2320	2350	2380	2420	2460
4,0	1740	1830	1920	2000	2070	2100	2130	2160	2180	2220	2260	2300	2340	2380	2420
5,0	1400	1550	1690	1770	1840	1910	1970	2010	2050	2100	2150	2180	2210	2240	2280
6,0	1050	1230	1410	1540	1640	1730	1810	1880	1950	1990	2040	2070	2110	2140	2180
7,0	850	1000	1150	1280	1400	1510	1620	1740	1850	1870	1900	1940	1980	2020	2060
8,0	-	800	1020	1110	1200	1310	1420	1560	1700	1740	1780	1820	1870	1910	1960
10,0	-	-	810	900	1020	1110	1200	1320	1430	1460	1500	1570	1640	1700	1770
12,0	-	-	-	-	820	910	1070	1170	1260	1300	1350	1410	1480	1540	1600
15,0	-	-	-	-	-	-	890	970	1050	1100	1150	1210	1270	1330	1400
18,0	-	-	-	-	-	-	-	-	880	960	1050	1110	1180	1240	1300

This applies to chains according to ISO 606 with pins and bushings made of case-hardened steel.

Annotation: If requested, we can supply chains made of steel grades that can be subjected to particularly high bearing pressure.

Ratio between speed n and chain pitch p for $z_1 = 25$

Pitch p	mm	8	9,525	12,7	15,875	19,05	25,4	31,75	38,1	44,45	50,8	63,5	76,2
	inch	-	3/8"	1/2"	5/8"	3/4"	1"	1 1/4"	1 1/2"	1 3/4"	2"	2 1/2"	3"
Speed n_{max}	min ⁻¹	6000	5000	3600	2700	2000	1500	1200	900	700	550	450	300

Factors to be considered in case of different operating conditions

Impact coefficients f_y (see table on page 118)

Number of teeth of driving sprocket

z	11	13	15	17	19	21	23	25	31	37
f_z	1,80	1,50	1,30	1,13	1,00	0,90	0,81	0,74	0,60	0,50

Diagram power $PC = P \cdot f_y \cdot f_z \cdot f_i = P \cdot k$

Transmission ratio

i	1 : 1	2 : 1	3 : 1	5 : 1
f_i	1,22	1,08	1,00	0,92

Shaft distance

a	10 p	20 p	40 p	80 p
f_a	1,30	1,15	1,00	0,85

Diagrams 1, 2 and 3 are typical power diagrams for chain drives with the following operating conditions:

- a) Chain drive with two sprockets on parallel, horizontal shafts
- b) Driving sprocket with 19 teeth
- c) Simplex chain without a cranked link
- d) Chain length 120 links (for shorter chains the chain life decreases proportionally)
- e) Speed reducing ratio from 1:3 up to 3:1
- f) 15000 h expected wear life; 15000 operating hours only with a maximum of 3 % elongation caused by wear
- g) Operating temperature between - 5°C and + 70°C
- h) Sprockets aligned and chain tensioned according to specifications (see page 107, 127, 128)
- i) Regular operation without overload, impacts or frequent restarts
- j) Clean and sufficient lubrication (see page 108 - 111)

Power diagram for roller chains according to ISO 606 (European type)

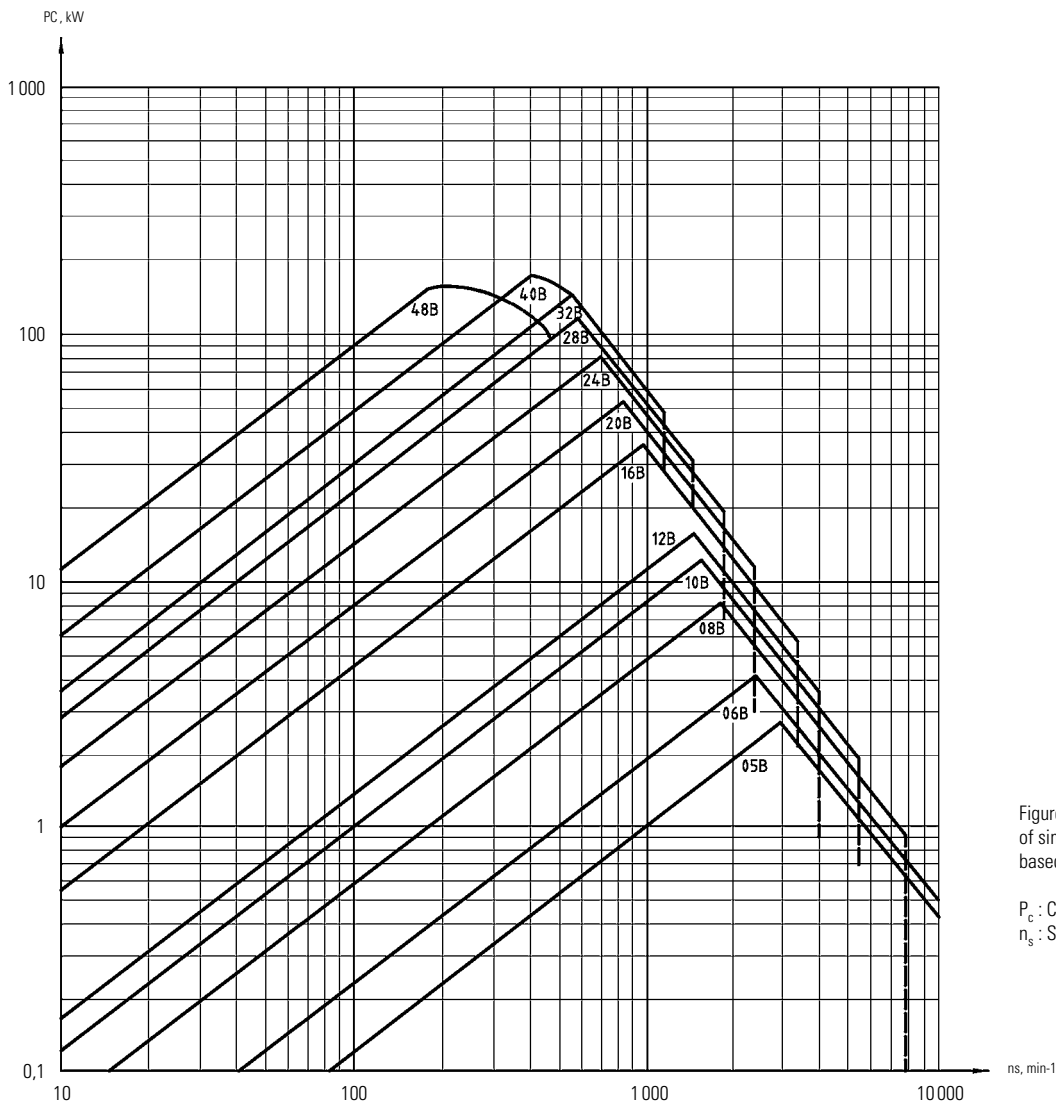

Figure 1: Typical power diagram for selection of simplex chains type B according to ISO 606, based on a sprocket with 19 teeth

P_C : Corrected power
 n_s : Speed of smaller sprocket

Annotation 1: The nominal values for the performance of duplex roller chains can be calculated by multiplying the P_C -value for simplex chains with the factor 1,7.

Annotation 2: The nominal values for the performance of triplex roller chains can be calculated by multiplying the P_C -value for simplex chains with the factor 2,5.

In case of different operating conditions, the value of the transmissible power "P" must be multiplied with the respective factor "k" in order to be able to select the appropriate chain from the diagram on the basis of the

Diagram power $P_C = P \cdot k$

The operating factor "k" takes into account the operating conditions of the drive, the number of teeth on the small sprocket, the transmission ratio and the shaft distance.

Longer wear lives can be achieved by transmitting less power than shown in the diagram.

If roller chains are operated with very low speeds or idly (e.g. as load chains), the tensile force must be calculated according to the formula $F_d = F \cdot f_y$ zu berechnen.

The safety factor should be at least $S = 7!$

Power diagram for roller chains according to ISO 606 (American type)

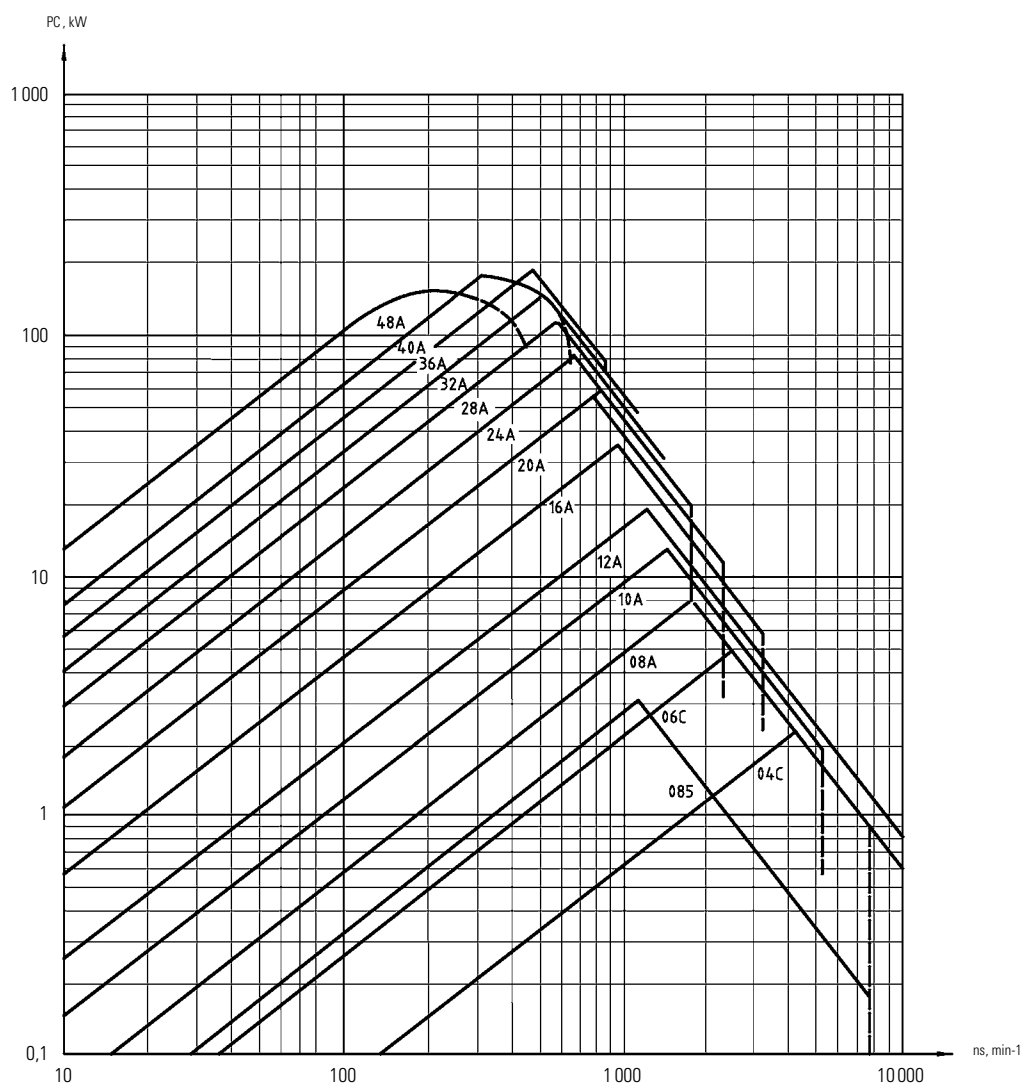

Figure 2: Typical power diagram for selection of simplex chains type A according to ISO 606, based on a sprocket with 19 teeth

P_C : Corrected power
 n_s : Speed of smaller sprocket

Annotation 1: The nominal values for the performance of duplex roller chains can be calculated by multiplying the P_C -value for simplex chains with the factor 1,7.

Annotation 2: The nominal values for the performance of triplex roller chains can be calculated by multiplying the P_C -value for simplex chains with the factor 2,5.



Power diagram for roller chains according to ISO 606 (American type, reinforced)

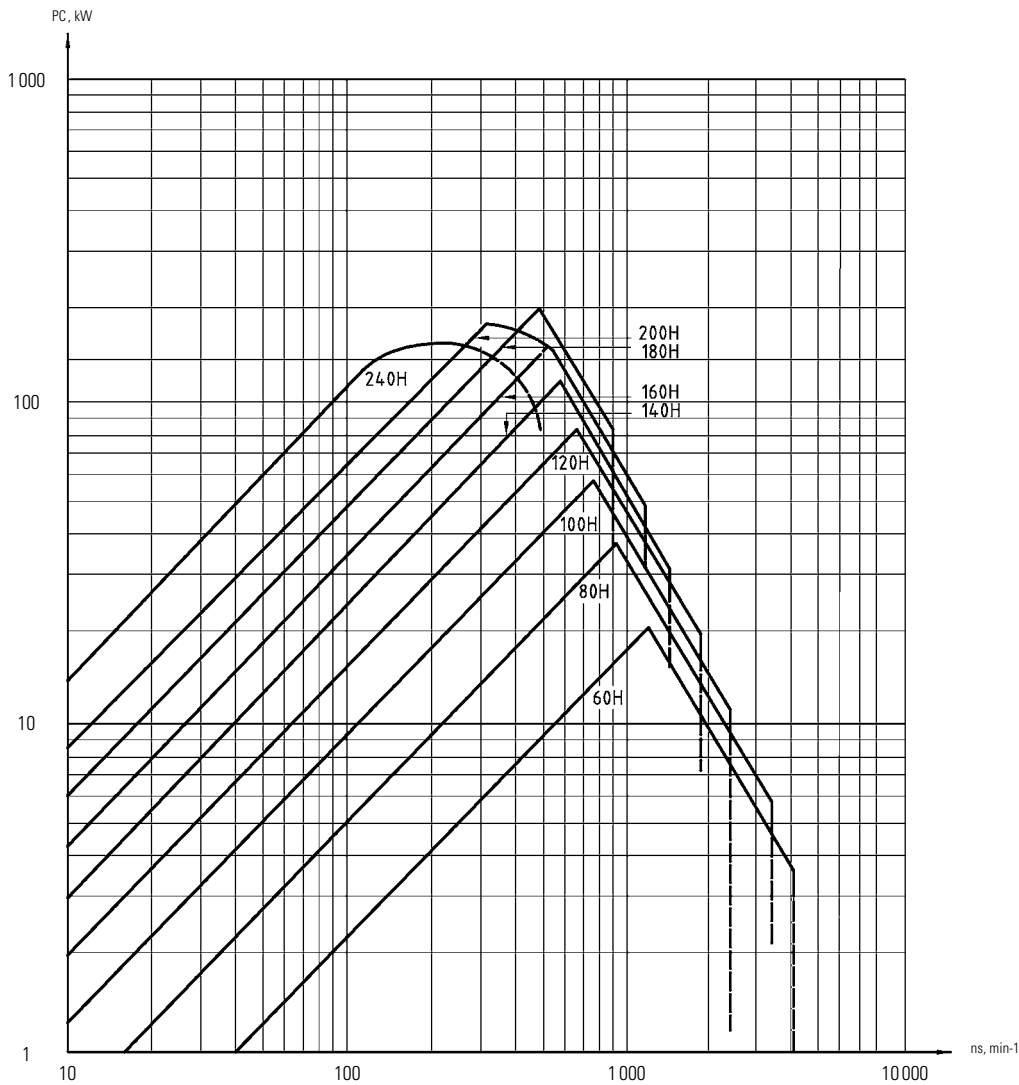
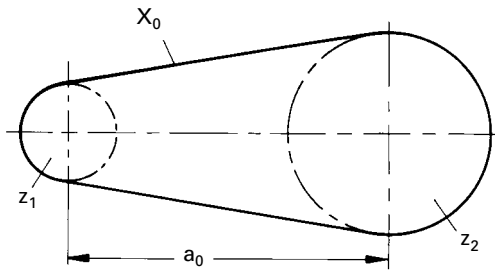

Figure 3: Typical power diagram for selection of reinforced simplex chains type A according to ISO 606, based on a sprocket with 19 teeth

P_C : Corrected power
 n_s : Speed of smaller sprocket

Annotation 1: The nominal values for the performance of duplex roller chains can be calculated by multiplying the P_C -value for simplex chains with the factor 1,7.

Annotation 2: The nominal values for the performance of triplex roller chains can be calculated by multiplying the P_C -value for simplex chains with the factor 2,5.



- X = Chain length in links
 X_0 = Theoretical chain length
 a = Shaft distance in mm
 a_0 = Theoretical shaft distance
 p = Pitch in mm
 z_1 = Number of teeth on small sprocket
 z_2 = Number of teeth on large sprocket
 C = Coefficient from table

$$C = \left(\frac{z_2 - z_1}{2\pi} \right)^2$$

Example:

- $a_0 = 700$ mm $z_1 = 19$
 $p = 19,05$ mm $z_2 = 45$
 $C = 17,12$ (für $z_2 - z_1 = 26$)

$$X_0 = 2 \frac{a_0}{p} + \frac{z_1 + z_2}{2} + \frac{C \cdot p}{a_0}$$

$$X_0 = \frac{2 \times 700}{19,05} + \frac{19 + 45}{2} + \frac{17,12 \times 19,05}{700}$$

$$X_0 = 73,49 + 32 + 0,466 = 105,956$$

$$\underline{X = 106 \text{ links}}$$

With the same number of teeth $z_1 = z_2$ the chain length is:

$$X_0 = 2 \frac{a_0}{p} + z$$

With different numbers of teeth z_1 and z_2 the chain length is:

$$X_0 = 2 \frac{a_0}{p} + \frac{z_1 + z_2}{2} + \frac{C \cdot p}{a_0}$$

The calculated number of links must always be rounded up. In case of minor differences, one pitch should be added in order to avoid assembly difficulties. If the calculation results in an uneven number of chain links, one single cranked link (0,8 of breaking load) has to be mounted. In such cases it is recommended to select the next even number of links. Then the exact shaft distance can easily be calculated according to the detailed information on page 124.

$$\text{Values für "C"} = \left(\frac{z_2 - z_1}{2\pi} \right)^2$$

$z_2 - z_1$	C	$z_2 - z_1$	C	$z_2 - z_1$	C	$z_2 - z_1$	C
1	0,025	41	42,58	81	166,19	121	370,86
2	0,101	42	44,68	82	170,32	122	377,02
3	0,228	43	46,84	83	174,50	123	383,22
4	0,405	44	49,04	84	178,73	124	389,48
5	0,633	45	51,29	85	183,01	125	395,79
6	0,912	46	53,60	86	187,34	126	402,14
7	1,240	47	55,95	87	191,73	127	408,55
8	1,620	48	58,36	88	196,16	128	415,01
9	2,050	49	60,82	89	200,64	129	421,52
10	2,530	50	63,33	90	205,18	130	428,08
11	3,070	51	65,88	91	209,76	131	434,69
12	3,650	52	68,49	92	214,40	132	441,36
13	4,280	53	71,15	93	219,08	133	448,07
14	4,960	54	73,86	94	223,82	134	454,83
15	5,700	55	76,62	95	228,61	135	461,64
16	6,480	56	79,44	96	233,44	136	468,51
17	7,320	57	82,30	97	238,33	137	475,42
18	8,210	58	85,21	98	243,27	138	482,39
19	9,140	59	88,17	99	248,26	139	489,41
20	10,130	60	91,19	100	253,30	140	496,47
21	11,170	61	94,25	101	258,39	141	503,59
22	12,260	62	97,37	102	263,54	142	510,76
23	13,400	63	100,54	103	268,73	143	517,98
24	14,590	64	103,75	104	273,97	144	525,25
25	15,830	65	107,02	105	279,27	145	532,57
26	17,120	66	110,34	106	284,61	146	539,94
27	18,470	67	113,71	107	290,01	147	547,36
28	19,860	68	117,13	108	295,45	148	554,83
29	21,800	69	120,60	109	300,95	149	562,36
30	22,800	70	124,12	110	306,50	150	569,93
31	24,340	71	127,69	111	312,09	151	577,56
32	25,940	72	131,31	112	317,74	152	585,23
33	27,580	73	134,99	113	323,44	153	592,96
34	29,280	74	138,71	114	329,19	154	600,73
35	31,030	75	142,48	115	334,99	155	608,56
36	32,830	76	146,31	116	340,84	156	616,44
37	34,680	77	150,18	117	346,75	157	624,37
38	36,580	78	154,11	118	352,70	158	632,35
39	38,530	79	158,09	119	358,70	159	640,38
40	40,530	80	162,11	120	364,76	160	648,46

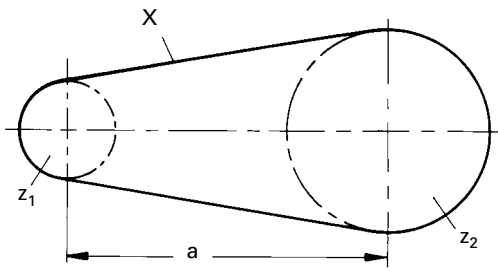

- a = Shaft distance in mm
- X = Chain length in links
- p = Pitch in mm
- z₁ = Number of teeth on small sprocket
- z₂ = Number of teeth on large sprocket

The calculation of a chain length rarely results in an even number of links. Mostly, the result must be rounded up. In order to avoid a cranked link in the chain, an even number should be selected.

The exact shaft difference is calculated according to the following formulas:

With the same number of teeth z₁ = z₂ = z the shaft distance is:

$$a = \frac{X-z}{2} p$$

With an uneven number of teeth z₁ and z₂ the shaft distance is:

$$a = p [2 X - (z_1 + z_2)] B$$

The coefficient "B" is a function of $K = \frac{X-z_1}{z_2-z_1}$ and can be taken from the following table.

Example:

$$X = 106 \text{ links} \quad z_1 = 19$$

$$p = 19,05 \text{ mm} \quad z_2 = 45$$

$$a = p [2 x - (z_1 + z_2)] B$$

$$k = \frac{X - z_1}{z_2 - z_1} = \frac{106 - 19}{45 - 19} = \frac{87}{26} = 3,34615$$

The table shows a value B = 0,24825 for K = 3,2
and a value B = 0,24849 for K = 3,4

B must be calculated by means of interpolation.

The following applies:

$$\frac{\text{Difference K times table difference B}}{\text{Table difference K}}$$

$$B = 0,24825 + \frac{(3,34615 - 3,2) \times (0,24849 - 0,24825)}{3,4 - 3,2}$$

$$B = 0,24825 + \frac{0,14615 \times 0,00024}{0,2}$$

$$B = 0,24825 + 0,00017538 = 0,24843 \text{ (rounded up)}$$

The exact shaft distance is

$$a = 19,05 (2 \times 106 - 19 - 45) 0,24843$$

$$\underline{a = 700,4 \text{ mm}}$$

Coefficient "B"

K	B	K	B	K	B	K	B
13,0	0,24 991	2,70	0,24 735	1,54	0,23 758	1,26	0,22 520
12,0	990	2,60	708	1,52	705	1,25	443
11,0	988	2,50	678	1,50	648	1,24	361
10,0	986	2,40	643	1,48	588	1,23	275
9,0	983	2,30	602	1,46	524	1,22	185
8,0	978	2,20	552	1,44	455	1,21	090
7,0	970	2,10	493	1,42	381	1,20	0,21 990
6,0	958	2,00	421	1,40	301	1,19	884
5,0	937	1,95	380	1,39	259	1,18	771
4,8	931	1,90	333	1,38	215	1,17	652
4,6	925	1,85	281	1,37	170	1,16	526
4,4	917	1,80	222	1,36	123	1,15	390
4,2	907	1,75	156	1,35	073	1,14	245
4,0	896	1,70	081	1,34	022	1,13	090
3,8	883	1,68	048	1,33	0,22 968	1,12	0,20 923
3,6	868	1,66	013	1,32	912	1,11	744
3,4	849	1,64	0,23 977	1,31	854	1,10	549
3,2	825	1,62	938	1,30	793	1,09	336
3,0	795	1,60	897	1,29	729	1,08	104
2,9	778	1,58	854	1,28	662	1,07	0,19 848
2,8	758	1,56	807	1,27	593	1,06	564

K > 13 B = 0,25

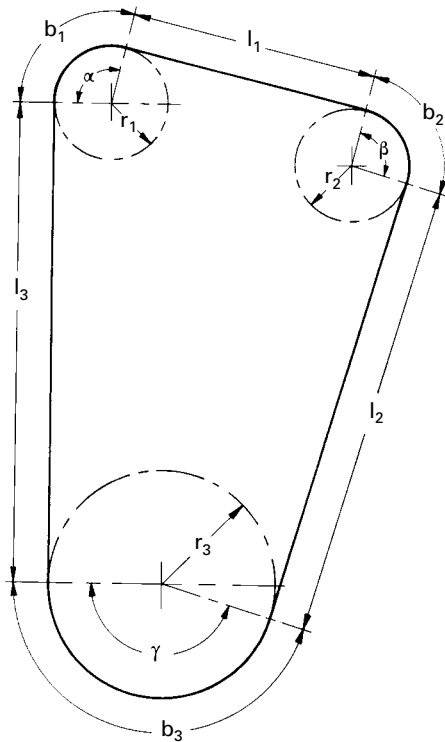

- L = Chain length in mm
- X = Chain length in links
- p = Pitch in mm
- $l_{1,2,3}$ = Tangent lengths in mm
- $r_{1,2,3}$ = Pitch circle radii in mm
- α, β, γ = Central angles in degrees
- $b_{1,2,3}$ = Arc lengths in mm
= $r_1 \text{ arc } \alpha, r_2 \text{ arc } \beta, r_3 \text{ arc } \gamma$

Example:

(see above drawing)

Chain pitch $p = 15,875 \text{ mm}$

- $r_1 = 43,2 \text{ mm} \quad \alpha = 104^\circ \quad l_1 = 188 \text{ mm}$
- $r_2 = 43,2 \text{ mm} \quad \beta = 93^\circ \quad l_2 = 345 \text{ mm}$
- $r_3 = 86,0 \text{ mm} \quad \gamma = 163^\circ \quad l_3 = 363 \text{ mm}$

- $b_1 = r_1 \text{ arc } \alpha = 43,2 \times 1,8151 = 78,41 \text{ mm}$
- $b_2 = r_2 \text{ arc } \beta = 43,2 \times 1,6232 = 70,12 \text{ mm}$
- $b_3 = r_3 \text{ arc } \gamma = 86,0 \times 2,8449 = 244,66 \text{ mm}$

$$L = b_1 + b_2 + b_3 + l_1 + l_2 + l_3$$

$$= 78,41 + 70,12 + 244,66 + 188 + 345 + 363$$

$$= 1289,19 \text{ mm}$$

$$X = \frac{L}{p} = \frac{1,289,19}{15,875} = 81,21 = \underline{\underline{82 \text{ links}}}$$

If a chain runs on several sprockets (as shown in the drawing), graphics will usually suffice to determine the chain length since this method is sufficiently accurate and considerably simpler than mathematical calculations. To begin with, the drive is drawn schematically, if possible on a scale of 1:1 or larger. Then tangents are drawn to the pitch circles, and the central angles of the circular arc spanned by the chain are determined.

For the respective arc values please refer to the table "arc lengths".

The chain length L can then be calculated by adding up the partial lengths.

$$L = l_1 + l_2 + l_3 + \dots + b_1 + b_2 + b_3 \dots$$

$$X = L/p$$

The result must always be rounded up, if possible to the next even number of links. Uneven numbers should be avoided!

Arc lengths for the radius $r = 1$

Central angle φ°	Arc length arc φ	Central angle φ°	Arc length arc φ	Central angle φ°	Arc length arc φ	Central angle φ°	Arc length arc φ
1	0,0175	46	0,8029	91	1,5882	136	2,3736
2	0,0349	47	0,8203	92	1,6057	137	2,3911
3	0,0524	48	0,8378	93	1,6232	138	2,4086
4	0,0698	49	0,8552	94	1,6406	139	2,4260
5	0,0873	50	0,8727	95	1,6580	140	2,4435
6	0,1047	51	0,8901	96	1,6755	141	2,4609
7	0,1222	52	0,9076	97	1,6930	142	2,4784
8	0,1396	53	0,9250	98	1,7104	143	2,4958
9	0,1571	54	0,9425	99	1,7279	144	2,5133
10	0,1745	55	0,9599	100	1,7453	145	2,5307
11	0,1920	56	0,9774	101	1,7628	146	2,5482
12	0,2094	57	0,9948	102	1,7802	147	2,5656
13	0,2269	58	1,0123	103	1,7977	148	2,5831
14	0,2443	59	1,0297	104	1,8151	149	2,6005
15	0,2618	60	1,0472	105	1,8326	150	2,6180
16	0,2793	61	1,0647	106	1,8500	151	2,6354
17	0,2967	62	1,0821	107	1,8675	152	2,6529
18	0,3142	63	1,0996	108	1,8850	153	2,6704
19	0,3316	64	1,1170	109	1,9024	154	2,6878
20	0,3491	65	1,1345	110	1,9199	155	2,7053
21	0,3665	66	1,1519	111	1,9373	156	2,7227
22	0,3840	67	1,1694	112	1,9548	157	2,7402
23	0,4014	68	1,1868	113	1,9722	158	2,7576
24	0,4189	69	1,2043	114	1,9897	159	2,7751
25	0,4363	70	1,2217	115	2,0071	160	2,7925
26	0,4538	71	1,2392	116	2,0246	161	2,8100
27	0,4712	72	1,2566	117	2,0420	162	2,8274
28	0,4887	73	1,2741	118	2,0595	163	2,8449
29	0,5061	74	1,2915	119	2,0769	164	2,8623
30	0,5236	75	1,3090	120	2,0944	165	2,8798
31	0,5411	76	1,3265	121	2,1118	166	2,8972
32	0,5585	77	1,3439	122	2,1293	167	2,9147
33	0,5760	78	1,3614	123	2,1468	168	2,9322
34	0,5934	79	1,3788	124	2,1642	169	2,9496
35	0,6109	80	1,3963	125	2,1817	170	2,9671
36	0,6283	81	1,4137	126	2,1991	171	2,9845
37	0,6458	82	1,4312	127	2,2166	172	3,0020
38	0,6632	83	1,4486	128	2,2340	173	3,0194
39	0,6807	84	1,4661	129	2,2515	174	3,0369
40	0,6981	85	1,4835	130	2,2689	175	3,0543
41	0,7156	86	1,5010	131	2,2864	176	3,0718
42	0,7330	87	1,5184	132	2,3038	177	3,0892
43	0,7505	88	1,5359	133	2,3213	178	3,1067
44	0,7679	89	1,5533	134	2,3387	179	3,1241
45	0,7854	90	1,5708	135	2,3562	180	3,1416

1. Given are:

(Refer to the drawing in example 1, which illustrates this worked example)

Input power	$P = 0,16 \text{ kW}$
Input speed	$n_1 = 36 \text{ min}^{-1}$
Output speed	$n_2 = 10,75 \text{ min}^{-1}$
Transmission ratio	$i = \frac{n_1}{n_2} = 3,35$
Mode of drive	electric gear motor
Driven machine	Conveyor (with uneven charging)
Approx. shaft centre distance	$a_0 \approx 530 \text{ mm}$

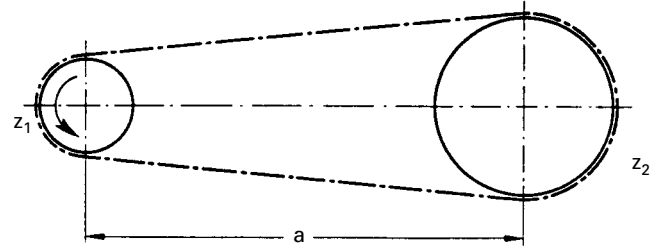

2. Selection of sprockets

Selected number of teeth on drive sprocket: $z_1 = 17$

Number of teeth on driven sprocket: $z_2 = i \cdot z_1$; $z_2 = 3,35 \cdot 17 = 57$

3. Calculations and selection of chain

3.1 Correction of chain

Correction factor for operating conditions:

$$k = f_y \cdot f_i \cdot f_z \quad (f_y = 1,4; f_i = 1; f_z = 1,13)$$

Correction factor for number of teeth:

$$k = 1,4 \cdot 1 \cdot 1,13$$

Corrected power:

$$P_C = P \cdot k$$

$$P_C = 0,16 \text{ kW} \cdot 2,17$$

$$P_C = 0,35 \text{ kW}$$

3.2 Selection of chain

For $P_C = 0,35 \text{ kW}$ and $n_1 = 36 \text{ rpm}$ the roller chain 10A-1 or 10B-1 is selected from the power diagrams (see pages 117-119)

The chain pitch p for a chain 10A-1 or 10B-1 is 15,875 mm (according to ISO 606).

3.3 Chain length

Calculation of number of links

$$X_0 = 2 \frac{a_0}{p} + \frac{z_1 + z_2}{2} + \frac{C \cdot p}{a_0}$$

Here $C = 40,529$ for $z_2 - z_1 = 57 - 17 = 40$

Result:

$$X_0 = \frac{530}{15,875} + \frac{17 + 57}{2} + \frac{40,529 \cdot 15,875}{530}$$

$$X_0 = 104,99$$

Selected number of links $X = 106$ (i.e. the next higher even number).

3.4 Chain speed

$$v = \frac{n \cdot z \cdot p}{60\,000} = \frac{36 \cdot 17 \cdot 15,875}{60\,000} = 0,16 \text{ m/s}$$

4. Maximum shaft centre distance of sprockets

Maximum shaft centre distance:

$$a = p [2X - (z_1 + z_2)] B$$

$$\text{Results } B = 0,24567 \text{ f\u00fcr } \frac{X - z_1}{z_2 - z_1} = \frac{106 - 17}{57 - 17} = 2,23 \text{ (interpolated)}$$

This is the value for the shaft centre distance:

$$a = 15,875 [2 \cdot 106 - (17 + 57)] \cdot 0,24567$$

$$a = 538,2 \text{ mm}$$

5. Lubrication

For $v = 0,16 \text{ m/s}$ and for a chain type 10A-1 or 10B-1 the diagram (page 109) shows the lubrication range I. Consequently, the simplest lubrication method, i.e. regular manual oil lubrication, will be sufficient in this case.

General information

Slack span of the return strand for horizontal drives approx. 1 % to 2 % of the shaft distance.

Chain contact angle on the drive sprocket 120° if possible (always the case when $a > d_{o2} - d_{o1}$)

at least 90° for higher number of teeth ($z \geq 25$).

The shaft distance is normally 30 times p - 50 times p .

$$\text{minimal } a_{\min} > \frac{dk_1 + dk_2}{2}$$

With longer shaft distances, heavy drives or vertical shafts, the chain weight of the pull strand and the return strand must be supported by means of chain support wheels, support rollers or guide strips. The number of teeth on the drive sprocket should be 19 if possible. The minimum number of teeth on a sprocket is 6 ($d_o = 2 p$), which is then only suitable for manual operation because of the polygon effect!

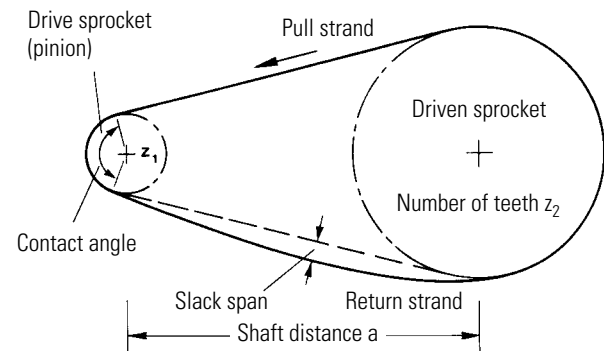

Chain drive configurations (assessment)

Favourable

In order to guarantee trouble-free operation and a long wear life, the correct chain run for the different drive configurations has to be selected. A horizontal drive or a configuration with a drive inclined by up to 60° is common and favourable. In this case the pull strand should be at the top and the return strand at the bottom.

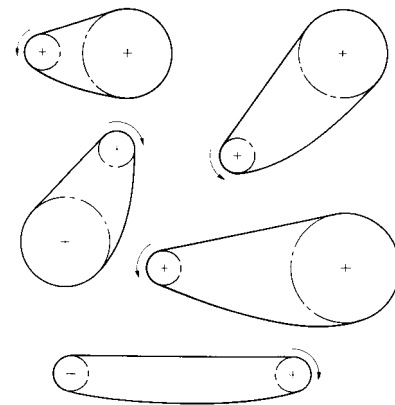

Less favourable

With horizontal drives and normal shaft distances the return strand may also be at the top.

Vertical drives should have the smaller sprocket at the top. The chain must be kept rather tight to stop it from getting slack and jumping off the lower sprocket. A minor deviation from the vertical position will improve the running conditions. It might be necessary to mount a jockey sprocket.

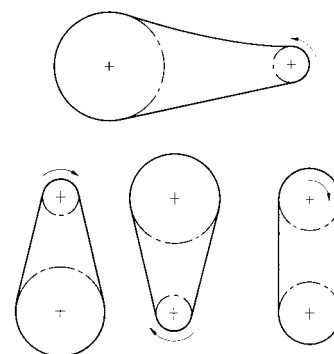

Please avoid if possible

In case of short or long shaft distances the pull strand should be at the top if possible!

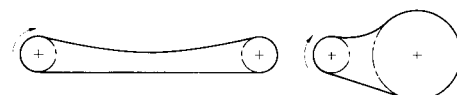



Jockey sprockets should have approximately three teeth in mesh with the return strand of the chain. On the basis of the selected number of teeth, the maximum speed (see page 119 "ratio between n and p") must not be exceeded.

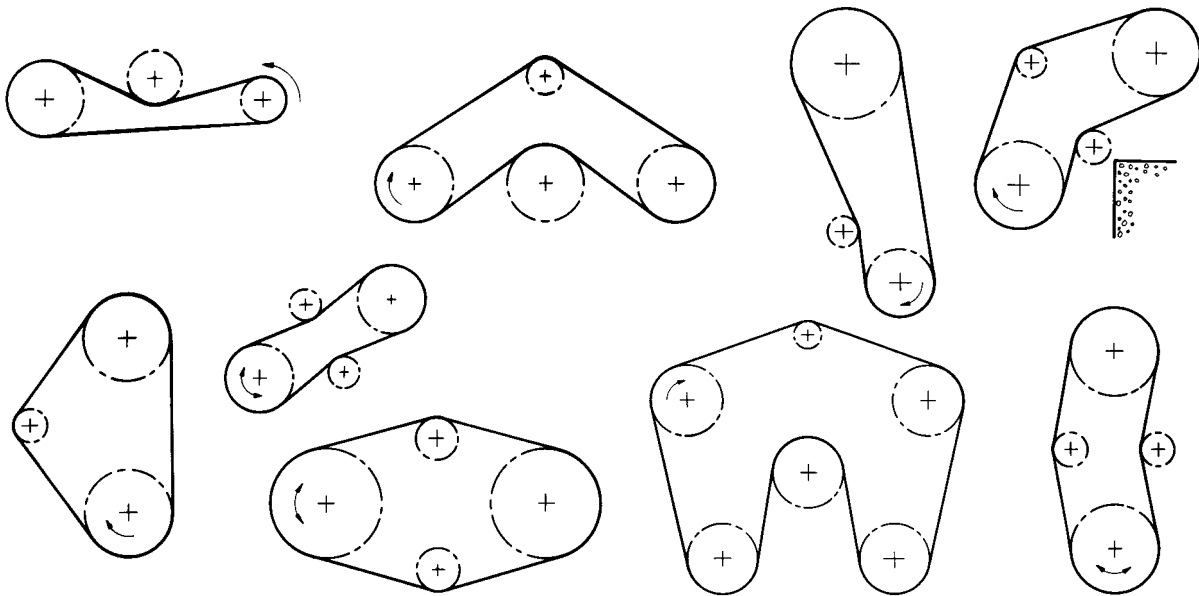

Instead of jockey sprockets, support wheels or deflexion pulleys, plastic guide rails might be advantageous in some cases to support or deflect a chain.

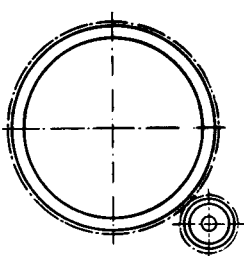

a) as outer sprocket

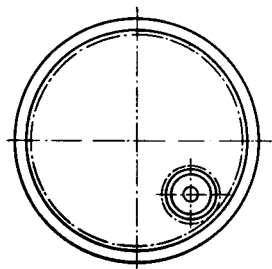

b) as inner sprocket

Roller chain instead of a sprocket for large wheel bodies, drums, revolving platforms etc.

Driving of roller conveyors

- a) by means of alternate individual chain strands driving from roller to roller
- b) by means of a circulating chain with lantern gear toothing sprockets (p.88)

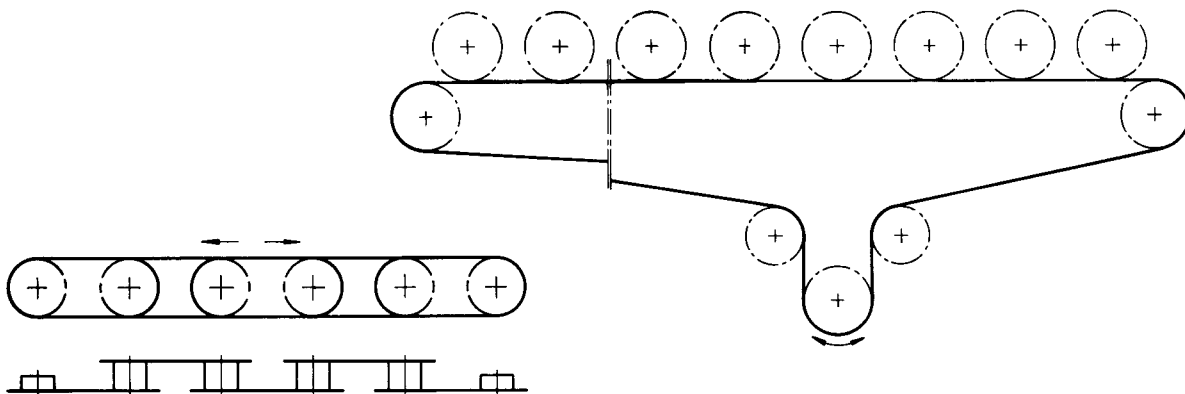

General information

A chain drive needs relatively little maintenance, if the correct chain was selected, if it was installed correctly and if it is lubricated according to the recommended procedure.

However, the chain should be protected against dirt and adverse environmental influences. A chain protection box helps to prevent dirt, averts accidents and absorbs noise.

In case of protected drives maintenance comprises a regular (annual) cleaning of the oil container and a renewal of the oil filling.

Open running chain drives must be cleaned every 3 to 6 months.

Shorter periods may be necessary, if the chains are very dirty. When cleaning the chain drives, wheel alignment and chain tension should be checked as well.

Cleaning

First of all, in order to clean a chain drive properly, the external rough dirt must be removed by means of a hard or steel brush. Subsequently, the chain is rinsed in cleaning solvent, paraffin or diesel oil.

Furthermore, it is important to clean the inner parts of the chain. Therefore the chain is placed into paraffin, diesel oil or another solvent for approximately 24 hours in order to soak the dirt in the joints as well as the hardened lubrication remnants.

If the chain is moved several times back and forth in the solvent bath, joints will be thoroughly cleaned.

After the chain has been properly cleaned it should not make anymore scratching noises when the links are moved; if it does, the remaining dirt in the joints will form a grinding compound with the lubricating agent, which would destroy the chain very quickly.

Repair

Subsequently the chain should be carefully examined for defective links, which must be replaced, if necessary.

A damaged outer link is replaced with a connecting link. Outer links are riveted into endless chains.



If an inner link or a roller is broken, the two adjoining links must also be removed; they must then be replaced by an inner link with two connecting links.

With endless chains outer links are to be used. However, if a chain looks really worn, it should be replaced by a new one.

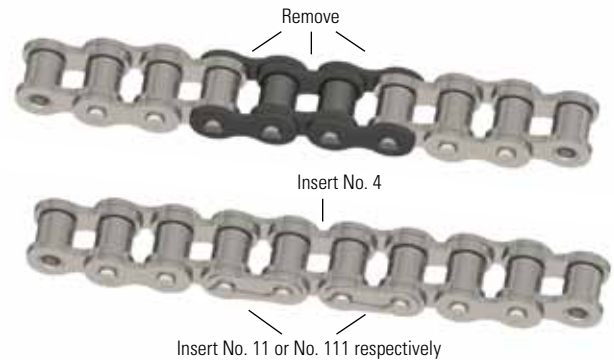

Relubrication

Thorough relubrication is to be carried out immediately after cleaning and, if necessary, repair of the chain. It is important to ensure that quality and viscosity of the lubricant comply with the operating conditions of the chain drive, e.g. temperature and velocity (please refer to pages 105 ff. It is not recommended to add just a few drops from the oil can or simply douse the chain, since the oil will not reach the chain links, i.e. those parts which actually have to be lubricated. Even if the inner and outer plates are oiled, this will by no means guarantee a proper lubrication of the inner parts such as pins and bushings.

For perfect lubrication the chain is placed into a container with liquidised special chain lubricant heated up to 120° C. The chain is left in the lubricant bath until it has reached its temperature, before it is then taken out. Excess lubricant must be allowed to drip off since it will not aid the lubrication of the chains links if it sticks to the outer plates.

However, in practice, such perfect lubrication will rarely be possible. In this case an excellent engine lubricating oil should be used according to the recommendations on page 106. Please ensure that the lubricant will actually reach the links, which are to be lubricated.

Sprockets

The sprocket teeth must be thoroughly cleaned before the chain is finally put back on. It is particularly important to remove dirt sediments, which would stretch the chain, from the

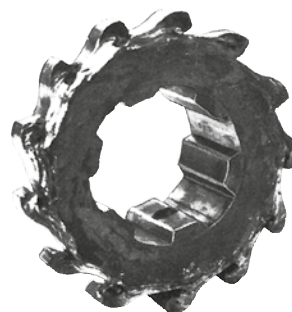

bottom of the tooth gaps. Subsequently, the sprocket must be examined in order to determine, if the teeth are worn too much. In case of excessive wear or hooked-shaped teeth, sprockets should be replaced with new ones.

It is not recommended to simply turn a worn sprocket around so that it works in reverse running direction. New sprockets are to be checked according to the specifications on page 92.

Please note that a new chain should never be placed around a worn sprocket, because this will definitely reduce the lifecycle of the chain.



Shortening by 1 link

a) Even number of links
up to a pitch of 19,05 mm



Pitch as of 25,4 mm



b) Odd number of links
up to a pitch of 19,05 mm



Pitch as of 25,4 mm



Extending by 1 link

a) Even number of links
up to a pitch of 19,05 mm



Pitch as of 25,4 mm



b) Odd number of links
up to a pitch of 19,05 mm



Pitch as of 25,4 mm



Please note: When cranked links are used, roller chains may only have 80 % of the tensile strength.

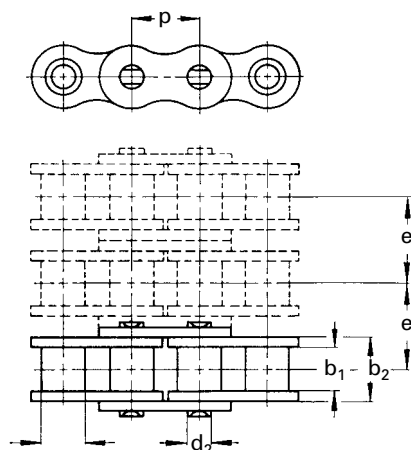

In order to avoid errors or misunderstandings please supply the following details:

Number of chains

⚙️-Chain No.

If this is unknown e.g. when ordering replacement chains, please supply a short part of the chain as a sample (at least one inner link) or, alternatively, state the following dimensions according to the adjoining drawing:

1. Pitch p
2. Inner width b_1
3. Inner link width b_2
4. Roller and bushing diameter as well as
5. Pin diameter for Galle chains d_1
6. Shoulder diameter for Galle chains d_2
7. Transverse pitch (only for multiplex roller chains)
8. Please state, if simplex, duplex or multiplex chain designs are required

For replacement chains it is sufficient to state the main dimensions p , b_1 and d_1 as well as e for multiplex chains. If a chain is to be extended or repaired, all the dimensions shown in the drawing must be supplied.

Please note: In case of replacements it is important to replace both sprockets as well as chains!

Length of chain in meters or links

- 1.) When ordered by length in metres (e.g. 5 m) the end links are always inner links. Connecting links must be ordered separately.
- 2.) When ordered by number of links:

Orders for chains with even number of links

	chain is supplied:
ready to be installed	including one connecting link
open*	end links = inner links including one single cranked link
endless	riveted

Orders for chains with odd number of links

	chain is supplied:
einbaufertig*	(up to a pitch of $p = 19,05 \text{ mm} = 3/4''$) including one double cranked link and one connecting link (up to a pitch of $p = 25,4 \text{ mm} = 1''$) including one single cranked link
open	end links = inner links
endless*	riveted (including one cranked link)

* When cranked links are used, roller chains may only have 80 % of the breaking load. Avoid if possible!

What will the chain be used for?

Please inform us on the application area of the chain. Only then will we be able to offer you the perfect chain for the application you have in mind – and you will benefit from our long-time experience!

Parallel running chains

Chains envisaged for parallel running operation are matched for length, pre-stretched and marked at extra cost.

It is important to clearly stipulate this requirement when ordering!

In special cases measured chains can be supplied at extra cost.

In order to avoid errors or misunderstandings please supply the following details:

Number of chains

⚙️-Chain No. of the basic chain

Type of attachment links

(e.g. A, B, C, D, E or F); for other special designs please state if single-sided or double sided attachments are required.

Attachment spacing T of special links

in (preferably even) multiples of pitch p

If attachments are also available on the inner link, the attachment spacing can be arranged in any way. In case of an odd number (e.g. $T = 3p$) the attachment is alternated on the outer and inner rings. If inner link attachments are not available, an odd number spacing can only be made possible by mounting a cranked connecting link No. 12 or a double cranked link No. 15. In this case the chain may only have 80 % of the breaking load!

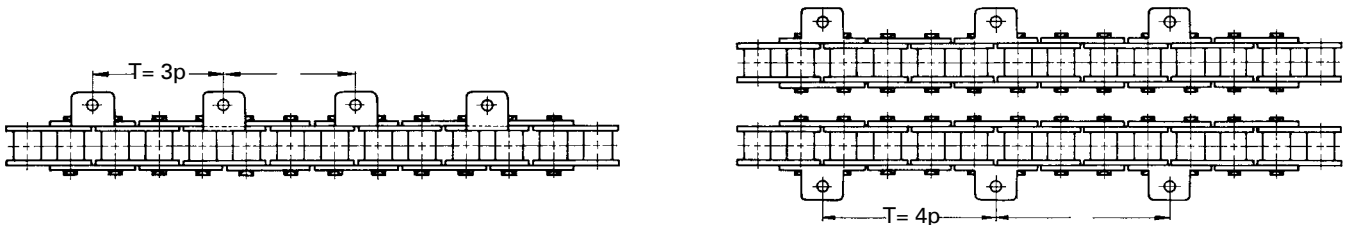

Length of chain in metres and links

- When ordered by length in metres, the end links are always inner links. Connecting links must be ordered separately!
- When ordered by a certain number of links, this number should be divisible by the distance T of the special links (e.g. chain length 176 links, $T = 4p$, i.e. every 4th link is a special link; the chain includes $176 : 4 = 44$ special links).

If the chain length cannot be a multiple of T , but has to be longer or shorter for design reasons, this fact must be clearly stated as: "Does not work out even!"

In such a case the distance T at the end of the chain will be alternately longer or shorter.

Chains with an even number of links will be delivered with a connecting link and are ready for assembly. With a distance of $T = 2p$ (each outer link is a special link) the connecting link is supplied in the respective special design. With a distance of $T = 4p$ and more the connecting link will be supplied in the standard design.

Please note: When cranked links are used, roller chains may only have 80% of the breaking load. Avoid if possible!

Matched or pre-stretched special chains

Parallel running chain strands used for transport and conveying purposes are often required to have highly matching opposite attachments. At extra cost we will supply the appropriately matched chain strands and mark them accordingly.

When ordering your chain, please state clearly: Please supply matched, pre-stretched and marked chain strands!

The installation of guide rails is recommended to help support and guide chains with long span lengths.



Questionnaire for chain drives

What is to be conveyed or driven by the chain? (If an existing chain drive is to be replaced, please state which one!)

.....

.....

Chain drive

Please underline where applicable and enter the respective data if necessary!

Power requirement (max. power to be transmitted) power output $P = \dots\dots\dots$ PS/kW torque $M = \dots\dots\dots$ Nm tensile force $F = \dots\dots\dots$ N

Drive (type and performance) $\dots\dots\dots$ / $\dots\dots\dots$ hp/kW
(e.g. electric motor, internal combustion engine / 2, 4, 6 cylinders etc.)

Chain loading operation period $\dots\dots\dots$ hours/day
 regular cyclic impact alternating direction $\dots\dots\dots$ times per hour
 interruption (re-start) approx. $\dots\dots\dots$ times per hour

Centrifugal mass for impact compensation existing possible not existing not possible

Axial distance $a = \dots\dots\dots$ mm
 shaft distance is adjustable by $\dots\dots\dots$ mm / not adjustable
 jockey sprocket clamping rail clamping spring automatic chain tensioner

Ambient influences nothing in particular dust fibres sand humidity
 temperatures up to $\dots\dots\dots$ °C corrosion caused by $\dots\dots\dots$

Chain protection box dust proof not dust proof installation not possible
 chain unprotected chain protected by engine / machine housing

Lubrication not permitted manually (occasionally) drip feed
 oil bath pressure circulation

Sprockets

	Driving sprocket	Driven sprocket
Speed	$n_1 = \dots\dots\dots$ rpm	$n_2 = \dots\dots\dots$ rpm
or		
planned transmission ratio	$i = \dots\dots\dots$	

Sprocket diameter (\varnothing) Largest possible incl. chain	max. = $\dots\dots\dots$ mm	max. = $\dots\dots\dots$ mm
Sprocket width Largest possible incl. chain	max. = $\dots\dots\dots$ mm	max. = $\dots\dots\dots$ mm
Sprocket design	$\dots\dots\dots$	$\dots\dots\dots$

Hub bore (shaft \varnothing)	$d_1 = \dots\dots\dots$ mm	$d_2 = \dots\dots\dots$ mm
Hub length	$L_1 = \dots\dots\dots$ mm	$L_2 = \dots\dots\dots$ mm
Hub design One-sided: standard Double-sided: symmetrical or asymmetrical	$\dots\dots\dots$	$\dots\dots\dots$
Installation on the shaft (groove sizes according to DIN)	$\dots\dots\dots$	$\dots\dots\dots$

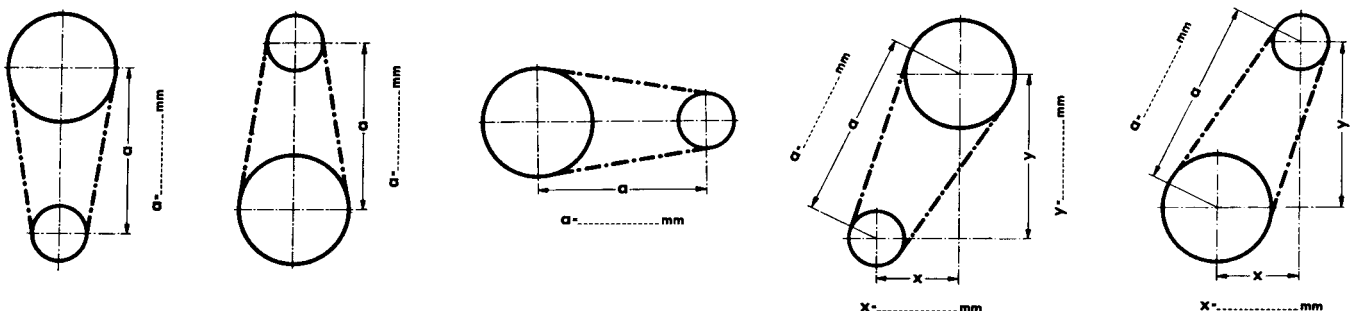

Please enter the dimensions of the requested drive into the drawing. The driving wheel designation should be T. Please indicate the rotation direction by an arrow and in case of alternating rotation direction by a double arrow (\longleftrightarrow).



Conditions/Symptoms	Possible cause	What to do
One-sided wear on chains and sprockets	1. Shafts not parallel, sprocket and pinion not aligned	1. Realign
Wear on inner plates or on sides of sprocket teeth	1. Sprocket and pinion not aligned or shaft wobble	1. Realign sprockets
Wear on tooth heads	1. Chain elongation 2. Tooth error	1. Replace chain 2. Replace pinion and sprocket
Wear on tooth flanks, sprockets	1. Low material strength	1. Exchange for hardened sprockets
Wear on outer plates	1. Chain striking an obstruction	1. Make sure chain is not obstructed
Chain vibrates with high frequency	1. Eccentricity or sprocket wobble 2. Broken chain roller	1. Replace sprockets 2. Replace chain links or chain
Premature elongation	1. Insufficient lubrication or wrong chain size	1. Increase oil supply and check chain size
Rust-coloured discolouration of chain and pins	1. Insufficient lubrication	1. Improve lubrication
Chain jumps off sprocket	1. Excess chain slack 2. Chain riding too high on sprocket teeth due to chain wear	1. Adjust shaft centre distance or jockey sprocket 2. Replace chain
Broken chain parts	1. Drive overloaded 2. Excess chain slack and chain jumps off sprocket 3. Chain striking solid object 4. Chain speed too high 5. Imprecise tothing on the sprockets 6. Insufficient lubrication 7. Corrosion	1. Select another chain or avoid overload 2. Regular check and adjustment of shaft centre distance 3. Make sure chain is not obstructed 4. Check chain dimensioning 5. Change sprockets 6. Improve and increase lubrication 7. Avoid corrosion or use chains made of stainless material (please enquire)
Excessive noise	1. Chain striking an obstruction 2. Insufficient lubrication 3. Missing or broken rollers 4. Misalignment 5. Chain jumps off sprocket	1. Make sure chain is not obstructed 2. Improve lubrication 3. Replace chain or defective parts 4. Align shafts and sprockets 5. Re-adjust shaft centre distance



ISO-designation	WIPPERMANN-designation	Design	Page
	2DH I	Top plate conveyor chain	59
3	440	Roller chain	10
4	445	"	10, 56
	D 445	"	11
04C-1	ASA 25	Bush chain	13
05B-1	450	Roller chain	10, 48, 49, 56
	450 RF	" stainless steel	42, 51
	453	"	10
	454	"	10
05B-2	D 450	Roller chain	11
	D 450 RF	" stainless steel	43
05B-3	T 450	"	12
06B-1	455 GL	"	10, 17, 36, 48-50, 56, 57
	06B -1 MA	" maintenance-free	34, 36
	455 RF	" stainless steel	42, 50, 51
	455 RFKIGL	Plastic innerlink stainless steel	42
	455 TL	Roller chain	45
06C-1	ASA 35	Bush chain	13, 56
	ASA 35 RF	Roller chain stainless steel	42
06B-2	455 GL-2	"	11, 17, 57
	455 GL-2 MA	" maintenance-free	34, 36
	06B -2 GL MA	" "	34, 36
	D 455 RF	" stainless steel	43
06B-3	T 455 RF	"	44
06C-2	ASA 35 -2	Bush chain	14
	ASA 35 -2 RF	"	43
06B-3	455 GL-3	Roller chain	12, 17
	455 GL-3 MA	" maintenance-free	34, 36
	06B -3 MA	" "	34, 36
06C-3	ASA 35 -3	Bush chain	15
08A-1	ASA 40	Roller chain	13, 48, 49, 56
	08A -1 MA	" maintenance-free	31, 56
	ASA 40 RF	" stainless steel	42, 51
	ASA 40 SB	Sidebow chain	16
	ASA 40 SB RF	" stainless steel	16
81	331	Roller chain	10, 48, 49
	331 RF	" stainless steel	42, 51
	332	"	10, 48, 49
	332 RF	" stainless steel	42, 51
82	110	"	10
83	17	"	10
	18	"	45
	460	"	45
	461	"	10
08B-1	462	"	10, 48-50, 52, 53, 56, 57
	08B -1 BI	"	25
	08B -1 BI KS	"	27
	08B -1 TR HT	" maintenance-free	29
	08B -1 TR KS	" maintenance-free	31
	08B -1 MA	Roller chain maintenance-free	34
	462 GL	"	17
	462 GL MA	" maintenance-free	36
	462 RF	" stainless steel	42, 50, 51
	462 RFKI	Plastic innerlink stainless steel	42
	462 RF GL	"	42
	462 RF MA	" maintenance-free	41
	462 GL	with POM-clip	19
	462 GL	with TPU-clip	21
	462 SB	Sidebow chain	16
08A-2	ASA 40 -2	Roller chain	14
	08A -2 MA	" maintenance-free	35
	ASA 40 -2 RF	" stainless steel	43
08B-2	D 462	"	11, 57
	08B -2 BI	"	25
	08B -2 BI KS	"	27
	08B -2 TRHT	" maintenance-free	29
	08B -2 TRKS	" maintenance-free	31
	08B -2 MA	" maintenance-free	34
	462 GL-2	"	17
	462 GL-2 MA	" maintenance-free	36

ISO-designation	WIPPERMANN-designation	Design	Page
	D 462 RF	" stainless steel	43
	D 462 RF MA	" maintenance-free	41
	D 462 GL	with POM-clip	19
	08A -3 MA	" maintenance-free	35
08B-3	T 462	"	12
	08B -3 BI	"	25
	08B -3 BI KS	"	27
	08B -3 TRHT	" maintenance-free	29
	08B -3 TRKS	" maintenance-free	31
	08B -3 MA	" maintenance-free	34
	462 GL-3	"	17
	462 GL-3 MA	" maintenance-free	36
08B-3	T 462 RF	" stainless steel	44
	T 462 RF MA	" maintenance-free	41
10A-1	ASA 50	"	13, 48, 49, 56
	ASA 50 H	" reinforced	13
	ASA 50 HX	" "	22
	10A -1 MA	" maintenance-free	35, 56
	500	"	10
10B-1	501	"	10, 48-50, 52, 53, 56, 57
	10B -1 BI	"	25
	10B -1 BI KS	"	27
	10B -1 TRHT	" maintenance-free	29
	10B -1 TRKS	" maintenance-free	31
	10B -1 MA	" maintenance-free	34, 48-53
	501 GL	"	17
	501 GL MA	" maintenance-free	36
	501 RF	" stainless steel	42, 50, 51
	501 RF GL	" "	42
	501 RF MA	" maintenance-free	41
	501 GL	with POM-clip	19
	501 SB	Sidebow chain	16
10A-2	ASA 50 -2	"	14
	10A -2 MA	" maintenance-free	35
10B-2	D 501	"	11, 57
	10B -2 BI	"	25
	10B -2 BI KS	"	27
	10B -2 TRHT	" maintenance-free	29
	10B -2 TRKS	" maintenance-free	31
	10B -2 MA	" maintenance-free	34
	501 GL-2	"	17
	501 GL-2 MA	" maintenance-free	36
	D 501 RF	" stainless steel	43
	D 501 RF MA	" maintenance-free	41
	D 501 GL	with POM-clip	19
10A-3	ASA 50 -3	"	15
	10A -3 MA	" maintenance-free	35
10B-3	T 501	"	12
	10B -3 BI	"	25
	10B -3 BI KS	"	27
	10B -3 TRHT	" maintenance-free	29
	10B -3 TRKS	" maintenance-free	31
	10B -3 MA	" maintenance-free	34
	501 GL-3	"	17
	501 GL-3 MA	" maintenance-free	36
10B-3	T 501 RF	" stainless steel	44
	T 501 RF MA	" maintenance-free	41
12A-1	ASA 60	"	13, 48, 49, 56
	12A -1 MA	" maintenance-free	35, 56
	ASA 60 GL	"	17
	ASA 60 H	" reinforced	13
	ASA 60 HX	" "	22
	ASA 60 HGL	" "	17
	ASA 60 RF	" stainless steel	42
	ASA 61 SB	Sidebow chain	16
	ASA 61 SB RF	" stainless steel	16
12B-1	513	"	10, 48 -50, 52, 53, 56, 57
	12B -1 BI	"	25
	12B -1 BI KS	"	27
	12B -1 TRHT	" maintenance-free	29



ISO-designation	WIPPERMANN-designation	Design	Page
	12B -1 TRKS	" maintenance-free	31
	12B -1 MA	" maintenance-free	34, 48-53
	513 GL	"	17
	513 GL MA	"	36
	513 GL	with POM-clip	19
	513 GL	with TPU-clip	21
	513 RF GL	" "	42
	513 RF MA	" maintenance-free	41
	513 SF RF	Accumulator chain stainless steel	60, 61
	513 SF	Accumulator chain	60, 61
	513 SF MA	" maintenance-free	38, 39
	513 SB	Side bow chains	16
12A-2	ASA 60 -2	Roller chain	14
	12A -2 MA	" maintenance-free	35
	ASA 60 GL-2	"	17
	ASA 60 -2 RF	" stainless steel	43
12B-2	D 513	"	11, 57
	12B -2 BI	"	25
	12B -2 BI KS	"	27
	12B -2 TRHT	" maintenance-free	29
	12B -2 TRKS	" maintenance-free	31
	12B -2 MA	" maintenance-free	34
	513 GL-2	"	17
	513 GL-2 MA	" maintenance-free	36
	D 513 RF	"	42
	D 513 RF MA	" maintenance-free	41
	D 513 SF	Accumulator chain	60, 61
	D 513 SF MA	" maintenance-free	38, 39
	D 513 GL	with POM-clip	19
12A-3	ASA 60 -3	Roller chain	15
	12A -3 MA	" maintenance-free	35
	ASA 60 GL-3	"	17
12B-3	T 513	"	12
	12B -3 BI	"	25
	12B -3 BI KS	"	27
	12B -3 TRHT	" maintenance-free	29
	12B -3 TRKS	" maintenance-free	31
	12B -3 MA	" maintenance-free	34
	513 GL-3	"	17
	513 GL-3 MA	" maintenance-free	36
12B-3	T 513 RF	" stainless steel	44
	T 513 RF MA	" maintenance-free	41
	T 513 SF RF	Accumulator chain stainless steel	60, 61
	T 513 SF	"	60, 61
	T 513 SF MA	" maintenance-free	38, 39
	515	Roller chain	45
	517	"	45
	540	"	45
	546 b	"	45
	547	"	45
16A-1	ASA 80	"	13, 48, 49, 56
	ASA 80 H	" reinforced	13
	ASA 80 HX	" "	22
	16A -1 MA	" maintenance-free	35, 56
16B-1	548	"	10, 48-50, 52, 53, 56, 57
	16B -1 BI	"	25
	16B -1 BI KS	"	27
	16B -1 TRHT	" maintenance-free	29
	16B -1 TRKS	" maintenance-free	31
	16B -1 MA	" maintenance-free	34, 48-53
	548 GL	"	17
	548 GL MA	" maintenance-free	36
	548 GL	with POM-clip	19
	548 GLS	"	19
	548 GLS MA	" maintenance-free	36
	548 GLS	with POM-clip	19
	548 GLS	with TPU-clip	21
	548 GLX	" reinforced	22
	548 RF	" stainless steel	42, 50, 51
	548 RF GL	" "	42

ISO-designation	WIPPERMANN-designation	Design	Page
	548 RF GLS	" "	42
	548 SF RF	Accumulator chain "	60, 61
	548 SF	"	60, 61
	548 SF MA	" maintenance-free	38, 39
	548 SB	Sidebow chain	16
16A-2	ASA 80 -2	Roller chain	14
	16A -2 MA	" maintenance-free	35
16B-2	D 548	"	11, 57
	16B -2 BI	"	25
	16B -2 BI KS	"	27
	16B -2 TRHT	" maintenance-free	29
	16B -2 TRKS	" maintenance-free	31
	16B -2 MA	Roller chain maintenance-free	30
	548 GL-2	"	17
	548 GLS-2	"	17
	548 GL-2 MA	" maintenance-free	36
	548 -2 GLX	"	22
	D 548 RF	" stainless steel	43
	D 548 RF MA	" maintenance-free	41
	D 548 SF	Accumulator chain	60, 61
	D 548 SF MA	" maintenance-free	38, 39
16A-3	ASA 80 -3	Roller chain	15
	16A -3 MA	" maintenance-free	35
16B-3	T 548	"	12
	16B -3 BI	"	25
	16B -3 BI KS	"	27
	16B -3 TRHT	" maintenance-free	29
	16B -3 TRKS	" maintenance-free	31
	16B -3 MA	Roller chain maintenance-free	34
	548 GL-3	"	17
	548 GLS-3	"	17
	548 GL-3 MA	" maintenance-free	36
	548 -3 GLX	"	22
16B-3	T 548 RF	" stainless steel	44
	T 548 RF MA	" maintenance-free	41
	T 548 SF RF	Accumulator chain stainless steel	60, 61
	T 548 SF	"	60, 61
	T 548 SF MA	" maintenance-free	38, 39
20A-1	ASA 100	Roller chain	13, 56
	ASA 100 H	" reinforced	13
	ASA 100 HX	" "	22
	20A -1 MA	" maintenance-free	35, 56
	552	"	10, 56
	552 MA	" maintenance-free	34, 56
20B-1	563	"	10, 48-50, 56
	20B -1 BI	"	25
	20B -1 BI KS	"	27
	20B -1 TRHT	" maintenance-free	29
	20B -1 TRKS	" maintenance-free	31
	20B -1 MA	" maintenance-free	34, 48-50, 56
	563 GL	"	17
	563 GL MA	" maintenance-free	36
	563 GL	with POM-clip	19
	563 GLX	" reinforced	22
20A-2	ASA 100 -2	"	14
	20A -2 MA	" maintenance-free	35
20B-2	D 563	"	11
	20B -2 BI	"	25
	20B -2 BI KS	"	27
	20B -2 TRHT	" maintenance-free	29
	20B -2 TRKS	" maintenance-free	31
	20B -2 MA	" maintenance-free	34
	563 GL-2	"	17
	563 GL-2 MA	" maintenance-free	36
	563 -2 GLX	"	22
20A-3	ASA 100 -3	"	15
	20A -3 MA	" maintenance-free	35
20B-3	T 563	"	12
	20B -3 BI	"	25
	20B -3 BI KS	"	27



ISO-designation	WIPPERMANN-designation	Design	Page
	20B-3 TRHT	" maintenance-free	29
	20B-3 TRKS	" maintenance-free	31
	20B-3 MA	" maintenance-free	30
	563 GL-3	"	17
	563 GL-3 MA	" maintenance-free	36
	563-3 GLX	"	22
	577	"	45,56
24A-1	ASA 120	"	13, 56
	ASA 120 H	" reinforced	13
	ASA 120 HX	"	22
	24A-1 MA	" maintenance-free	35, 56
24B-1	596	"	10, 48-50, 56
	24B-1 BI	"	25
	24B-1 BI KS	"	27
	24B-1 TRHT	" maintenance-free	29
	24B-1 TRKS	" maintenance-free	31
	24B-1 MA	" maintenance-free	34, 48-53
	596 GL	"	17
	596 GL MA	" maintenance-free	36
	596 R	"	22
	596 SX	"	22
24A-2	ASA 120-2	"	14
	24A-2 MA	" maintenance-free	35
24B-2	D 596	"	11
	24B-2 BI	"	25
	24B-2 BI KS	"	27
	24B-2 TRHT	" maintenance-free	29
	24B-2 TRKS	" maintenance-free	31
	24B-2 MA	" maintenance-free	34
	596 GL-2	"	17
	596 GL-2 MA	" maintenance-free	36
24A-3	ASA 120-3	"	15
	24A-3 MA	" maintenance-free	35
24B-3	T 596	"	12
	24B-3 BI	"	25
	24B-3 BI KS	"	27
	24B-3 TRHT	" maintenance-free	29
	24B-3 TRKS	" maintenance-free	31
	24B-3 MA	Roller chain maintenance-free	34
	596 GL-3	Roller chain	17
	596 GL-3 MA	" maintenance-free	36
28A-1	ASA 140	"	13
	ASA 140 H	" reinforced	13
	ASA 140 HX	"	22
28B-1	613	"	10, 48, 49, 56
28A-2	ASA 140-2	"	14
28B-2	D 613	"	11
28A-3	ASA 140-3	"	15
28B-3	T 613	"	12
32A-1	ASA 160	"	13
	ASA 160 H	" reinforced	13
	ASA 160 HX	"	22
32B-1	652	"	10, 48, 49, 56
32A-2	ASA 160-2	"	14
32B-2	D 652	"	11
32A-3	ASA 160-3	"	15
32B-3	T 652	"	12
40A-1	ASA 200	"	13
	ASA 200 H	" reinforced	13
	ASA 200 HX	"	23
40B-1	671	"	10
	671 SX	"	22
40A-2	ASA 200-2	"	14
40B-2	D 671	"	11
40A-3	ASA 200-3	"	15
40B-3	T 671	"	12
48B-1	679	"	10
48B-2	D 679	"	11
48B-3	T 679	"	12
208 B	713	"	37, 54, 55

ISO-designation	WIPPERMANN-designation	Design	Page
	208 B MA	" maintenance-free	37, 54, 55
208 B	713 RF	" stainless steel	46, 54, 55
210 B	717	Roller chain	46, 54, 55
	210 B MA	" maintenance-free	37, 54, 55
210 B	717 RF	" stainless steel	37, 54, 55
212 B	722	"	37, 54, 55
	212 B MA	" maintenance-free	37, 54, 55
212 B	722 RF	" stainless steel	37, 54, 55
	722 SF RF	Accumulator chain	60,61
	722 SF	"	60,61
	722 SF MA	" maintenance-free	38, 39
216 B	728	Roller chain	46, 54, 55
	216 B MA	Roller chain maintenance-free	37, 54, 55
216 B	728 RF	" stainless steel	46, 54, 55
	728 SF RF	Accumulator chain	60,61
	728 SF	"	60,61
	728 SF MA	" maintenance-free	38, 39
220 B	734	Roller chain	46, 54, 55
	220 B MA	" maintenance-free	37, 54, 55
	6144	Roller chain agricultural	45
	1105	Hollow pin chain	23
	1462	"	23
	1463	"	23
	1500	"	23
	1501	"	23
	1513	"	23
	1589	"	23
	1598	"	23
	1650	"	23
	1650 RF	" stainless steel	23
	320	ATC chain	64-67
	340	ATC chain	64-67
	1110	Inverted tooth chain with bushings	72
	1112	"	72
	1114	"	72
	1115	"	72
	06-015/20A	Inverted tooth chain	73
	06-025/030/035J	"	73
	08-015/020A	"	73
	08-025/030/035J	"	73
	08-050/65J	"	73
	10-025/035/040J	"	73
	10-050/065J	"	73
	12-035/040/050J	"	73
	12-065/075J	"	73
	16-050/065/075J	"	73
	16-100/125J	"	73
	24-065/075/100J	"	73
	24-125/150J	"	73
	32-100/115/135J	"	73
	32-150/180J	"	73
	HD06-015/020A	Inverted tooth chain type serie HD	74
	HD06-025/030/040J	"	74
	HD06-050/065J	"	74
	HD08-015/020A	"	74
	HD08-025/030/040J	"	74
	HD08-050/065/075J	"	74
	HD08-100J	"	74
	HD12-030A	"	74
	HD12-035/040J	"	74
	HD12-050/065/085J	"	74
	HD12-100/125/150J	"	74
	HD12-200J	"	74
	HD16-040/050/065J	"	74
	HD16-075/100/125J	"	74
	HD16-150/200J	"	74
	HP06-015/020A	Inverted tooth chain type serie HP	75
	HP06-025/030/040J	"	75
	HP06-050/065J	"	75
	HP08-015/025A	"	75



1	WIPPERMANN jr. GmbH Direkt	Service-Stützpunkt Im Obrock 153 D-32278 Kirchlengern	Phone: +49 5223763330 Fax: +49 5223763338 E-mail: direkt@wippermann.com	
2	Donald Mertner	Industriervertretungen Johannesweg 17 b D-33397 Rietberg	Phone: +49 52449069809 Fax: +49 52449069810 Mobile: +49 1716203193 E-mail: donald.mertner@freenet.de	
3	ATS Antriebstechnik	Dipl. Ing. (FH) Helmar Sperl Schaddeler Dreieck Nr. 40 D-04668 Grimma OT Großbothen	Phone: +49 3438473341 Fax: +49 3438473342 Mobile: +49 1729444640 E-mail: ats-sperl@t-online.de	
4	hohmann GmbH	Industriervertretungen Hertichstr. 70 D-71229 Leonberg	Postfach 1765 71207 Leonberg	Phone: +49 7152331130 Fax: +49 71523311310 E-mail: info@hohmann-iv.de
5	Regionalvertretung Bayern	Thomas Roth Am Schweizerbild 11 D-88630 Pfullendorf	Phone: +49 75529281327 Fax: +49 75529281331 Mobile: +49 1732593115 E-mail: thomas.roth@wippermann.com	
6	Regionalvertretung West	Carsten Lilge Am Sassendorfer Wege 5 D-59505 Bad Sassendorf	Phone: +49 29213 69 09 85 Fax: +49 29219619230 Mobile: +49 1734179270 E-mail: carsten.lilge@wippermann.com	
7	Regionalvertretung Nord	Klaus Marquardt Lange Straße 30 D-27211 Bassum	Phone: +49 42418209063 Fax: +49 424182 09 942 Mobile: +49 1733035660 E-mail: klaus.marquardt@wippermann.com	



Austria	KATENA Stahlgelenketten Handelsges. m.b.H Jedlersdorfer Platz 7 A-1210 Wien	Phone: +43 12921071 Fax: +43 12929762 E-mail: office@katena.at Internet: www.katena.at
Czech Republic	BMC-TECH Hviezdoslavova CZ-627 00, Brno	Phone: +420 545226047 Fax: +420 545226048 E-mail: info@bmc-tech.cz Internet: www.bmc-tech.cz
Finland	SKS Mekaniikka Oy PL 122 FIN-01721 Vantaa	Phone: +358 2076461 Fax: +358 207646824 E-mail: mekaniikka@sk.fi Internet: www.sk.fi
France	Prud'homme Transmissions 25, Chemin d'Aubervilliers F-93203 Saint-Denis Cedex	Phone: +33 148114600 Fax: +33 148344949 E-mail: info@prudhomme-trans.com Internet: www.prudhomme-trans.com
Great Britain	Transmission Developments Co (G.B.) Ltd. Dawkins Road, Hamworthy, Poole GB-Dorset BH15 4HF	Phone: +44 1202675555 Fax: +44 1202677466 E-mail: sales@transdev.co.uk Internet: www.transdev.co.uk
Greece	MAS Michael Sofikitis & Son S.A. 295 Monastiriou str. GR-54628 Thessaloniki	Phone: +30 2310553443 Fax: +30 2310551439 E-mail: sofikitis@the.forthnet.gr
Italy	Kuhn W. S.r.l. Via E. Mattei 84/13 I-40138 Bologna	Phone: +39 51531584 Fax: +39 51531611 E-mail: info@kuhnw.it Internet: www.kuhnw.it
Latvia	SIA Iuna Gultni Kurzemes prospekts 164A LV-1067 Riga	Phone: +371 25999999 Fax: +371 67808009 Internet: www.iuna.lv
Lithuania	UAB „Dagmita“ Raudondvario pl. 162a LT-47174 Kaunas	Phone: +370 837363487 Fax: +370 837362260 E-mail: dagmita@dagmita.lt Internet: www.dagmita.lt
The Netherlands	K&W Transmissies B.V. Poseidonweg 31 NL-8239 DK Lelystad	Phone: +31 320247370 Fax: +31 320246594 E-mail: info@wippermann.nl Internet: www.kwtransmissies.nl
Norway	Jens S. Transmisjoner AS P.O. box 9, Manglerud N-0612 Oslo	Phone: +45 70138333 Fax: +45 43731911 E-mail: info@jens-s.dk Internet: www.jens-s.dk
Russia	Company Progress Ltd Melnichnaya str., 18A p/o 34 RUS-192019 Saint-Petersburg	Phone: +7 8126220888 Fax: +7 8126220888 E-mail: companyttcprogress@gmail.com Internet: www.ttcprogress.ru
Slovenia Serbia, Croatia Bosnia/Herzegovina Montenegro/Macedonia	BELL d.o.o. Ptujaska Cesta 13 SI-2204 Miklavz na Dravskem polju	Phone: +386 26296920 Fax: +386 26292120 E-mail: info@bell.si Internet: www.bell.si



Spain	Comercio Industria y Distribución, S.L Poligono CTM Nave S8 - Local 9 E-28053 Madrid	Phone: +34 915072838 Fax: +34 915072773 E-mail: cid@cid.es Internet: www.cid.es
	Delegacion Norte Kaukarreka Bidea, 3 P.109 (Pol.Asua-Berri) E-48950 Erandio (Bizkaia)	Phone: +34 914536029 Fax: +34 914535762
	Suministros Y Cadenas Pol. Ind. Sur - c/ Industria 43 E-08754 El Papiol (Barcelona)	Phone: +34 936730867 Fax: +34 936730861
Sweden	Ingenjörfirman Kedjeteknik AB Baragatan 2 SE-21228 Malmö	Phone: +46 40181000 Fax: +46 40932332 E-mail: info@kedjeteknik.se Internet: www.kedjeteknik.se
Switzerland	C. Plüss & Co. AG Oberdorfstr. 64 CH-8600 Dübendorf	Phone: +41 448248800 Fax: +41 448248818 E-mail: service@pluss.com Internet: www.pluss.com
Turkey	EKINIS TARIM MAKAINALARI TIC ve SAN A.S. Tünel Caddesi Perçemli Sok., No. 4/1-2-3 Karaköy TR-34420 Istanbul	Phone: +90 2122521920 Fax: +90 2122441134 E-mail: ekinis@ekinis.com Internet: www.ekinis.com

A

Accumulator chains - MARATHON	38,39
Accumulator chains	60-62
Acid-resistant chains RF (stainless steel)	41-44,50,51,53,54,56-58,60,61
Advantages of roller chain drives	114
AFS-Clip	63
Agricultural chains according to DIN 8189	45
Alignment of the sprockets	107
ASA roller chains, ISO 606	13-15, 22,35
ATC chains	64-67
Attachment chains	48-57
Automatic chain tensioners	102ff

B

Bearing area	10ff
Bent attachments	48,50-54
BIATHLON	24,25
BIATHLON KS	26,27
Breaking load	10ff
Bush chains	
Construction and applications	113
Conveyor chains with bushings	76
Dimensions according to DIN 8164	47

C

Calculation of chain drives	126
Calculation of chain length L (in metres)	126
Calculation of chain lengths	123-126
Calculation of chain length X (in links)	123
Calculation of shaft distance a	124
Calculation of sprocket diameters	95
Calculation of sprockets	95
Centre to centre distance A for sprockets	94
Chain breaker	77
Chain cleaning	129
Chain couplings	92
Chain disassembly	130
Chain drive configurations with jockey sprockets	128
Chain drives	
Calculation (examples)	126
Configurations	127,128
Chain lengths	
Calculation	123
Chain lubricant WKS-Spezial and WKS-Plus	111
Chain maintenance	129
Chain parts	10ff
Chain puller	77
Chain repair	129,130
Chain selection (example)	126
Chain separation	130
Chain tensioning	127
Combination attachment chains	57
Connecting link No. 11, 111	10ff
Connecting links	10ff
Connecting link with cottered pin No. 111 or 12	10ff
Construction	112,113
Construction of chain drives	127,128
Construction of steel link chains	112,113
Contact angle	127
Conveyor chains	76
Cranked link chains, roller chains with cranked links	76

D

Determination of chain length L (graphically)	125
Diagram power PC	120-122
Diameters of sprockets	95
Details for	
Construction of chain drives	127,128
Enquiries and orders	131,132
Different types of steel link chains	112,113
Dimensions of chains	10ff
Dimensions of standard sprockets	78

Double cranked link No. 15	10ff
Duplex roller chains	11,14,17,19,22,25,27,29,31,34-36,38,39,41,43
Double pitch roller chains according to DIN 8181 and stainless steel	46
MARATHON double pitch roller chains	37
with bent attachments	54
with single hole straight attachments and extended pins	55
Drip lubrication	110
Drum drives	128
Dry running	109
Duplex roller chains	11,14,17,19,22,25,27,29,31,34-36,38,39,41,43

E

End links	
for leaf chains	70
Enquiries about sprockets, details	106
Efficiency	109
ETP shaft bushing	100,101
Extended pins	49,51,55,56
Extending of chains	130

F

Factor for the number of teeth n	
Calculation	95
Table	96
Factors for chain calculation	115-119
Factors for impact coefficient f_y	118
Faulty mounting of chain drives	107
Favourable lubrication	109
Formulas, designations and units	115

G

Galle chains	
According to DIN 8151	76
Construction and applications	112
Groove sizes	93

H

Hardening of sprockets	93
Hollow pin chains	23
Hub dimensions (standard sprockets)	78ff

I

Induction hardening of sprockets	93
Inner link No. 4	10ff
Inner width b_1	10ff
Inside thread	52,53
Inverted tooth (silent) chains	73
Inverted tooth (silent) chains type series HD	74
Inverted tooth (silent) chains type series HP	75
Inverted tooth chains with bushings	72

K

Keyways, sizes	93
----------------------	----

L

Lantern gear toothing	88
Leaf chains	
Construction and applications	112
Dimensions	68-71
Link numbers	123
Lubrication	108-111

M

Main chain dimensions	112,113
Maintenance-free chains MARATHON, stainless steel	40,41
Maintenance-free chains MARATHON	32-39
Maintenance-free chains TRIATHLON HT	28,29
Maintenance-free chains TRIATHLON KS	30,31
Maintenance	129
Maintenance of chain drives	129
Manual lubrication	109,110
MARATHON, maintenance-free, stainless steel	33,40
MARATHON, maintenance-free	32-39

Matched chains.....	131, 132
Mounting of chain drives.....	107
Multiplex roller chains	
Dimensions according to ISO 606 European type	
and American type.....	11,12,14,15,17,19,22,25,27,29,31,34-36,38,39,41,43,44
N	
Nominal power P.....	120-122
Number of teeth.....	78ff
O	
Oil bath.....	110
Oils.....	108-111
Operating factors k.....	115
Orders, details.....	131
Orders of special chains, details.....	132
Outer diameter of sprockets.....	95
Outer link No. 7 (to be riveted).....	10ff
P	
PCD	
Calculation.....	95
for roller chain sprockets.....	97-99
Pitch angle.....	95
Pitch p.....	10ff
Plastic rollers.....	23,38,39,60,61
Plate end links	
for leaf chains.....	70
POM-Clips.....	18,19
POM-Clips POM clips with top surface TPU.....	20,21
Power chains.....	22
Power diagrams.....	120-122
Pre-selection of leaf chains.....	116,117
Pre-selection of roller chain drives.....	118ff
Pre-stretched chains.....	131,132
Pressure circulation lubrication.....	109,110
Profile of sprockets.....	95
Pull strand.....	127
Pusher dog.....	58
R	
Recommended lubrication and lubricants.....	108-111
Replacing of chain links.....	129,130
Required space for standard sprockets.....	78ff
Return strand.....	127
Roller chains	
Construction.....	112,113
Dimensions according to ISO 606 and works-standards.....	10ff
Heavy duty design.....	22
Power chains.....	22
Type series GL.....	17-22,25,27,29,31,36,41-45
with bent attachments.....	48,50-54
with extended pins.....	49,51,55,56
with single hole straight attachments.....	49-53,55
Roller conveyors with chains.....	128
Roller diameter d1.....	10ff
Root circle diameter, calculation and checking.....	95
S	
Safety factors for leaf chains.....	116,117
Shaft bushings.....	100,101
Shaft centre distance, shaft distance.....	124
Shaft distance	
Calculation.....	124
Guidelines.....	127-129
Shortening and extending of roller chains.....	130
Side bow chains.....	16
Simplex roller chains	
Construction and applications.....	112,113
Dimensions according to ISO 606 and works-standard specifications.....	
.....	10,13,16,17,19,21,22,25,27,29,31,34-36,38,39,41,42,45,46,48ff
Type series RF made of stainless and acid-resistant steel..	40-44,50,51,53,54,55,59-61
Single cranked link No. 12.....	10ff
Slack span.....	127
Sonderausführungen von Kettenrädern.....	87,88
SPANN-BOX®.....	102-105
SPANN-BOY®.....	102-105
Special heavy duty chains.....	22
Speed range of roller chains.....	119-122
Speeds	
Bush chains.....	47
for roller chains refer to "Speeds and chain pitches".....	119
also refer to "Lubrication".....	109
Speeds and chain pitches.....	119
Splash lubrication (oil bath method).....	110
Spring clip connecting link (connecting link No. 11).....	10ff
Sprocket designs.....	93
Sprocket diameters (table)	
for roller chains.....	97-99
Sprockets	
Axial profiles.....	94
Calculation.....	95
Design "A" (plate sprockets).....	89-91
Design "B" (with hub on one side).....	78-88
Designs and steel grades.....	93
Tooth design.....	95
Stainless steel chains.....	41-44,46,50,51,54,55,60-62
Stainless steel chains RF.....	40-44,50,51,53,54,55,59-61
Standard sprockets.....	78ff
Straight attachments.....	49-55
T	
Tables for chain dimensions.....	10ff
Tip circle diameter	
Calculation.....	95
Table.....	97-99
To be riveted, outer link No. 7.....	10ff
Tooth designs.....	95
Toothing, hardened.....	93
Toothing.....	95
Toothing check.....	95
Top-plate conveyor chains.....	59
Transverse pitch e.....	11,12,14,15,17,22,25,27,29,31,34-36,38,39,41,43,44,57,60-61
Triplex roller chains.....	12,15,17,22,25,27,29,31,34-36,38,41,44
V	
Validity of power diagrams.....	120-122
W	
Wear life.....	118,120-122

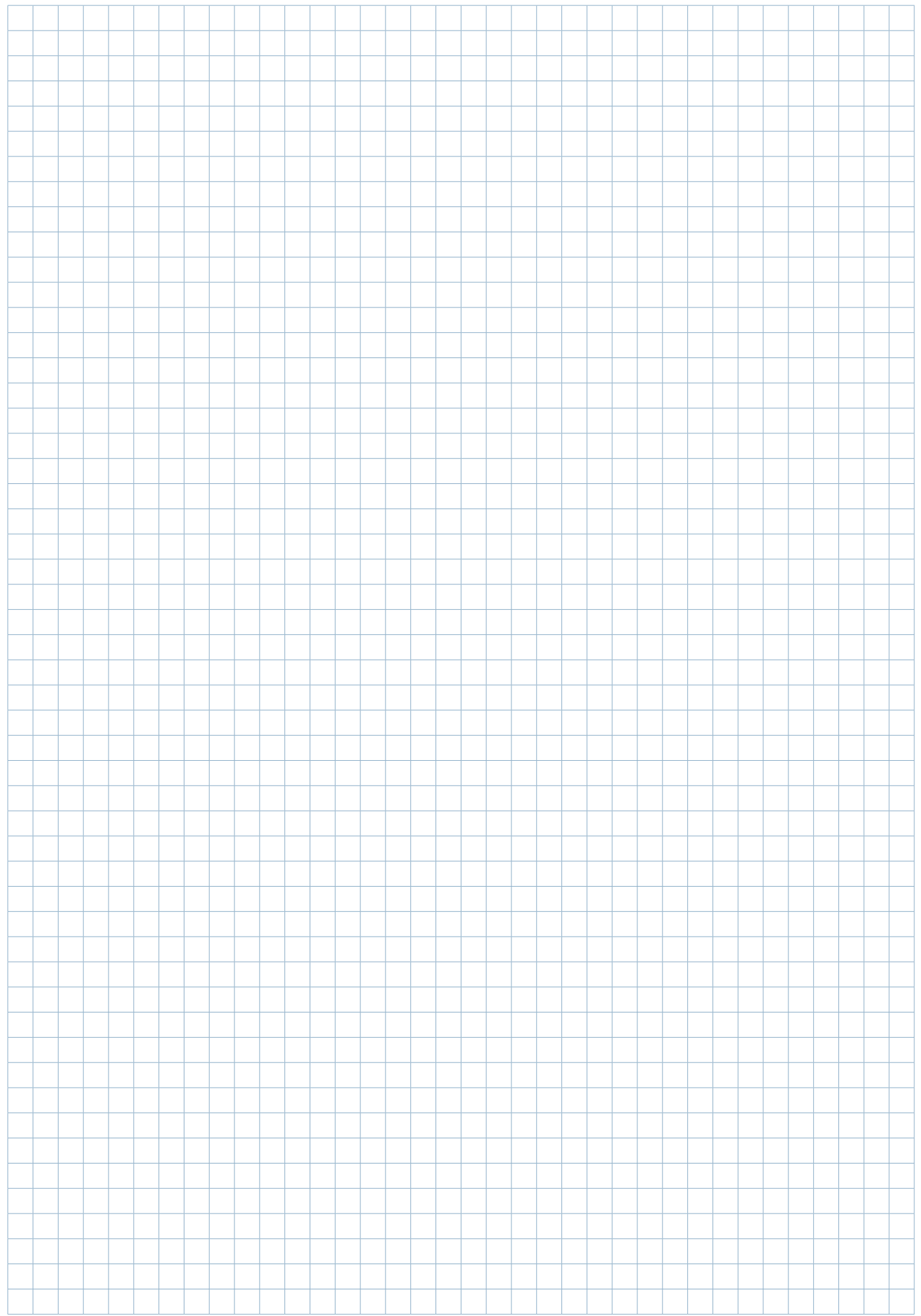

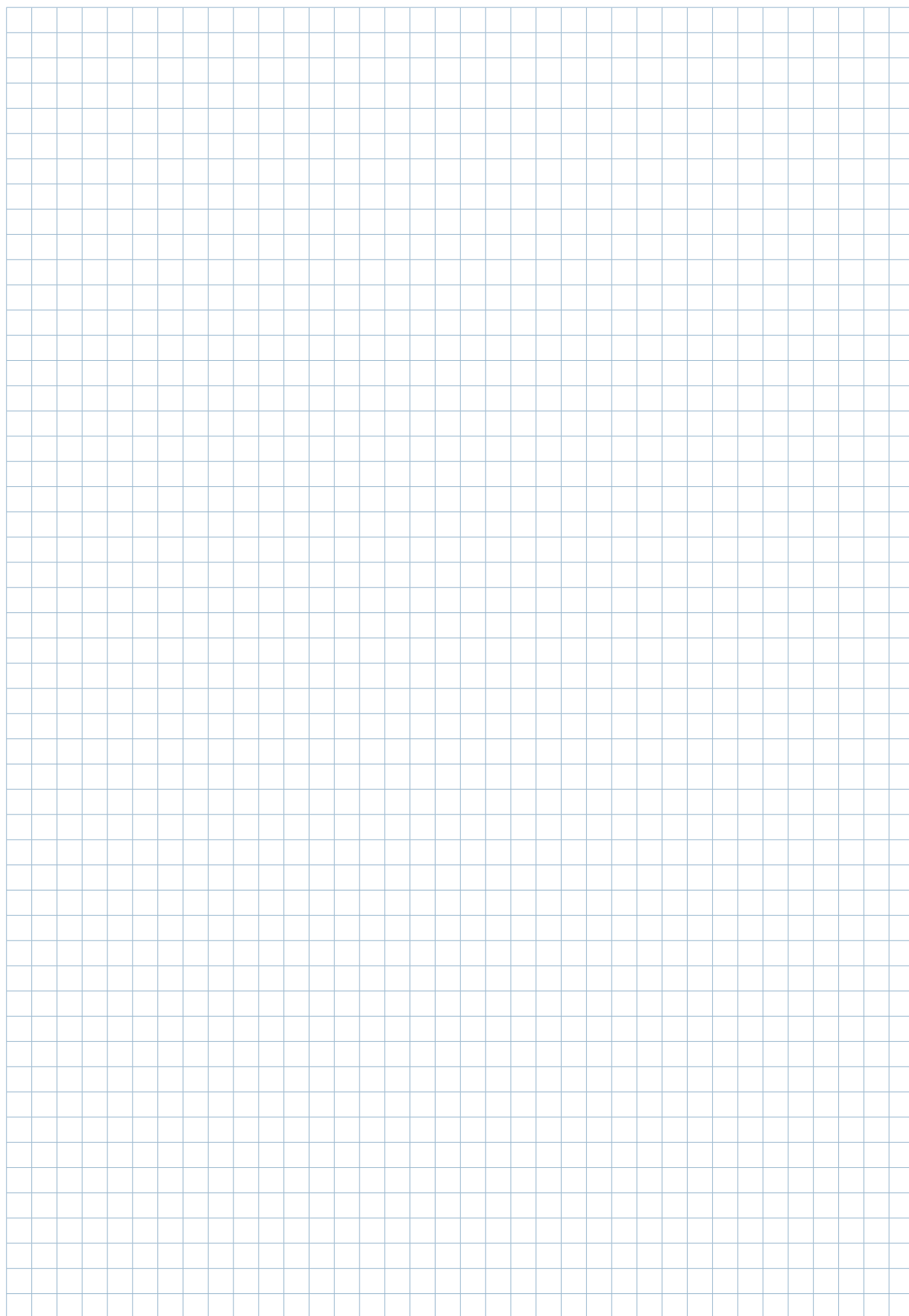

WIPPERMANN jr. GmbH
Delsterner Straße 133
58091 Hagen
Postfach 4020
58040 Hagen
Germany

Phone +49 23317820
Fax +49 2331782356
E-mail info@wippermann.com
Internet www.wippermann.com